

MTR, MTRE, SPK, MTH, MTA

Immersible pumps

50/60 Hz



1. Introduction	3	Shaft seals for SPK	43
MTR, SPK and MTH	3	Shaft seals for MTH	43
MTA	3		
When to select an E-pump	3		
MTRE pumps with built-in frequency converter	4		
ErP compliant	4		
Minimum efficiency index	4		
2. Applications	5		
Machine tool applications	5		
Machine tool sub applications	5		
3. Performance range	6		
MTR, 50 Hz	6		
MTRE, 50 Hz	7		
MTR, 60 Hz	8		
MTRE, 60 Hz	9		
MTRE high pressure, 50/60 Hz	9		
SPK, 50 Hz	10		
SPK, 60 Hz	10		
MTH, 50 Hz	11		
MTH, 60 Hz	11		
MTA, 50 Hz	12		
MTA, 60 Hz	12		
MTA-H, 50 Hz	13		
MTA-H, 60 Hz	13		
4. Product range	14		
MTR, MTRE	14		
SPK	16		
MTH	17		
MTA	18		
5. Motors	19		
Motors for MTR and SPK pumps	19		
Motors for MTH pumps	20		
Motors for MTA pumps	20		
Terminal box positions	20		
Frequency of starts and stops	20		
Sound pressure level	21		
Optional motors	21		
Motors for MTRE pumps	21		
6. Control of MTRE pumps	26		
Control options	26		
Control modes for MTRE pumps	28		
7. Construction	29		
Construction of MTR pumps	29		
Construction of SPK pumps	35		
Construction of MTH pumps	39		
Construction of MTA pumps	41		
8. Shaft seals	43		
Shaft seals for MTR, MTRE	43		
Shaft seals for MTRE HS	43		
9. Identification	44		
Type keys for MTR, SPK, MTH	44		
Type key for MTA	45		
10. Installation	46		
Installation of MTR, MTRE pumps	46		
Installation of SPK pumps	47		
Installation of MTH pumps	47		
Installation of MTA pumps	48		
11. Selection and sizing	50		
Selection of pumps	50		
Pumped liquids	54		
List of pumped liquids	55		
12. Performance curves and technical data	57		
Introduction to performance curves	57		
MTR, MTRE, 50 Hz	59		
MTR, MTRE, 60 Hz	92		
MTRE for high-pressure applications	124		
SPK, 50 Hz	130		
SPK, 60 Hz	136		
MTH, 50 Hz	142		
MTH, 60 Hz	157		
MTA, 50/60 Hz	170		
13. Motor data	188		
Standard motors, MTR and SPK	188		
Motors, MTH, 50 Hz	191		
Motors, MTH, 60 Hz	191		
Motors, MTH, 50 Hz, 3 x 200 V	192		
Motors, MTH, 50/60 Hz, 3 x 200 V	192		
E-motors, MTRE	193		
14. Accessories	194		
Pipe connection	194		
Counterflanges for MTR, MTRE, SPK	194		
Sensors	195		
EMC filter	197		
Remote controls	197		
CIM communication interface modules	198		
15. Variants	199		
List of variants, on request	199		
Immersion depths, MTR, MTRE	200		
Immersion depths, SPK	202		
Horizontal mounting	204		
120 °C solution	204		
Inlet pipe	204		
16. Grundfos Product Center	205		

1. Introduction

MTR, SPK and MTH



TM082004

MTR, SPK and MTH pumps

MTR, SPK and MTH pumps are vertical multistage centrifugal pumps designed for pumping of cooling lubricants for machine tools, condensate transfer and similar applications.

The pumps are designed to be mounted on top of tanks with the chamber stack immersed in the pumped liquid.

The pumps come in various sizes and have various numbers of stages to provide the flow rate, the pressure and the installation length required. To meet specific depths of tanks or containers, the immersed length of the pump can be varied using empty chambers.

The pumps consist of two main components: The motor and the pump unit.

The motor is a Grundfos standard MG motor designed to EN standards.

The pump unit consists of optimised hydraulics, various types of connections, a motor stool, a given number of chambers and various other parts.

The pumps are available in two material versions:

- standard range (A-version) with wetted parts of cast iron and stainless steel
- stainless steel version (I-version) with all wetted parts of stainless steel EN/DIN 1.4301 or better.

The mounting flange dimensions are according to EN/DIN 12157. The mechanical shaft seal is according to EN/DIN 12756.

MTA



TM051132

MTA

The MTA range of single-stage immersible pumps has been designed especially for filtering systems in the machine tool industry.

The MTA pumps efficiently transport liquid containing chips, fibres and abrasive particles to the filtering unit. The semi-open impellers allow the passing of chips up to 10 mm.

These low-pressure pumps are available in 9 different hydraulic variants and come with a choice between top inlet or bottom inlet.

The pumps are designed to be mounted on top of tanks with the pump part immersed into the pumped liquid.

The pumps are designed to be maintenance-free, and therefore do not contain shaft seals or other wear parts.

When to select an E-pump

Select an E-pump if the following is required:

- controlled operation, that is the consumption fluctuates
- constant pressure
- communication with the pump.

Adaptation of performance through frequency-controlled speed control offers obvious benefits, such as the following:

- energy savings
- increased comfort
- control and monitoring of the pump performance.

MTRE pumps with built-in frequency converter



TM0820051

MTRE pumps

MTRE pumps are MTR pumps with an E-motor, that is a motor with built-in frequency control. Frequency control enables continuously variable control of motor speed, making it possible to set the pump to operate in any duty point. The motors of the MTRE pumps are Grundfos MGE motors designed to EN standards.

MTRE pumps are ideal for machining centres which operate with different machining processes and tools, as this will often result in different needs for flow and pressure.

The following features and benefits are typical for choosing an MTRE pump:

- energy savings
- low heat input into the cooling lubricant
- increased cooling efficiency
- better performance of the machining centre
- simple integration with the machining centre.

ErP compliant

The product is energy-optimized and complies with the ecodesign requirements for water pumps specified in the ErP Directive (Commission Regulation (EC) No 547/2012), which became effective on 1 January 2013. As from this date, all pumps are classified and graduated in the Minimum Efficiency Index (MEI).

Minimum efficiency index

Minimum efficiency index (MEI) means the dimensionless scale unit for hydraulic pump efficiency at best efficiency point (BEP), part load (PL) and overload (OL). The Commission Regulation (EU) sets efficiency requirements to $MEI \geq 0.10$ as from 1 January 2013 and $MEI \geq 0.40$ as from 1 January 2015. An indicative benchmark for best-performing water pump available on the market as from 1 January 2013 is determined in the Commission Regulation.

- The benchmark for most efficient water pumps is $MEI \geq 0.70$.
- The efficiency of a pump with a trimmed impeller is usually lower than that of a pump with the full impeller diameter. The trimming of the impeller will adapt the pump to a fixed duty point, leading to reduced energy consumption. The minimum efficiency index (MEI) is based on the full impeller diameter.
- The operation of this water pump with variable duty points may be more efficient and economic when controlled, for example, by the use of a variable-speed drive that matches the pump duty to the system.
- Information on benchmark efficiency is available at <http://europump.eu/efficiencycharts>.

Minimum efficiency index (MEI)

Pump type	MEI
MTR 1s-3/3	0.67
MTR 1-3/3	> 0.70
MTR 3-3/3	> 0.70
MTR 5-3/3	0.57
MTR 8-3/3	> 0.70
MTR 10-3/3	> 0.70
MTR 15-3/3	> 0.70
MTR 20-3/3	> 0.70
MTR 323/3	> 0.70
MTR 45-3/3	> 0.70
MTR 64-3/3	> 0.70
MTH 2-3/3	> 0.70
MTH 4-3/3	> 0.70
MTH 8-3/3	> 0.64
MTH 10-3/3	> 0.59
MTH 15-3/3	> 0.59

2. Applications

Application	MTR(E)	SPK	MTH	MTA
Boring	•	•	•	•
Sawing	-	-	-	•
Milling	•	•	•	•
Grinding	•	•	•	•
Spark erosion	•	•	•	-
Wire cutting	•	•	•	-
Turning	•	•	•	•
Chilling	•	•	•	•
Part washing	•	•	•	-
Filtration	-	•	•	•
Condensate systems	•	•	•	-
Wash and clean	•	•	•	-

- The pump is suitable for this application.

Machine tool applications

The Grundfos range of high-pressure pumps offers unsurpassed accuracy and stability to make sure that nothing interferes with the delicate machining process. Equally important, high efficiency ensures a remarkably low heat input into the cooling lubricant. Integrated frequency converters can be optionally supplied for increased system efficiency and flexibility. Suitable for machine tool applications are the immersible MTR, SPK, MTH, MTA and MTS, offering a tank-mounted design. For MTS data, see the separate MTS data booklet.

Machine tool sub applications

Boring

Grundfos is capable of providing the exact pressure and flow rate required for different materials, bore diameters and tool speeds in both through boring and blind boring. Our flexible range includes pumps supplying a pressure of up to 130 bar (MTS pumps), required for the deep blind-hole boring.

Milling and turning

The Grundfos range easily meets the individual cooling requirements of different materials in milling and turning, from low flow rate and low pressure to high flow rate and high pressure. The pumps are available in different lengths and customized to fit specific tank sizes. In fact, the modular pump construction allows for more than 1,000,000 individual configurable variants.

Wire cutting

In wire cutting it is essential that the liquids are clean. This results in a more accurate process and extends the life of the filter. As a steady temperature is required for wire cutting operation, the process will benefit from a Grundfos E-solution.

Filtration

Reliable filtration is crucial in top-quality machine tool applications, as it prolongs the life of the tool and prevents chips from damaging surfaces or tolerances.

With semi-open impellers, MTA and MTB are ideal for transporting liquids containing chips, fibres and abrasive particles to the filtration system.

For MTB data, see the separate MTB data booklet.

Part washing

The Grundfos range includes pumps suitable for corrosive liquids and liquids with a high content of particles. Our frequency-converter-operated pumps with high-efficiency motors ensure that systems operate under the best possible conditions with low-energy consumption. MTB and all immersible pumps are suitable for this application.

Chilling

The reliable and thoroughly-tested pump range for chillers offers a particularly diverse application spectrum. It covers cooling-water circuits, washing plants, industrial circulation systems and general pressure boosting applications. All pumps are available with an E-motor to increase efficiency and perfectly control any process. All immersible pumps are suitable for this application.

Condensate systems

As condensate is normally pumped from a tank, an immersible pump will be a perfect choice. It is a compact solution as half the pump will be in the tank. It has an optimum suction as no pipes or valves are needed in front of the inlet. For temperatures above 90 °C, a 120 °C version is available.

Wash and clean

As for condensate systems, wash and clean applications are typically based around a tank. The immersible pumps can save space and secure an optimum suction. An A-version in all stainless steel is available for aggressive liquids.

3. Performance range

MTR, 50 Hz

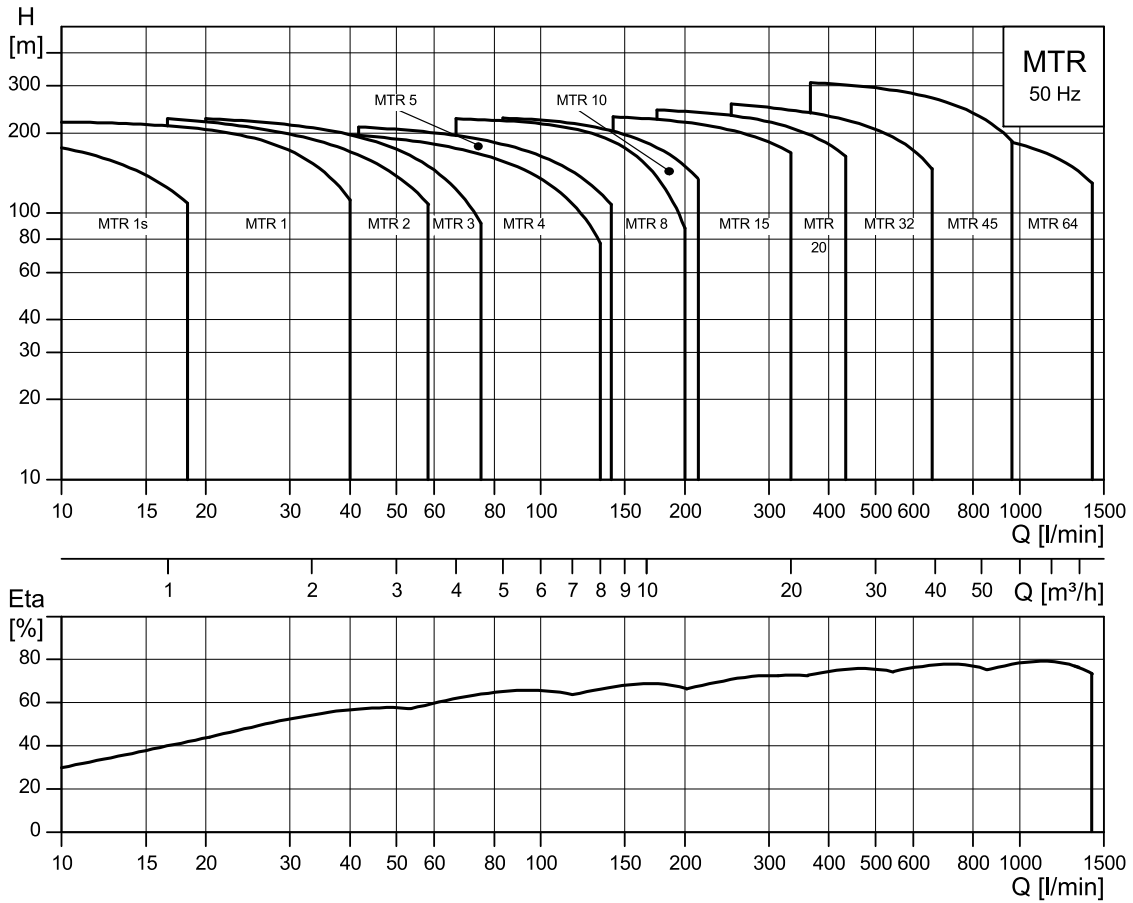

For individual performance curves for MTR 2 and 4 pumps, see Grundfos Product Center at www.grundfos.com.

TM027818

MTRE, 50 Hz

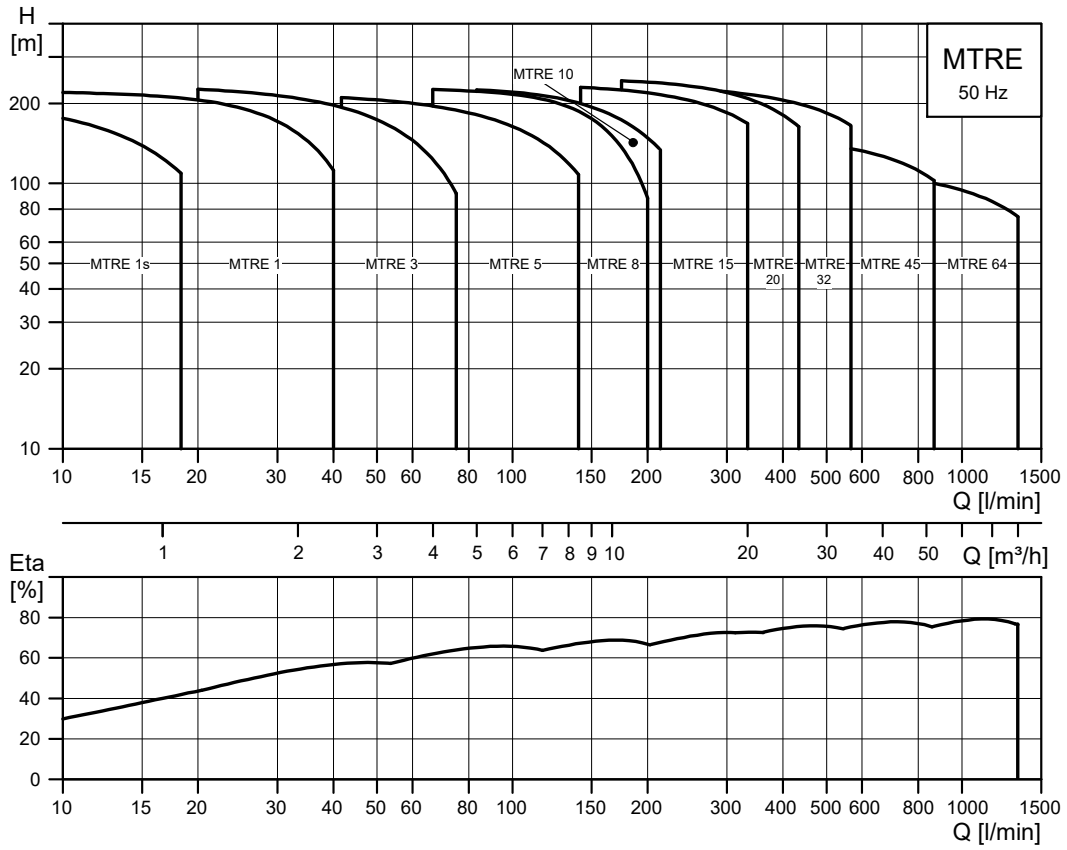

TM028553

MTR, 60 Hz

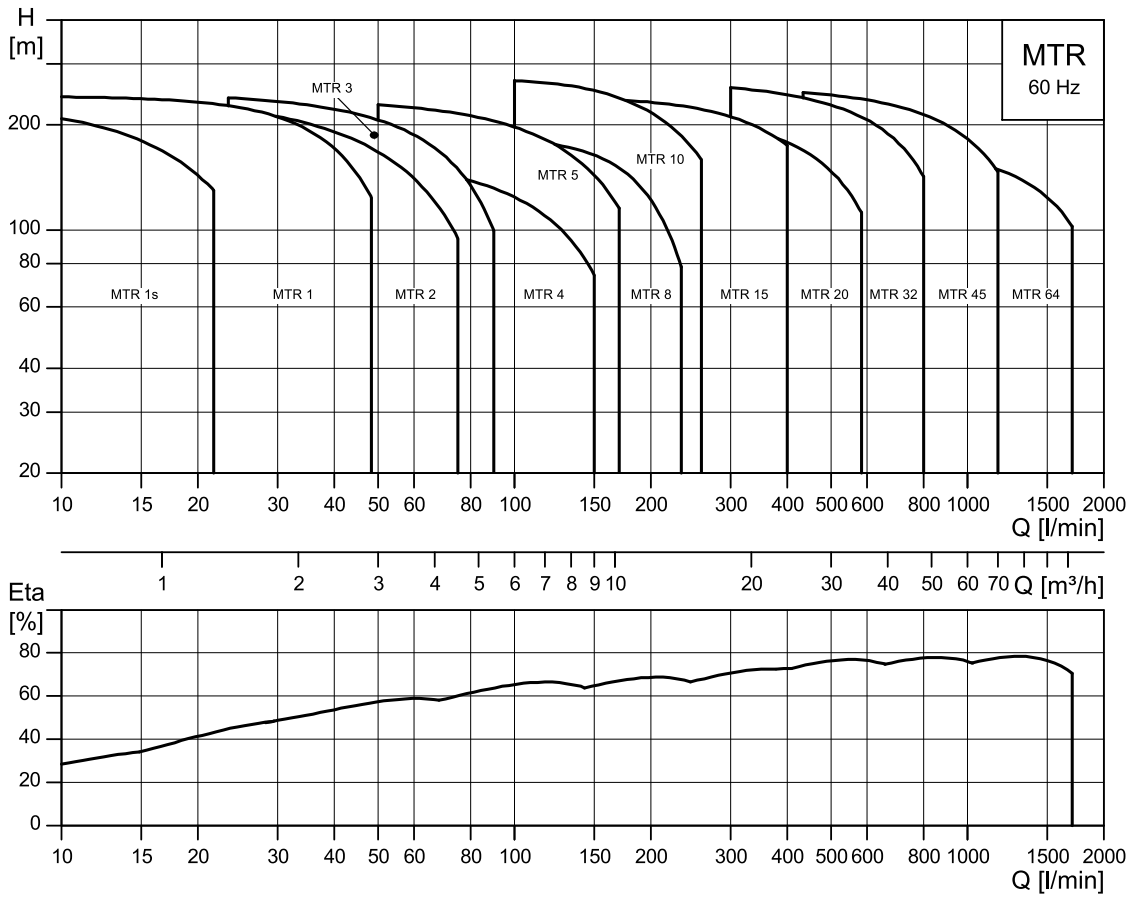

For individual performance curves for MTR 2 and 4 pumps, see Grundfos Product Center at www.grundfos.com.

TM028105

MTRE, 60 Hz

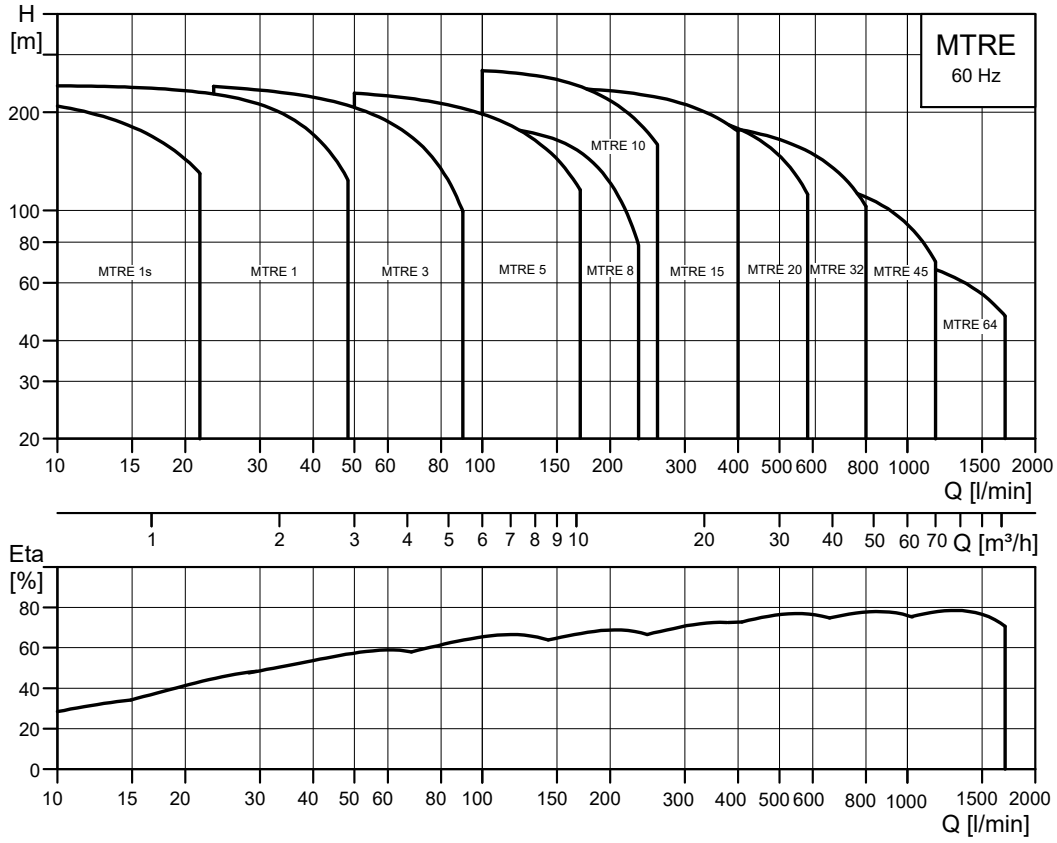

TM028554

MTRE high pressure, 50/60 Hz

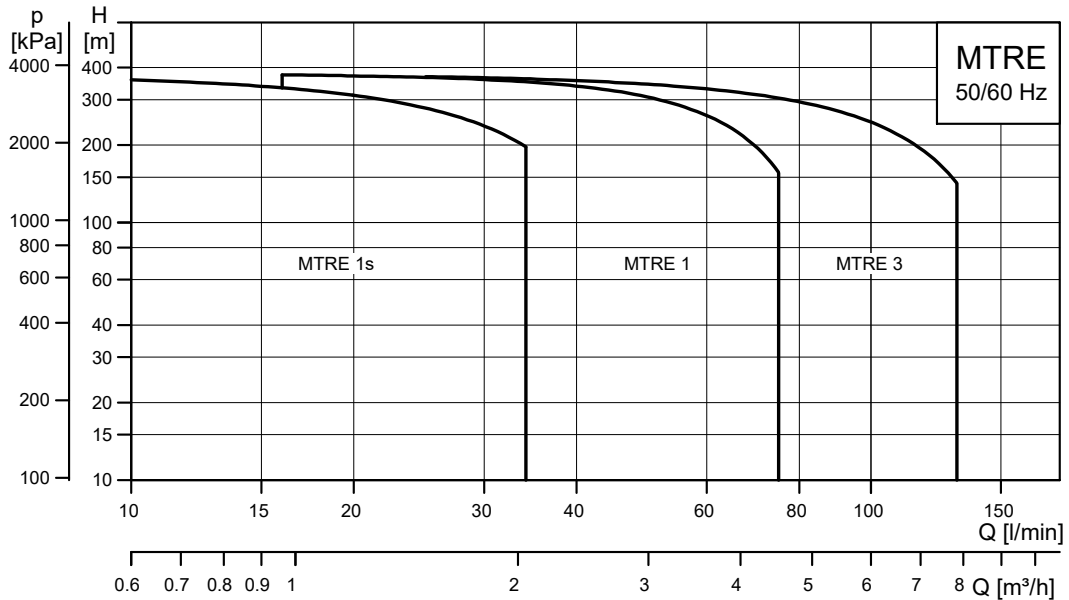

TM051565

SPK, 50 Hz

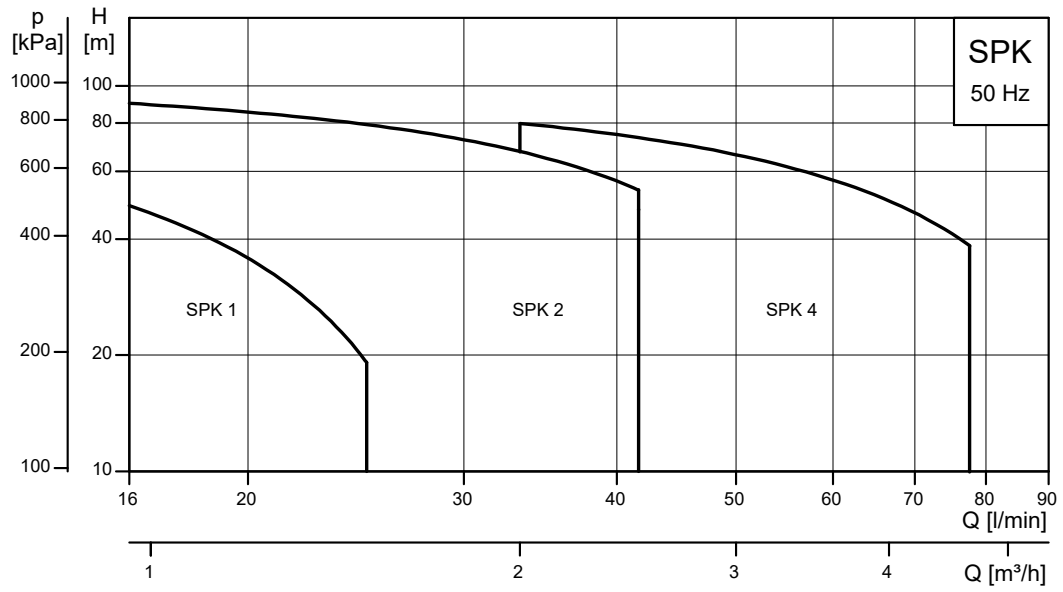

TM008398

SPK, 60 Hz

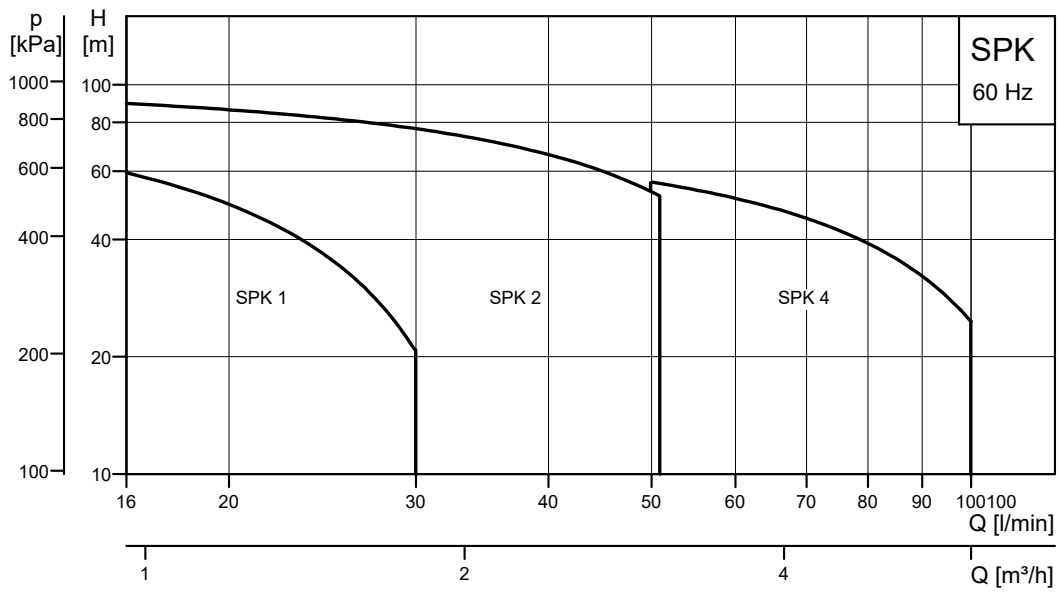

TM008397

MTH, 50 Hz

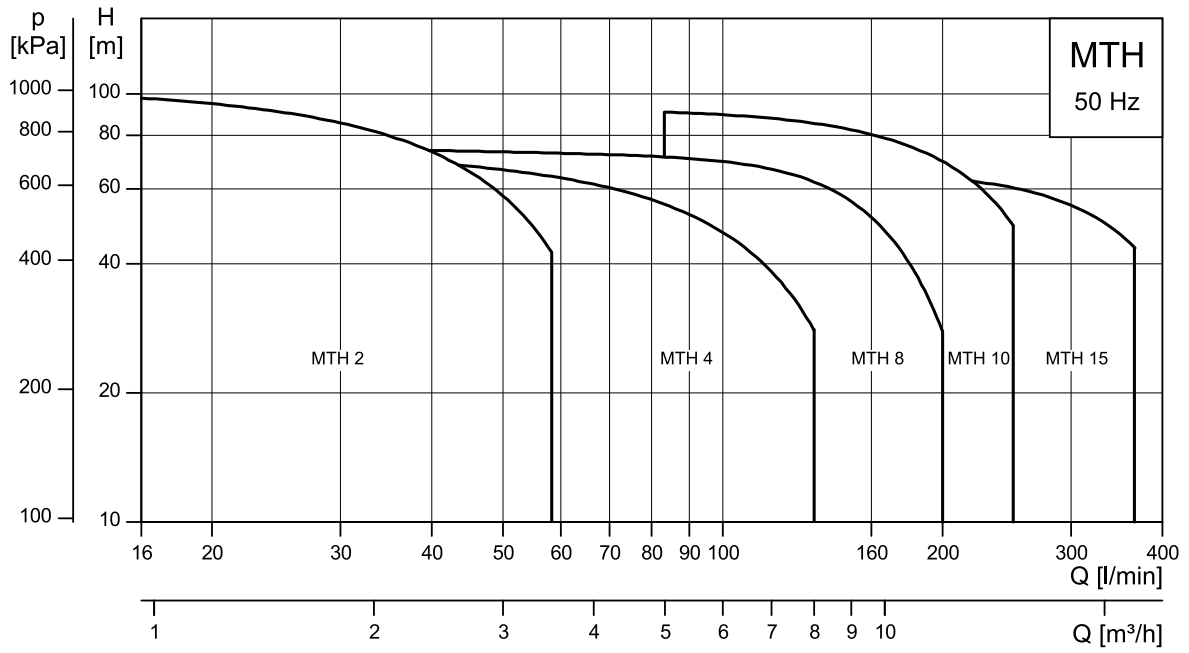

TM027828

MTH, 60 Hz

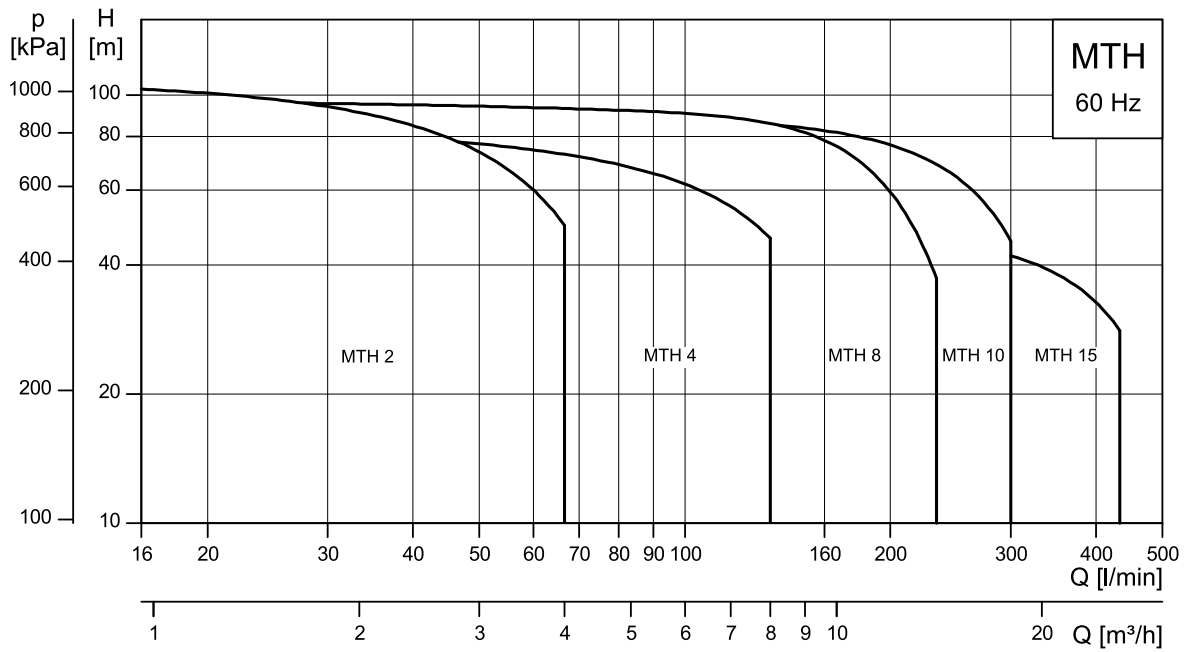

TM027829

MTA, 50 Hz

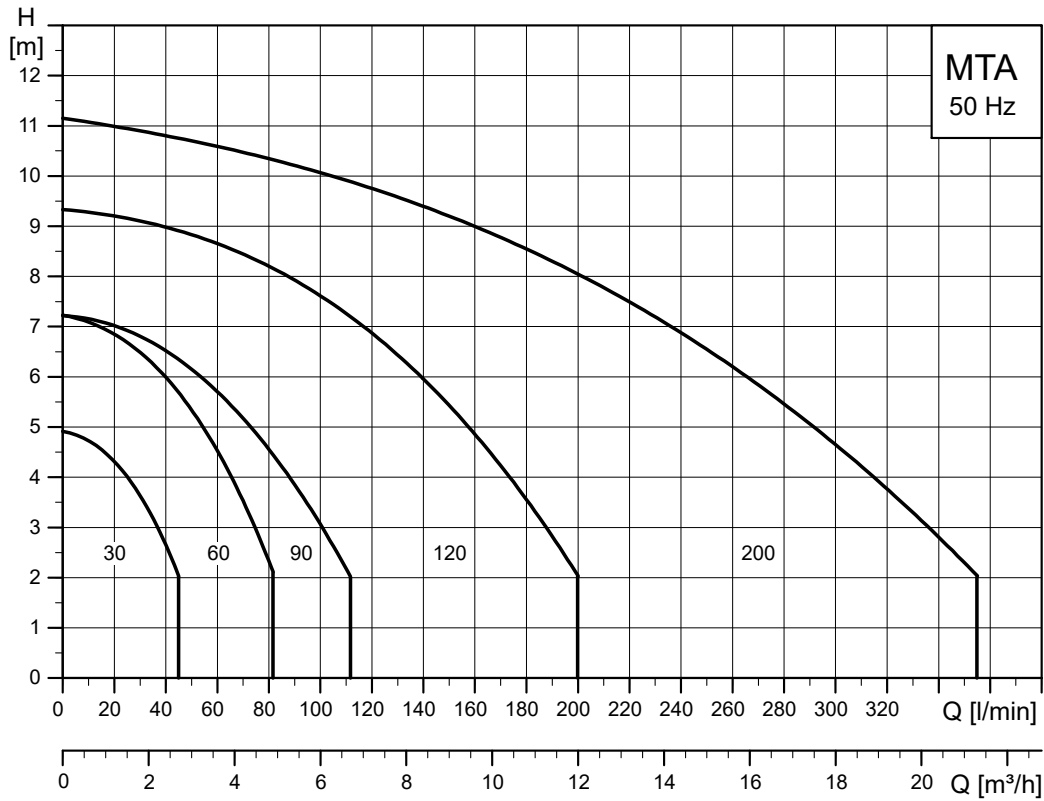

TM049437

MTA, 60 Hz

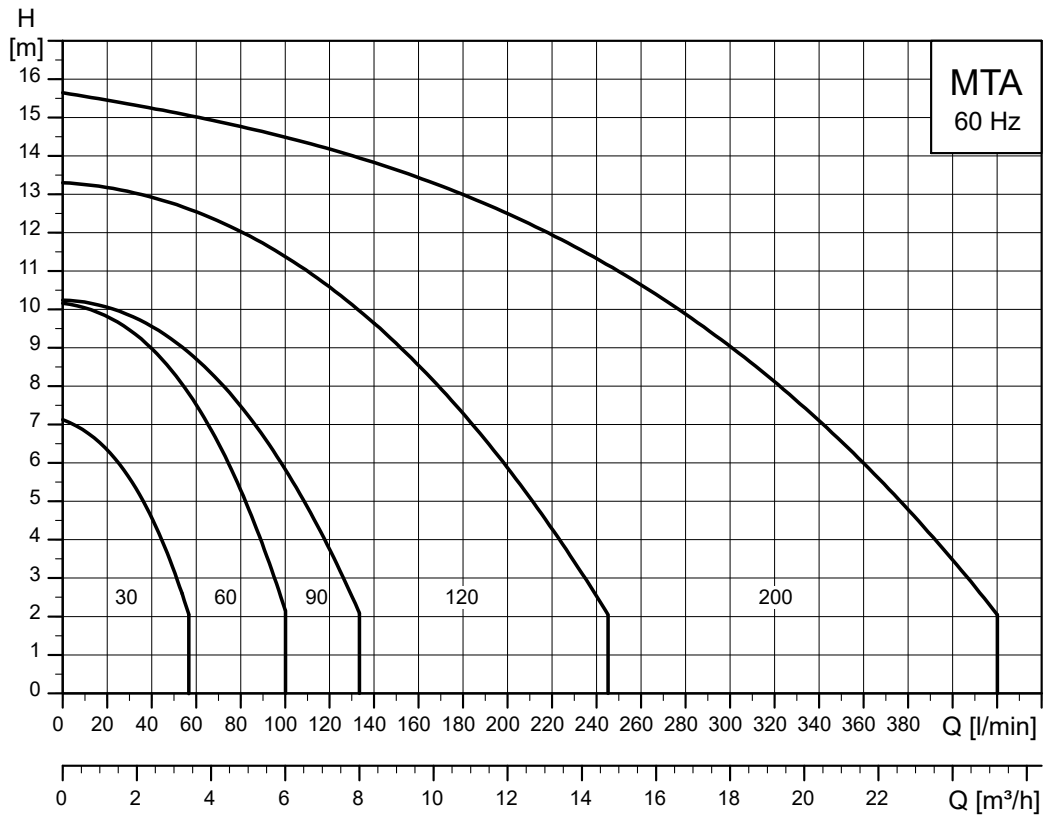

TM049439

MTA-H, 50 Hz

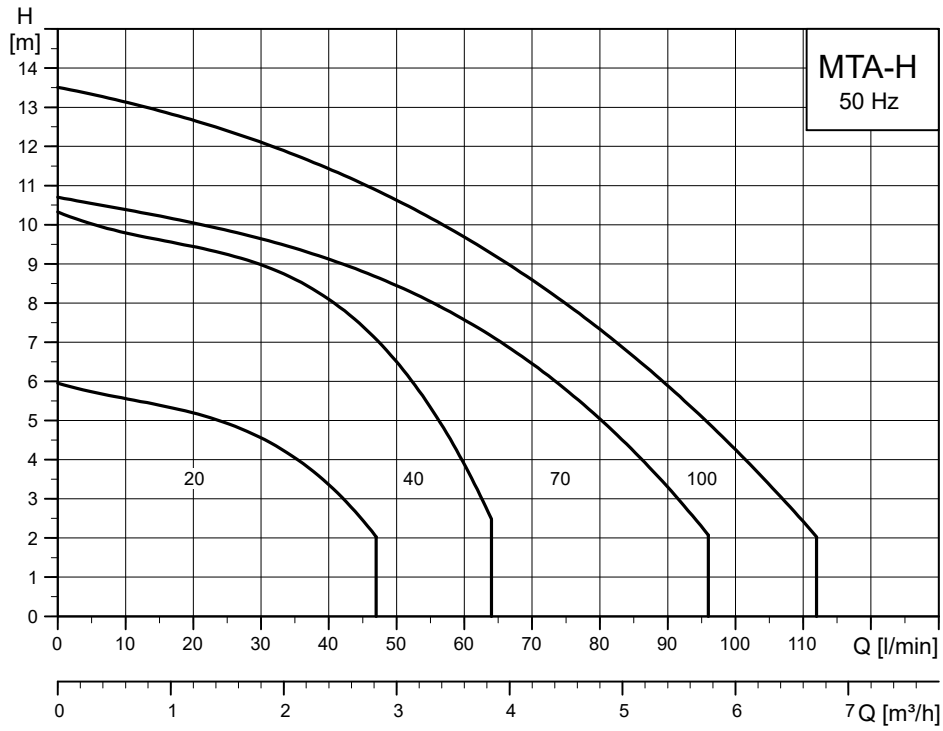

TM049438

MTA-H, 60 Hz

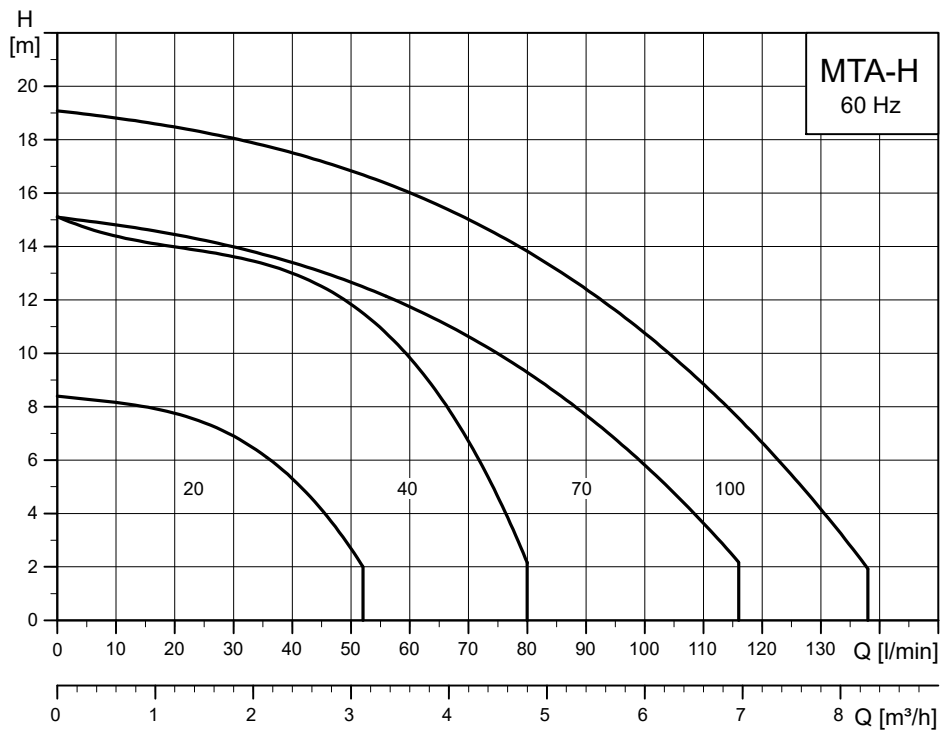

TM049440

4. Product range

MTR, MTRE

50 Hz

Pump	MTR, MTRE 1s	MTR, MTRE 1	MTR, MTRE 3	MTR, MTRE 5	MTR, MTRE 8	MTR, MTRE 10	MTR, MTRE 15	MTR, MTRE 20	MTR, MTRE 32	MTR, MTRE 45	MTR, MTRE 64
Rated flow rate [m ³ /h]	0.8	1	3	5	8	10	15	20	32	45	64
Rated flow rate [l/min]	13	17	50	83	133	167	250	333	533	750	1067
Temperature range [°C]	-10 to +90										
Maximum efficiency [%]	35	48	58	66	62	70	72	72	76	78	80
MTR pumps											
Flow range [m ³ /h]	0.3 - 1.3	0.7 - 2.4	1.2 - 4.5	2.5 - 8.5	4-12	5-13	8.5 - 23.5	10.5 - 29	15-40	22-58	30-85
Flow range [l/min]	5-22	12-40	20-75	42-142	67-200	83-217	142-392	175-483	250-667	367-967	500-1417
Maximum head [bar]	20	22	23	21	25	22	23	24	27	32	22
Motor power[kW]	0.37 - 1.1	0.37 - 2.2	0.37 - 3.0	0.37 - 5.5	0.37 - 7.5	0.37 - 7.5	1.1 - 15.0	1.1 - 18.5	1.5 - 30	3.0 - 45	4.0 - 45
MTRE pumps											
Flow range [m ³ /h]	0.3 - 1.3	0.7 - 2.4	1.2 - 4.5	2.5 - 8.5	4-12	5-13	8.5 - 23.5	10.5 - 29	15-40	22-58	30-85
Flow range [l/min]	5-22	12-40	20-75	42-142	67-200	83-217	142-392	175-483	250-667	367-967	500-1417
Maximum head [bar]	20	22	23	21	25	22	23	24	22	15	11
Motor power[kW]	0.37 - 1.1	0.37 - 2.2	0.37 - 3.0	0.37 - 5.5	0.37 - 7.5	0.37 - 7.5	1.1 - 15.0	1.1 - 18.5	1.5 - 22	3.0 - 22	4.0 - 22

60 Hz

Pump	MTR, MTRE 1s	MTR, MTRE 1	MTR, MTRE 3	MTR, MTRE 5	MTR, MTRE 8	MTR, MTRE 10	MTR, MTRE 15	MTR, MTRE 20	MTR, MTRE 32	MTR, MTRE 45	MTR, MTRE 64
Rated flow rate [m ³ /h]	1	1.2	3.6	6	10	12	18	24	38	54	77
Rated flow rate [l/min]	17	20	60	100	167	200	300	400	633	900	1283
Temperature range [°C]	-10 to +90										
Maximum efficiency [%]	35	49	59	67	61	70	72	72	76	78	79
MTR pumps											
Flow range [m ³ /h]	0.4 - 1.6	0.8 - 2.9	1.4 - 5.4	3-10	4.5 - 14	6 - 15.5	10 - 28.5	13-35	18-48	26-70	36-102
Flow range [l/min]	7-27	13-23	48-90	50-167	75-233	100-258	167-475	217-583	300-800	433-1167	600-1700
Maximum head [bar]	22	24	23	23	19	26	23	21	27	26	18
Motor power[kW]	0.37 - 1.5	0.37 - 2.2	0.37 - 4.0	0.55 - 7.5	0.55 - 7.5	0.75 - 11	1.5 - 11	2.2 - 18.5	2.2 - 30	5.5 - 45	7.5 - 45
MTRE pumps											
Flow range [m ³ /h]	0.4 - 1.6	0.8 - 2.9	1.4 - 5.4	3-10	4.5 - 14	6 - 15.5	10 - 28.5	13-35	18-48	26-70	36-102
Flow range [l/min]	7-27	13-23	48-90	50-167	75-233	100-258	167-475	217-583	300-800	433-1167	600-1700
Maximum head [bar]	22	24	23	23	19	26	23	21	18	13	9
Motor power[kW]	0.37 - 1.5	0.37 - 2.2	0.37 - 4.0	0.55 - 7.5	0.55 - 7.5	0.75 - 11.0	1.5 - 11.0	2.2 - 11.0	2.2 - 22	5.5 - 22	7.5 - 22

Material variants

Pump	MTR, MTRE 1s	MTR, MTRE 1	MTR, MTRE 3	MTR, MTRE 5	MTR, MTRE 8	MTR, MTRE 10	MTR, MTRE 15	MTR, MTRE 20	MTR, MTRE 32	MTR, MTRE 45	MTR, MTRE 64
Pump head (A-version): cast iron, EN-GJL-200	•	•	•	•	•	•	•	•	•	•	•
Pump head (I-version): stainless steel, EN 1.4408	•	•	•	•	•	•	•	•	•	•	•

Pipe connection

Pump	MTR, MTRE 1s	MTR, MTRE 1	MTR, MTRE 3	MTR, MTRE 5	MTR, MTRE 8	MTR, MTRE 10	MTR, MTRE 15	MTR, MTRE 20	MTR, MTRE 32	MTR, MTRE 45	MTR, MTRE 64
A-version											
Internal thread	G 1 1/4	G 1 1/4	G 1 1/4	G 1 1/4	G 1 1/4	G 2	G 2	G 2	-	-	-
	-	-	-	-	-	Rp 2	Rp 2	Rp 2	-	-	-
Square flange with internal thread	Rp 1 1/4	Rp 1 1/4	Rp 1 1/4	Rp 1 1/4	Rp 1 1/4	-	-	-	-	-	-

Pump	MTR, MTRE 1s	MTR, MTRE 1	MTR, MTRE 3	MTR, MTRE 5	MTR, MTRE 8	MTR, MTRE 10	MTR, MTRE 15	MTR, MTRE 20	MTR, MTRE 32	MTR, MTRE 45	MTR, MTRE 64
Flange	-	-	-	-	-	-	-	-	DN 65	DN 80	DN 80
I-version											
Internal thread	G 1 1/4	G 1 1/4	G 1 1/4	G 1 1/4	G 1 1/4	G 2	G 2	G 2	-	-	-
	Rp 1 1/4	Rp 1 1/4	Rp 1 1/4	Rp 1 1/4	Rp 1 1/4	Rp 2	Rp 2	Rp 2	-	-	-
Flange	-	-	-	-	-	-	-	-	DN 65	DN 80	DN 80

Installation length [mm]

Pump	MTR, MTRE 1s	MTR, MTRE 1	MTR, MTRE 3	MTR, MTRE 5	MTR, MTRE 8	MTR, MTRE 10	MTR, MTRE 15	MTR, MTRE 20	MTR, MTRE 32	MTR, MTRE 45	MTR, MTRE 64
------	--------------	-------------	-------------	-------------	-------------	--------------	--------------	--------------	--------------	--------------	--------------

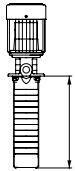

	160-1006	160-1006	160-1006	169-1006	196-1006	148-1018	178-1033	178-1033	223-1343	244-1444	249-1487
--	----------	----------	----------	----------	----------	----------	----------	----------	----------	----------	----------

Shaft seal*

Pump	MTR, MTRE 1s	MTR, MTRE 1	MTR, MTRE 3	MTR, MTRE 5	MTR, MTRE 8	MTR, MTRE 10	MTR, MTRE 15	MTR, MTRE 20	MTR, MTRE 32	MTR, MTRE 45	MTR, MTRE 64
HUUV	•	•	•	•	•	•	•	•	•	•	•

* Other shaft seals on request.

SPK**50 Hz**

Pump	SPK 1	SPK 2	SPK 4
Rated flow rate [m ³ /h]	1	2	4
Rated flow rate [l/min]	16.7	33.3	67
Flow range [m ³ /h]	0.2 - 1.5	0.5 - 2.5	2.0 - 5.0
Flow range [l/min]	3.3 - 25	8.3 - 41.7	33.3 - 83
Maximum head [bar]	8.6	10.5	9.8
Motor power [kW]	0.06 - 0.55	0.06 - 0.75	0.06 - 1.1
Liquid temperature range [°C]	-10 to +90	-10 to +90	-10 to +90
Maximum efficiency [%]	40	55	50

60 Hz

Pump	SPK 1	SPK 2	SPK 4
Rated flow rate [m ³ /h]	1	2	4
Rated flow rate [l/min]	16.7	33.3	67
Flow range [m ³ /h]	0.2 - 1.8	0.6 - 3.0	2.0 - 6.0
Flow range [l/min]	3.3 - 30	10.0 - 50	33.3 - 100
Maximum head [bar]	8.5	10.0	7.5
Motor power [kW]	0.06 - 0.55	0.06 - 1.1	0.12 - 1.1
Liquid temperature range [°C]	-10 to +90	-10 to +90	-10 to +90
Maximum efficiency [%]	40	55	50

Material variants

Pump	SPK 1	SPK 2	SPK 4
Pump head (A-version): cast iron, EN-GJL-200	•	•	•
Pump head (I-version): stainless steel, EN 1.4408	•	•	•

Pipe connection

Pump	SPK 1	SPK 2	SPK 4
A-version			
Internal thread	G 3/4	G 3/4	G 3/4
Square flange with internal thread	Rp 3/4	Rp 3/4	Rp 3/4
I-version			
Internal thread	Rp 3/4	Rp 3/4	Rp 3/4
	G 3/4	G 3/4	G 3/4

Installation length [mm]

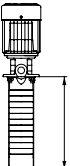
Pump	SPK 1	SPK 2	SPK 4
	140-1005	140-1005	140-1005

Shaft seal*

Pump	SPK 1	SPK 2	SPK 4
AUUV	•	•	•

* Other shaft seals on request.

MTH**50 Hz**

Pump	MTH 2	MTH 4	MTH 8	MTH 10	MTH 15
Rated flow rate [m ³ /h]	2.5	4	8	12	18
Rated flow rate [l/min]	42	67	133	200	300
Temperature range [°C]	-10 to +90				
Maximum efficiency [%]	45	50	60	60	63
Flow range [m ³ /h]	0.7 - 3.5	1.2 - 8	4-12	5-15	6-22
Flow range [l/min]	12-58	20-133	67-200	83-250	100-370
Maximum head [bar]	10	10	8	10	7
Motor power[kW]	0.55 - 1.1	0.55 - 2.2	0.55 - 3	1.1 - 4	1.1 - 4

60 Hz

Pump	MTH 2	MTH 4	MTH 8	MTH 10	MTH 15
Rated flow rate [m ³ /h]	3	4.8	9.6	14.4	21.6
Rated flow rate [l/min]	50	80	160	240	360
Temperature range [°C]	-10 to +90				
Maximum efficiency [%]	45	50	60	61	66
Flow range [m ³ /h]	0.7 - 4	1.2 - 8	4.6 - 14	8-18	10-26
Flow range [l/min]	12-67	20-133	77-233	133-320	167-433
Maximum head [bar]	10	10	10	10	5
Motor power[kW]	0.55 - 1.1	0.55 - 2.2	0.55 - 4	1.1 - 4	2.2 - 4

Material variants

Pump	MTH 2	MTH 4	MTH 8	MTH 10	MTH 15
Pump head (A-version): cast iron, EN-GJL-200	•	•	•	•	•
Pump head (I-version): stainless steel, EN 1.4408	•	•	•	•	•

Pipe connection

Pump	MTH 2	MTH 4	MTH 8	MTH 10	MTH 15
A-version					
Internal thread	Rp 3/4	Rp 3/4	Rp 3/4	-	-
Counterflange	-	-	-	G 1 1/4	G 1 1/4
I-version					
Internal thread	Rp 3/4	Rp 3/4	Rp 3/4	Rp 1 1/4	Rp 1 1/4
	-	-	-	G 1 1/4	G 1 1/4

Installation length [mm]

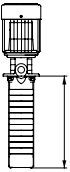
Pump	MTH 2	MTH 4	MTH 8	MTH 10	MTH 15
	145-289	145-334	145-334	105-255	105-255

Shaft seal*

Pump	MTH 2	MTH 4	MTH 8	MTH 10	MTH 15
AQQV	•	•	•	•	•

* Other shaft seals on request.

MTA**50 Hz**

Pump	MTA 30	MTA 60	MTA 90	MTA 120	MTA 200	MTA 20H	MTA 40H	MTA 70H	MTA 100H
Rated flow rate [l/min]	30	50	80	100	200	20	35	60	90
Temperature range [°C]	0-60								
Flow range [l/min]	0-45	0-82	0-111	0-200	0-355	0-47	0-67	0-95	0-112
Maximum head [m]	4.9	7.2	7.2	9.3	11.1	5.9	10.2	10.2	13.5

60 Hz

Pump	MTA 30	MTA 60	MTA 90	MTA 120	MTA 200	MTA 20H	MTA 40H	MTA 70H	MTA 100H
Rated flow rate [l/min]	35	60	96	120	250	24	42	72	108
Temperature range [°C]	0-60								
Flow range [l/min]	0-56	0-100	0-134	0-245	0-420	0-52	0-81	0-114	0-138
Maximum head [m]	7.1	10.1	10.2	13.3	15.6	8.4	14.2	14.6	19.1

Pipe connection

Pump	MTA 30	MTA 60	MTA 90	MTA 120	MTA 200	MTA 20H	MTA 40H	MTA 70H	MTA 100H
	Rp 3/8	Rp 1/2	Rp 3/4	Rp 1	Rp 2	Rp 3/8	Rp 1/2	Rp 3/4	Rp 1
Internal thread	G 1/2	G 3/4	G 3/4	G 1 1/4	G 1 1/2	G 1/2	G 3/4	G 3/4	G 1
	1/2" NPT	3/4" NPT	3/4" NPT	1 1/4" NPT	1 1/2" NPT	1/2" NPT	3/4" NPT	3/4" NPT	1" NPT

Material

Pump	MTA 30	MTA 60	MTA 90	MTA 120	MTA 200	MTA 20H	MTA 40H	MTA 70H	MTA 100H
Pump housing	Cast iron	Cast iron	Cast iron	Cast iron	Cast iron	Cast iron	Cast iron	Cast iron	Cast iron
Impeller	PAA GF50	PAA GF50	PAA GF50	PAA GF50	Bronze	Bronze	Bronze	Bronze	Bronze

Installation length [mm]

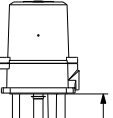
Pump	MTA 30	MTA 60	MTA 90	MTA 120	MTA 200	MTA 20H	MTA 40H	MTA 70H	MTA 100H
	150	130-350	130-350	180-350	250-350	150	180	250	280

Inlet

Pump	MTA 30	MTA 60	MTA 90	MTA 120	MTA 200	MTA 20H	MTA 40H	MTA 70H	MTA 100H
Top inlet	•	•	•	•	-	•	•	•	•
Bottom inlet	•	•	•	•	•	-	-	• 1)	-

1) Impeller material: PAA GF50

5. Motors

Motors for MTR and SPK pumps

MTR and SPK pumps are fitted with a totally enclosed, fan-cooled, 2-pole Grundfos standard MG motor with principal dimensions according to IEC, DIN and British standards.

Electrical tolerances according to EN 60034.

Mounting designation	Up to 4 kW	V 18/B 14
	From 5.5 kW	V 1/B 5
Efficiency class	0.06 - 0.55 kW	-
	0.75 - 45 kW	IE3
Enclosure class	IP55	
Insulation class	F	
Supply voltage, 50 Hz (- 10 %/+ 10 %)	0.06 - 45 kW	3 x 220-240 / 380-415 V
	0.37 - 5.5 kW	3 x 380-415 V Δ
	7.5 - 45 kW	3 x 380-415 / 660-690 V
Supply voltage, 60 Hz (- 10 %/+ 10 %)	0.06 - 0.18 kW	3 x 220-277 / 380-480 V
	0.25 - 1.1 kW	3 x 220-255 / 380-440 V
	1.5 - 45 kW	3 x 220-277 / 380-480 V
	0.37 - 5.5 kW	3 x 380-440 V Δ
	7.5 - 45 kW	3 x 380-480 / 660-690 V

MTR pumps are also available for these supply voltages

Supply voltage, 50 Hz	0.06 - 22 kW	3 x 200-220 / 346-380 V
	30-45 kW	
Supply voltage, 60 Hz	0.06 - 45 kW	3 x 200-230 / 346-400 V
	30-45 kW	
	0.25 - 45 kW	3 x 208-230 / 460-480 V

For detailed electrical data, see the section on motor data starting at the section on standard motors, MTR and SPK.

On request, Grundfos MG motors are available with cURus approvals carried out by the Underwriters Laboratories Inc. according to UL 1004 Electric motor standard.

Related information

[Standard motors, MTR and SPK](#)

Ambient temperature and installation altitude

The ambient temperature and the installation altitude are important factors for the motor life, as they affect the bearings and the insulation system. The installation altitude is the height of the installation site above sea level.

Motors installed at maximum ambient temperature and altitude can be loaded 100 %.

If the ambient temperature or the installation altitude exceeds the recommended maximum values, the motor must not be fully loaded due to the risk of overheating. Overheating may result from excessive ambient temperatures or high altitudes with low density and low cooling effect of the air.

In such cases, it may be necessary to select an oversized motor with a higher rated output. To determine the motor load, it is necessary to calculate the derated motor power.

Maximum ambient temperature and altitude for Grundfos MG and Siemens motors

The table shows the maximum permissible ambient temperature at full load and the maximum permissible installation altitude above sea level at full load.

Motor power [kW]	Motor make	Max. ambient temperature [°C]	Max. altitude [m]
0.06 - 0.18	Siemens	40	1000
0.25 - 0.55	Grundfos MG	40	1000
0.75 - 22	Grundfos MG	60	3500
30-45	Siemens	55	2750

Motor output derating factors

If the ambient temperature exceeds the maximum permissible temperature value or the pump is installed at an altitude exceeding the maximum permissible altitude value, the motor must not be fully loaded due to the risk of overheating. Overheating may result from excessive ambient temperatures or the low density and consequently low cooling effect of the air.

In such cases, it may be necessary to use a motor with a higher rated output.

Motor load for Grundfos MG and Siemens motors

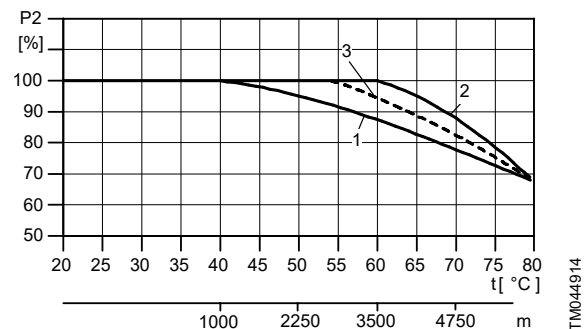

Maximum motor output in relation to ambient temperature and altitude

Derating curve	Motor power [kW]	Motor make	Motor efficiency class
1	0.06 - 0.18	Siemens	IE3
1	0.25 - 0.55	Grundfos MG	IE3
2	0.75 - 22	Grundfos MG	IE3
3	30-45	Siemens	IE3

Example of maximum motor load

Pump with a 2.2 kW IE3 motor (derating curve 2):

- If this pump is installed 4750 m above sea level, the motor must not be loaded more than 88 % of the rated output.
- At an ambient temperature of 75 °C, the motor must not be loaded more than 78 % of the rated output.
- If the pump is installed 4750 m above sea level at an ambient temperature of 75 °C, multiply the derating factors. The motor must not be loaded more than 88 % × 78 % = 68.6 % of the rated output.



If the motor load is not reduced in case the ambient temperature or installation altitude is exceeded, the motor life will be limited, and the warranty is void.

Motor protection

Single-phase Grundfos motors have a built-in thermal overload switch (IEC 34-11:TP 211).

Three-phase motors must be connected to a motor-protective circuit breaker in accordance with local regulations.

Three-phase Grundfos motors from 3 kW and upwards have a built-in thermistor (PTC) according to DIN 44082 (IEC 34-11:TP 211).

Motors for MTH pumps

MTH motors are totally enclosed, fan-cooled, 2-pole Grundfos standard motors with principal dimensions according to IEC, DIN and British standards.

Enclosure class	IP54
Insulation class	F
Supply voltage, 50 Hz (- 5 % / + 5 %)	3 x 220-240 / 380-415 V 3 x 200-220 / 346-380 V
Supply voltage, 60 Hz (- 5 % / + 5 %)	3 x 220-255 / 380-440 V 3 x 200-230 / 346-400 V 3 x 208-230 / 460 V

Ambient temperature

The motor used on an MTH pump is not shown in the list above, but the maximum ambient temperature at full load is the same as for MG motors.

Motors for MTA pumps

Efficiency class (only MTA 200, 750 W)	IE3
Enclosure class	IP54
Insulation class	F
Supply voltage, 50 Hz (- 10 %/+ 10 %)	3 x 220-240 / 380-415 V 3 x 200 V
Supply voltage, 60 Hz (- 10 %/+ 10 %)	3 x 220-240 / 380-440 V 3 x 200-220 V 3 x 208-230 / 460 V

We do not recommend operation via frequency converter. The motors for MTA pumps are exempt from the efficiency requirements set out under the Ecodesign regulation (EU) 2019/1781 and Regulation (EU) 2021/341 (Ecodesign omnibus amendment). This is due to the following reason: if the pump part is removed from an MTA pump, the motor will be inoperative.

Ambient temperature

Maximum permissible ambient temperature: 40 °C

Terminal box positions

MTR, MTRE, SPK and MTH

Pump	Terminal box positions			
	3 o'clock	6 o'clock (standard)	9 o'clock	12 o'clock
MTR	•	•	•	•
MTRE	•	•	•	•
SPK	•	•	•	•
MTH	•	•	•	-

MTA

Pump	Terminal box positions			
	3 o'clock	6 o'clock	9 o'clock (standard)	12 o'clock
MTA 30	•	-	•	-
MTA 60	•	(•)	•	(•)
MTA 90	•	(•)	•	(•)
MTA 120	(•)	(•)	•	(•)
MTA 200	(•)	(•)	•	(•)
MTA 20H	•	-	•	-
MTA 40H	•	(•)	•	(•)
MTA 70H	•	(•)	•	(•)
MTA 100H	(•)	(•)	•	(•)

• This position is possible. The pump can be ordered with the terminal box in this position, or the terminal box can be turned to this position after delivery.

(•) This position is possible, but the terminal box cannot be turned to this position after delivery. Therefore, the pump must be ordered with the terminal box in this position.

- This position is not possible.

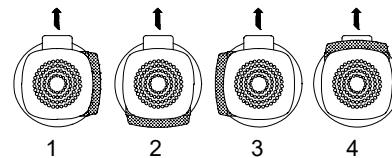

TM027777

Terminal box positions, top view

Pos.	Description
1	Position 3 o'clock
2	Position 6 o'clock
3	Position 9 o'clock
4	Position 12 o'clock

Frequency of starts and stops

Pump	Motor size [kW]	Maximum number of starts per hour
MTR	0.06 - 0.18	100
	0.25 - 2.2	250
SPK	3-4	100
MTH	5.5 - 11	50
	15-22	40

Pump	Motor size [kW]	Maximum number of starts per hour
	30	90
	37	50
	45	80
MTA	All	250

Sound pressure level

Pump	Motor power[kW]	LpA [dB(A)]	
		50 Hz	60 Hz
MTR SPK	0.06	41	41
	0.12	41	41
	0.18	41	41
	0.25	56	62
	0.37	50	55
	0.55	50	53
	0.75	50	54
	1.1	52	57
	1.5	54	59
	2.2	54	59
	3.0	55	60
	4.0	62	66
	5.5	60	65
	7.5	60	65
	11	60	65
	15	60	65
	18.5	60	65
	22	66	70
	30	67	75
37	67	75	
45	67.5	75	
MTH		< 70	< 70
MTA 30		< 45	< 45
MTA 60		< 45	< 45
MTA 90		< 45	< 45
MTA 120		< 62	< 62
MTA 200		< 62	< 62
MTA 20H		< 45	< 45
MTA 40H		< 45	< 45
MTA 70H		< 45	< 45
MTA 100H		< 62	< 62

The values have been measured according to EN ISO 4871.

Optional motors

The Grundfos standard range of motors meets a wide variety of system requirements.

For special applications or operating conditions, we offer custom-built motors, such as the following:

- ATEX-approved motors
- MG motors with anti-condensation heating unit
- motors with thermal protection.

Related information

[List of variants, on request](#)

Motors for MTRE pumps

MTRE pumps are fitted with a totally enclosed, fan-cooled, 2-pole frequency-controlled Grundfos MGE motor with principal dimensions in accordance with the EN standards.

Electrical tolerances comply with EN 60034.

MTRE pumps from 0.37 to 26 kW are fitted with three-phase MGE motors as standard.

0.37 to 1.5 kW single-phase MGE motors are available on request.

For more information see Grundfos Product Center at <http://product-selection.grundfos.com/>.

Related information

[16. Grundfos Product Center](#)

Electrical data

MGE motor	
Mounting designation	Up to 4 kW: V18 5.5 kW and up: V1
Insulation class	F
Efficiency class	0.37 to 26 kW: IE5 level
Enclosure class	0.37 to 26 kW: IP55 (IP66 optional)
Supply voltage	P2: 0.37 - 1.5 kW: 1 x 200-240 V
	P2: 1.1 - 5.5 kW 3 x 200-240 V
Tolerance: - 10 %/+ 10 %	P2: 0.37 - 11 kW: 3 x 380-500 V
	P2: 15 - 26 kW: 3 x 380-480 V
Supply frequency	50/60 Hz

Maximum ambient temperature and altitude for Grundfos MGE motors

The table shows the maximum permissible ambient temperature at full load and the maximum permissible installation altitude above sea level at full load.

Motor efficiency class: IE5

Motor power [kW]	Motor make	Phase	Max. ambient temperature [°C]	Max. altitude above sea level [m]
0.37 - 1.5	MGE	1	50	1000
0.37 - 11	MGE	3	50 ²⁾	1000
15-22	MGE	3	50	1000
26	MGE	3	40	1000

²⁾ 3 x 200-240 V MGE motors are rated for a maximum ambient temperature of 40 °C.

Motor load for Grundfos MGE motors

MGE motors can be installed up to 3500 metres above sea level.

Motors installed above the maximum installation altitude of 1000 metres above sea level must not be fully loaded. Use the below curve to calculate the derated motor power. If the required motor output exceeds the derated motor power, select an oversized motor.

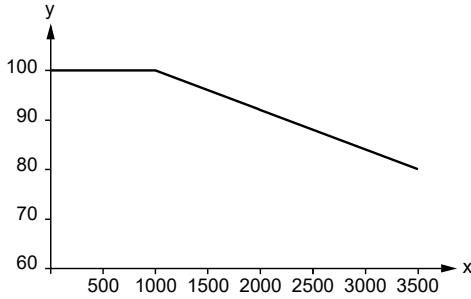

Derating of motor output power P2 % (y-axis) in relation to installation altitude above sea level in metres (x-axis)

Motor protection

MGE motors incorporate thermal protection against slow overload and blocking (IEC 34-11:TP 211).

Grundfos pumps with MGE motor require no external motor protection.

Bluetooth

For MGE motors from 15 to 26 kW, the product incorporates a Bluetooth (BLE) module for remote control. For MGE motors from 0.37 to 11 kW, see the detailed description about Grundfos GO.

Via the built-in Bluetooth module, the product can communicate with Grundfos GO. Bluetooth communication can take place at distances up to 10 metres.

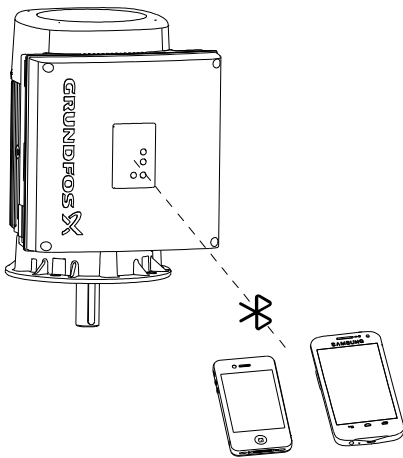

TM082930

Bluetooth information

Frequency of operation	2400 - 2483.5 MHz
Modulation type	GFSK
Data rate	2 Mbps
Transmit power	5 dBm EIRP with internal antenna

GLoWpan information

Frequency of operation	2405-2480 MHz
Modulation type	GP O-QPSK
Data rate	1 Mbps
Transmit power	5 dBm EIRP with internal antenna

Grundfos GO Link

The product is designed for wired or wireless communication with Grundfos GO Link.

Grundfos GO Link enables you to set functions and gives you access to status overviews, configuration and current operating parameters.

Use Grundfos GO Link together with these interfaces:

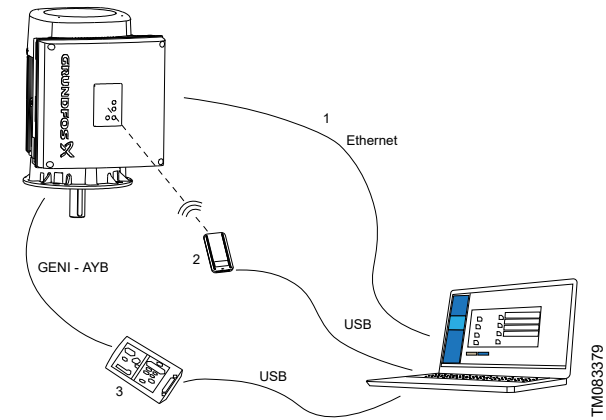

TM083379

Grundfos GO Link setup

Pos.	Description
1	Ethernet cable: Standard Ethernet cable CAT5/CAT6.
2	Grundfos MI 301: Separate module enabling radio communication. Use the module together with a USB cable to connect to a laptop.
3	Grundfos PC Tool Link: Separate module enabling wired connection to the pump. Use the module together with a USB cable to connect to a laptop.

Safe Torque Off (STO) function

Safe Torque Off (STO) is a safety function with the purpose to stop the motor from turning, without actively braking it. It follows the definition by EN 61800-5-2.

The STO safety function's main difference from a functional stop using a digital input (for example DI1) is the fact that STO is approved to provide a defined safety integrity.

The principle of operation is the following:

1. The STO function is activated (the input circuits are opened, for example by opening contactors).
2. The STO inputs of the motor de-energize.
3. The motor cuts off the control signal for the output transistors.
4. The motor coasts to a stop if it is running. The drive cannot restart while the STO function is activated. After deactivating STO, the motor can restart immediately.
5. The control software of the motor generates an STO alert and corresponding indications. The STO alert can be configured. See the section on STO alert handling.

The version of the STO function is marked on the motor nameplate, after the product version number.

Safety approvals

The Safe Torque Off (STO) function of the E-pump with an MGE, MLE motor complies with the following standards:

Rating	Standard
Definition of safety function STO	IEC 61800-5-2:2016
Safety Integrity Level SIL3	IEC 61508-1/-2:2010
Performance level e (PL e)	EN ISO 13849-1:2015
Category 3	EN ISO 13849-1:2015

Functional module, FM300

MGE 0.37 to 11 kW

The FM300 is factory-fitted in all pumps from 0.37 to 11 kW.

The module has a number of inputs and outputs enabling the motor to be used in advanced applications where many inputs and outputs are required.

The FM300 has these connections:

- three analog inputs
- one analog output
- two dedicated digital inputs
- two configurable digital inputs or open-collector outputs
- Grundfos Digital Sensor input and output
- two Pt100/1000 inputs
- two LiqTec sensor inputs
- two signal relay outputs
- GENIbus connection.

Connection terminals

All inputs and outputs are internally separated from the mains-conducting parts by reinforced insulation and galvanically separated from other circuits. All control terminals are supplied with protective extra-low voltage (PELV), thus ensuring protection against electric shock.

- Signal relay outputs
 - Signal relay 1:
 - LIVE: Power supply voltages up to 250 VAC can be connected to this output.
 - PELV: The output is galvanically separated from other circuits. Therefore, the supply voltage or protective extra-low voltage can be connected to the output as desired.
 - Signal relay 2:
 - PELV: The output is galvanically separated from other circuits. Therefore, the supply voltage or protective extra-low voltage can be connected to the output as desired.
- **Power supply** (terminals N, PE, L or L1, L2, L3, PE)

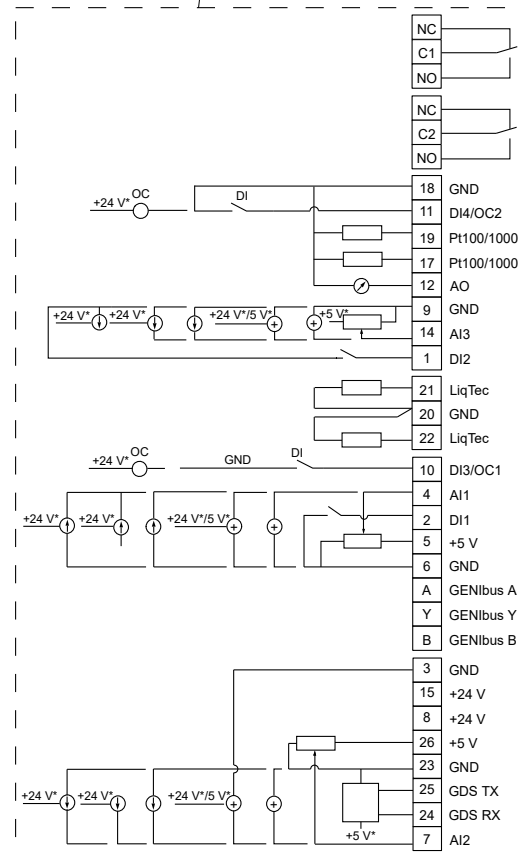
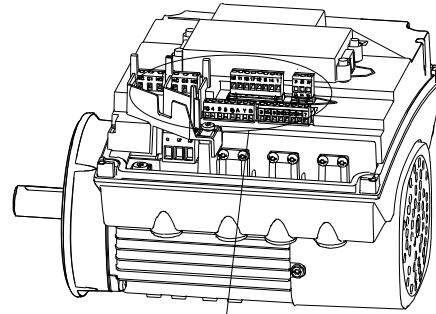

TM063509

* If an external supply source is used, there must be a connection to GND.

Connection terminals, FM300 functional module

Functional module, FM310 and FM311

MGE 15 to 26 kW

FM310 and FM311 are factory-fitted in all pumps from 15 to 26 kW.

Inputs and outputs

Note that the FM311 functional module does not include Bluetooth connection.

The module has these connections:

- three analog inputs
- one analog output
- two dedicated digital inputs
- two configurable digital inputs or open-collector outputs
- Grundfos Digital Sensor input and output
- two Pt100/1000 inputs
- two LiqTec sensor inputs
- two signal relay outputs
- GENIbus/Modbus connection
- two Safe Torque Off (STO) inputs³⁾
- Ethernet connection
- Bluetooth (BLE) connection.⁴⁾

³⁾ Safe Torque Off (STO) is a safety function with the purpose to stop the motor from turning, without actively braking it. It follows the definition by EN 61800-5-2.

⁴⁾ FM311 is without Bluetooth.

Connection terminals

All control terminals are supplied with safety extra-low voltage (SELV), ensuring protection against electric shock.

The inputs and outputs are internally separated from the mains-conducting parts by reinforced insulation and galvanically separated from other circuits.

Cables for the relays and the Ethernet cable must be rated at least 250V/2A.

The relays are approved for overvoltage category II, whether power is supplied from a transformer or the power supply.

Signal relay outputs

Signal relay 1

LIVE: You can connect supply voltages up to 250 VAC to the output.

SELV: The output is galvanically separated from other circuits. Therefore, you can connect the supply voltage or safety extra-low voltage to the output as desired.

Signal relay 2

SELV: The output is galvanically separated from other circuits. Therefore, you can connect the supply voltage or safety extra-low voltage to the output as desired.

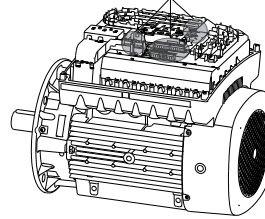
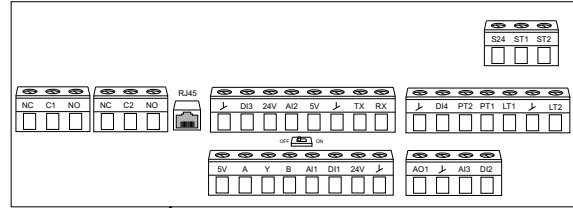

TM082862

Terminal	Type	Function
NC	Normally closed contact	
C1	Common	Signal relay 1: LIVE or SELV
NO	Normally open contact	
NC	Normally closed contact	
C2	Common	Signal relay 2: SELV only
NO	Normally open contact	
RJ45	Ethernet	Ethernet communication
GND	GND	Signal ground
DI3	DI3/OC1	Digital input/output, configurable Open collector: Maximum 24 V resistive or inductive
24V	+24 V	Power supply
AI2	AI2	Analog input: • 0-20 mA or 4-20 mA • 0.5 - 3.5 V, 0-5 V or 0-10 V.
5V	+5 V	Power supply to a potentiometer or sensor
GND	GND	Signal ground
TX	GDS TX	Grundfos Digital Sensor output
RX	GDS RX	Grundfos Digital Sensor input
GND	GND	Signal ground
DI4	DI4/OC2	Digital input/output, configurable Open collector: Maximum 24 V resistive or inductive
PT2	Pt100/1000 input 2	Pt100/1000 sensor input 2
PT1	Pt100/1000 input 1	Pt100/1000 sensor input 1
LT1	LiqTec sensor input 1	LiqTec sensor input 1 White conductor
GND	GND	Signal ground Brown and black conductors
LT2	LiqTec sensor input 2	LiqTec sensor input 2 Blue conductor
5V	+5 V	Power supply to a potentiometer or sensor
A	GENIbus, A	GENIbus, A (+) / Modbus, D1 (+)
Y	GENIbus, Y	GENIbus, GND / Modbus, GND
B	GENIbus, B	GENIbus, B (-) / Modbus, D0 (-)
AI1	AI1	Analog input: • 0-20 mA or 4-20 mA • 0.5 - 3.5 V, 0-5 V or 0-10 V.

Terminal	Type	Function
DI1	DI1	Digital input ⁵⁾ , configurable
24V	+24 V	Power supply
GND	GND	Signal ground
AO1	AO	Analog output: • 0-20 mA or 4-20 mA • 0-10 V.
GND	GND	Signal ground
AI3	AI3	Analog input: • 0-20 mA or 4-20 mA • 0.5 - 3.5 V, 0-5 V or 0-10 V.
DI2	DI2	Digital input, configurable
S24	+24 V (STO)	Power supply to the Safe Torque Off inputs
ST1	STO1	Safe Torque Off - Input 1
ST2	STO2	Safe Torque Off - Input 2

⁵⁾ Digital input 1 is factory-set to be start or stop input where an open circuit results in stop. A jumper has been factory-fitted between terminals DI1 and GND. Remove the jumper if digital input 1 is to be used as external start or stop or any other external function.

6. Control of MTRE pumps

Control options

It is possible to communicate with E-pumps via the following platforms:

- the operating panel on the pump
- Grundfos GO
- Grundfos GO Link
- central management system.

The purpose of controlling an E-pump is to monitor and control the pressure, temperature, flow and liquid level of the system.

Operating panels

The operating panel on the E-pump terminal box makes it possible to change the setpoint settings manually. All settings are saved if the power supply is switched off.

The following operating panels are available as standard:

- HMI 200
- HMI 300

Note that these panels include an integrated radio module.

The following operating panels, without an integrated radio module, are available on request:

- HMI 100
- HMI 101
- HMI 201
- HMI 301

For further information, see the section on variants.

Related information

[List of variants, on request](#)

HMI 200

This operating panel is available as standard.

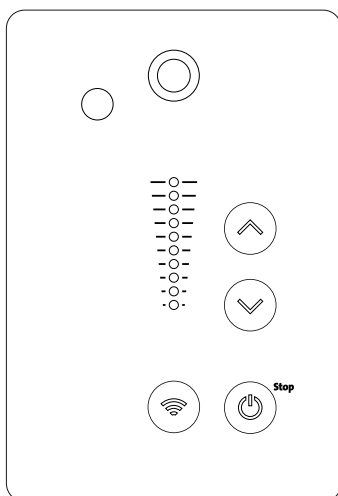

TM084861

HMI 300

This operating panel is available as either standard or an option depending on the region.

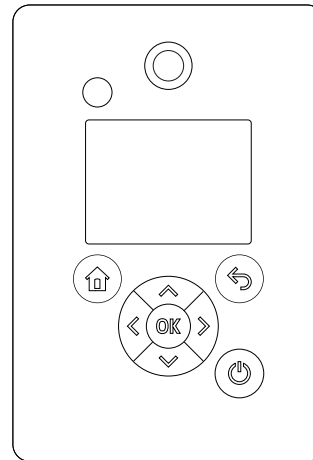

TM084862

Grundfos GO

Grundfos GO enables you to set functions and gives you access to status overviews, technical product information and current operating parameters.

MGE 0.37 to 11 kW

The product is designed for wireless radio or infrared communication with Grundfos GO.

Use Grundfos GO together with this mobile interface:

- Grundfos MI 301.

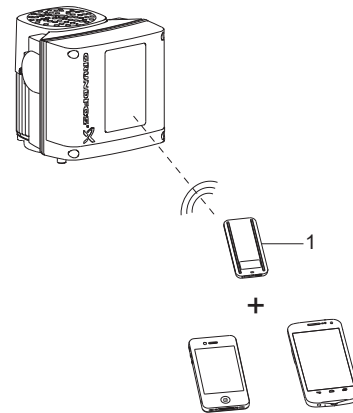

TM066256

Pos.	Description
1	Grundfos MI 301: Separate module enabling radio or infrared communication. Use the module together with an Android or iOS-based smart device via a Bluetooth connection.

MGE 15 to 26 kW

The product is designed for wireless communication with Grundfos GO using Bluetooth (BLE).

Via the built-in Bluetooth module, the product can communicate with Grundfos GO.

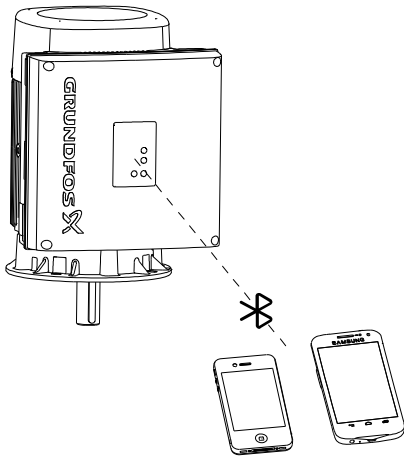

TM082930

Communication using Grundfos GO

When Grundfos GO initiates communication with the product, the indicator light in the centre of Grundfos Eye flashes green.

You can use these communication types:

- radio communication
- infrared communication.

Radio communication

Radio communication can take place at distances up to 30 metres. The first time Grundfos GO communicates with the product, you enable communication by pressing the **Radio communication** button or **OK** on the operating panel.

Later when communication takes place, the product is recognized by Grundfos GO, and you can select the product from the **List** menu.

Infrared communication

Infrared communication can take place at distances up to 2 m. When communicating via infrared light, Grundfos GO must be pointed at the operating panel of the product.

Central management system

Communication with the E-pump is possible even if the operator is not present near the E-pump. Communication is enabled by connecting the E-pump to a central building management system. This allows the operator to monitor the pump and change control modes and setpoint settings.

Communication between E-pumps and a central building management system is enabled via a Grundfos CIM module.

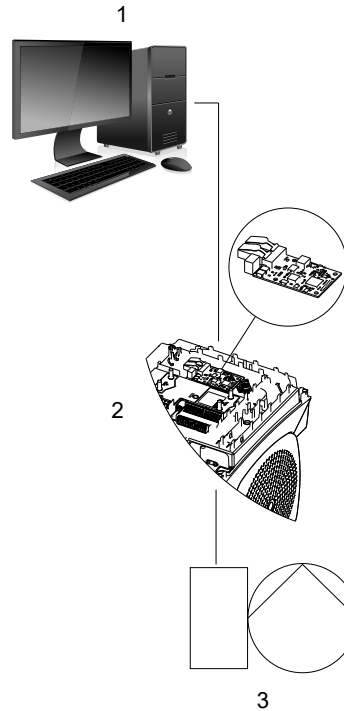

TM084691

Structure of a central management system

Pos.	Description
1	Central management system
2	CIM modules (See the section on CIM communication interface modules)
3	E-pump

Control modes for MTRE pumps

Grundfos MTRE pumps are only available without a pressure sensor.

E-pumps without a sensor

E-pumps without a sensor are suitable in these situations:

- Uncontrolled operation is required.
- The sensor has been retrofitted to control the flow rate, temperature, differential temperature, liquid level and pH value at some arbitrary point in the system.

E-pumps without a sensor can be set to any of these control modes:

- constant pressure
- constant differential pressure
- constant temperature
- constant differential temperature
- constant flow rate
- constant level
- constant curve
- constant other value.

E-pumps without a sensor can be set to either of these control modes:

- controlled operation
- uncontrolled operation (factory setting).

In controlled-operation mode, the pump adjusts its performance to the desired setpoint. See the figure below.

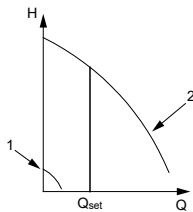

TM027264

Constant-flow mode

Pos.	Description
1	Min.
2	Max.

In uncontrolled-operation mode, the pump operates according to the constant curve set. See the figure below.

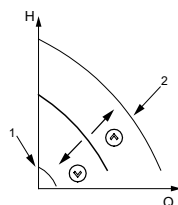

TM009323

Constant-curve mode

Pos.	Description
1	Min.
2	Max.

E-pumps can be fitted with a sensor type meeting the requirements mentioned in the Grundfos E-pumps data booklet available in Grundfos Product Center at www.grundfos.com.

MTRE 1s, 1, 3 and 5 pumps with extended performance range

Standard MTRE 1s, 1, 3 and 5 pumps can operate in a range above the 100 % curve.

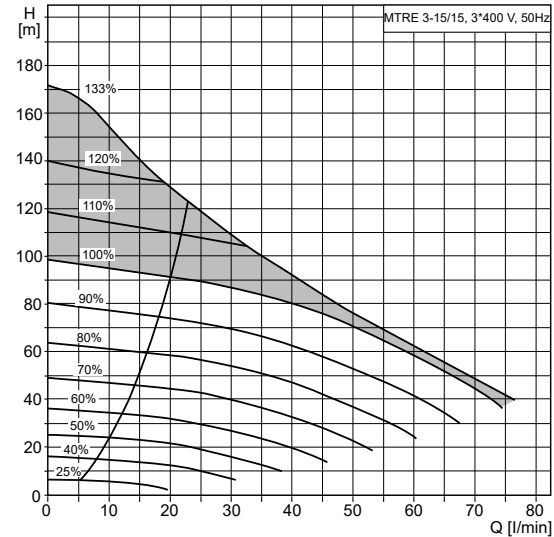

TM067701

MTRE 1s, 1, 3 and 5 pumps with extended performance range

- Pumped liquid: Water
- Liquid temperature: 20 °C
- Density: 998.2 kg/m³

The extended range is provided by means of optimised software which uses the MGE motor in an optimum way. The result is that the pump can deliver a higher head and flow rate with the same motor size.

The curve sheets in this data booklet only show the nominal 100 % QH curve.

Grundfos Product Center shows the extended performance range of the pumps.

Related information

[16. Grundfos Product Center](#)

7. Construction

Construction of MTR pumps

MTR, MTRE 1s, 1, 3, 5, 8

Sectional drawing

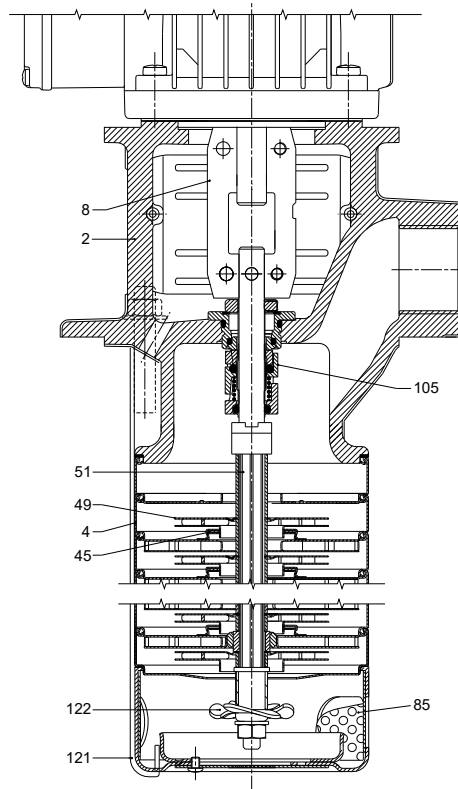

TM028687

MTR, MTRE 1s, 1, 3, 5 and 8

Materials

Pos.	Description	A-version			I-version			N-version		
		Materials	EN/DIN	AISI/ASTM	Materials	EN/DIN	AISI/ASTM	Materials	EN/DIN	AISI/ASTM
2	Pump head	Cast iron	EN-GJL-200	ASTM 25B	Stainless steel	1.4408	CF8M	Stainless steel	1.4408	CF8M
4	Chamber	Stainless steel	1.4301	AISI 304	Stainless steel	1.4301	AISI 304	Stainless steel	1.4401	AISI 316
8	Coupling	Sintered metal	-	-	Sintered metal	-	-	Sintered metal	-	-
45	Neck ring	PTFE	-	-	PTFE	-	-	PTFE	-	-
47a	Bearing ring, stationary	Silicon carbide	-	-	Silicon carbide	-	-	Silicon carbide	-	-
47b	Bearing ring, rotating	Silicon carbide	-	-	Silicon carbide	-	-	Silicon carbide	-	-
49	Impeller	Stainless steel	1.4301	AISI 304	Stainless steel	1.4301	AISI 304	Stainless steel	1.4401	AISI 316
51	Pump shaft	Stainless steel	1.4401	AISI 316	Stainless steel	1.4401	AISI 316	Stainless steel	1.4401	AISI 316
84	Inlet strainer	Stainless steel	1.4301	AISI 304	Stainless steel	1.4301	AISI 304	Stainless steel	1.4401	AISI 316
85	Strainer internal	Stainless steel	1.4301	AISI 304	Stainless steel	1.4301	AISI 304	Stainless steel	1.4401	AISI 316
105	Shaft seal	HUUUV/HUUE	-	-	HUUUV/HUUE	-	-	HUUUV/HUUE	-	-
121	Strap	Stainless steel	1.4301	AISI 304	Stainless steel	1.4301	AISI 304	Stainless steel	1.4539	AISI 904L
122	Priming screw	Stainless steel	1.4301	AISI 304	Stainless steel	1.4301	AISI 304	Stainless steel	1.4401	AISI 316

MTR, MTRE 1s, 1, 3, 5 and 8 with drainage back to the tank

Sectional drawing

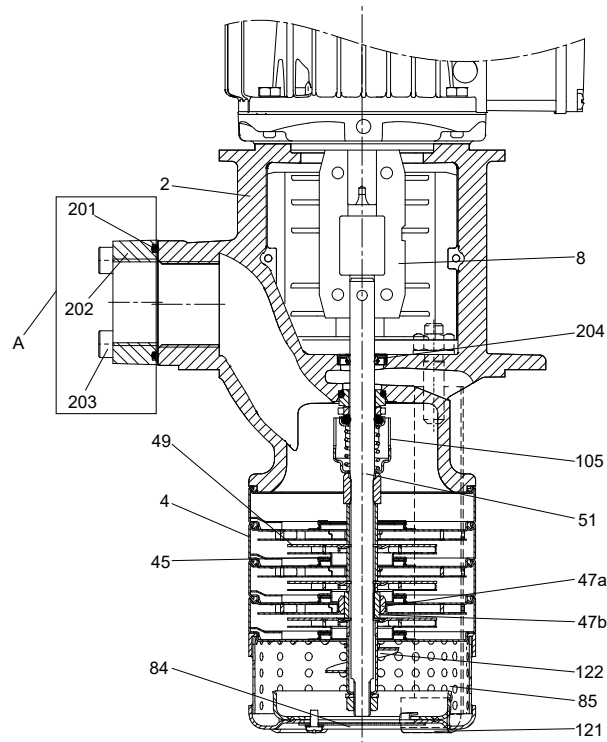

TM060196

MTR, MTRE 1s, 1, 3, 5 and 8 with drainage back to the tank. A: Counterflange is only available for A-version

Materials

Pos.	Description	A-version			I-version			N-version		
		Materials	EN/DIN	AISI/ASTM	Materials	EN/DIN	AISI/ASTM	Materials	EN/DIN	AISI/ASTM
2	Pump head	Cast iron	EN-GJL-200	ASTM 25B	Stainless steel	1.4408	CF8M	Stainless steel	1.4408	CF8M
4	Chamber	Stainless steel	1.4301	AISI 304	Stainless steel	1.4301	AISI 304	Stainless steel	1.4401	AISI 316
8	Coupling	Sintered metal	-	-	Sintered metal	-	-	Sintered metal	-	-
45	Neck ring	PTFE	-	-	PTFE	-	-	PTFE	-	-
47a	Bearing ring, stationary	Silicon carbide	-	-	Silicon carbide	-	-	Silicon carbide	-	-
47b	Bearing ring, rotating	Silicon carbide	-	-	Silicon carbide	-	-	Silicon carbide	-	-
49	Impeller	Stainless steel	1.4301	AISI 304	Stainless steel	1.4301	AISI 304	Stainless steel	1.4401	AISI 316
51	Pump shaft	Stainless steel	1.4401	AISI 316	Stainless steel	1.4401	AISI 316	Stainless steel	1.4401	AISI 316
84	Inlet strainer	Stainless steel	1.4301	AISI 304	Stainless steel	1.4301	AISI 304	Stainless steel	1.4401	AISI 316
85	Strainer internal	Stainless steel	1.4301	AISI 304	Stainless steel	1.4301	AISI 304	Stainless steel	1.4401	AISI 316
105	Shaft seal	AQQV/AQQE	-	-	HUUV/HUUE	-	-	HUUV/HUUE	-	-
121	Strap	Stainless steel	1.4301	AISI 304	Stainless steel	1.4301	AISI 304	Stainless steel	1.4539	AISI 904L
122	Priming screw	Stainless steel	1.4301	AISI 304	Stainless steel	1.4301	AISI 304	Stainless steel	1.4401	AISI 316
201	O-ring	NBR	-	-	-	-	-	-	-	-
202	Counterflange	Cast iron	EN-GJL-200	ASTM 25B	-	-	-	-	-	-
203	Bolt	Stainless steel	-	-	-	-	-	-	-	-
204	Lip seal	FKM	-	-	FKM	-	-	FKM	-	-

MTR, MTRE 10, 15, 20

Sectional drawing

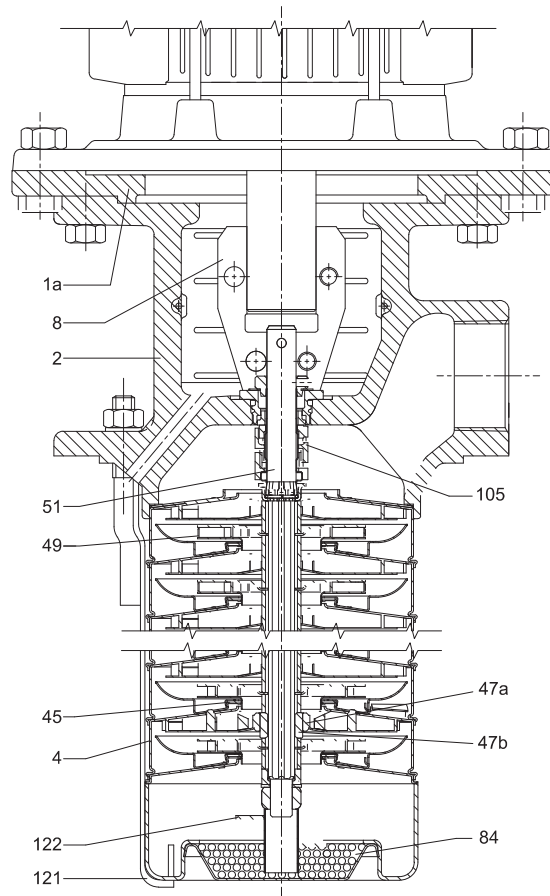

TM028688

MTR, MTRE 10, 15 and 20

Materials

Pos.	Description	A-version			I-version			N-version		
		Materials	EN/DIN	AISI/ASTM	Materials	EN/DIN	AISI/ASTM	Materials	EN/DIN	AISI/ASTM
1a	Motor stool	Cast iron	EN-GJL-200	ASTM 25B	Cast iron	EN-GJL-200	ASTM 25B	Cast iron	EN-GJL-200	ASTM 25B
2	Pump head	Cast iron	EN-GJL-200	ASTM 25B	Stainless steel	1.4408	CF8M	Stainless steel	1.4408	CF8M
4	Chamber	Stainless steel	1.4301	AISI 304	Stainless steel	1.4301	AISI 304	Stainless steel	1.4401	AISI 316
8	Coupling	Sintered metal	-	-	Sintered metal	-	-	Sintered metal	-	-
45	Neck ring	PTFE	-	-	PTFE	-	-	PTFE	-	-
47a	Bearing ring, stationary	Silicon carbide	-	-	Silicon carbide	-	-	Silicon carbide	-	-
47b	Bearing ring, rotating	Silicon carbide	-	-	Silicon carbide	-	-	Silicon carbide	-	-
49	Impeller	Stainless steel	1.4301	AISI 304	Stainless steel	1.4301	AISI 304	Stainless steel	1.4401	AISI 316
51	Pump shaft	Stainless steel	1.4057	AISI 431	Stainless steel	1.4460		Stainless steel	1.4460	
84	Inlet strainer	Stainless steel	1.4301	AISI 304	Stainless steel	1.4301	AISI 304	Stainless steel	1.4401	AISI 316
105	Shaft seal	HUUV/HUUE	-	-	HUUV/HUUE	-	-	HUUV/HUUE	-	-
121	Strap	Stainless steel	1.4301	AISI 304	Stainless steel	1.4301	AISI 304	Stainless steel	1.4539	AISI 904L
122	Priming screw	Stainless steel	1.4301	AISI 304	Stainless steel	1.4301	AISI 304	-	-	-

MTR, MTRE 10, 15 and 20 with drainage back to the tank

Sectional drawing

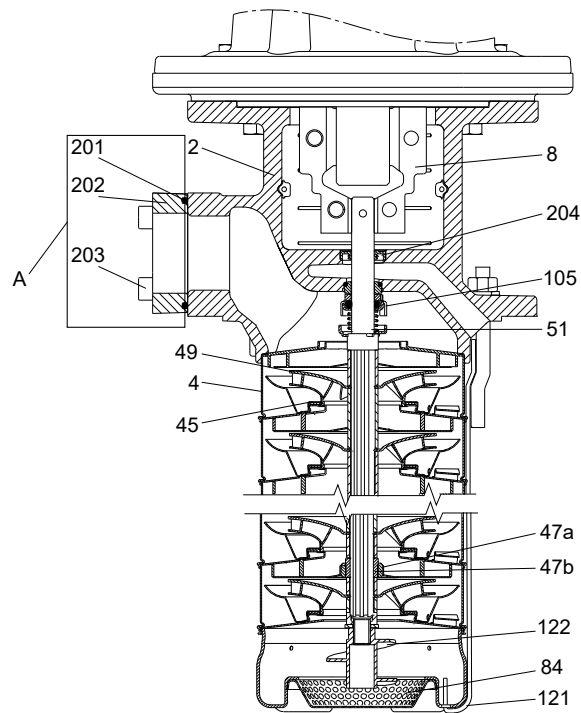

TMO61430

MTR, MTRE 10, 15 and 20 with drainage back to the tank. A: Counterflange is only available for A-version

Materials

Pos.	Description	A-version			I-version			N-version		
		Materials	EN/DIN	AISI/ASTM	Materials	EN/DIN	AISI/ASTM	Materials	EN/DIN	AISI/ASTM
1a	Motor stool	Cast iron	EN-GJL-200	ASTM 25B	Cast iron	EN-GJL-200	ASTM 25B	Cast iron	EN-GJL-200	ASTM 25B
2	Pump head	Cast iron	EN-GJL-200	ASTM 25B	Stainless steel	1.4408	CF8M	Stainless steel	1.4408	CF8M
4	Chamber	Stainless steel	1.4301	AISI 304	Stainless steel	1.4301	AISI 304	Stainless steel	1.4401	AISI 316
8	Coupling	Sintered metal	-	-	Sintered metal	-	-	Sintered metal	-	-
45	Neck ring	PTFE	-	-	PTFE	-	-	PTFE	-	-
47a	Bearing ring, stationary	Silicon carbide	-	-	Silicon carbide	-	-	Silicon carbide	-	-
47b	Bearing ring, rotating	Silicon carbide	-	-	Silicon carbide	-	-	Silicon carbide	-	-
49	Impeller	Stainless steel	1.4301	AISI 304	Stainless steel	1.4301	AISI 304	Stainless steel	1.4401	AISI 316
51	Pump shaft	Stainless steel	1.4057	AISI 431	Stainless steel	1.4460		Stainless steel	1.4460	
84	Inlet strainer	Stainless steel	1.4301	AISI 304	Stainless steel	1.4301	AISI 304	Stainless steel	1.4401	AISI 316
105	Shaft seal	AQQV/AQQE	-	-	HUUV/HUUE	-	-	HUUV/HUUE	-	-
121	Strap	Stainless steel	1.4301	AISI 304	Stainless steel	1.4301	AISI 304	Stainless steel	1.4539	AISI 904L
122	Priming screw	Stainless steel	1.4301	AISI 304	Stainless steel	1.4301	AISI 304	-	-	-
201	O-ring	NBR	-	-	-	-	-	-	-	-
202	Counterflange	Cast iron	EN-GJL-200	ASTM 25B	-	-	-	-	-	-
203	Bolt	Stainless steel	-	-	-	-	-	-	-	-
204	Lip seal	FKM	-	-	FKM	-	-	FKM	-	-

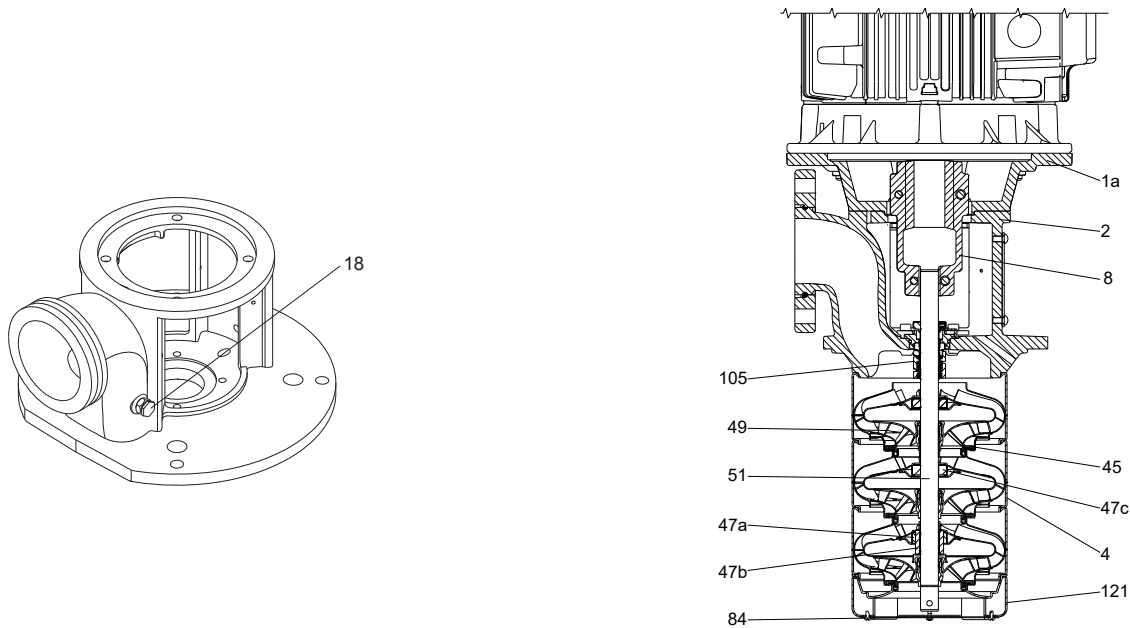
MTR, MTRE 32, 45, 64**Sectional drawing**

TM067514

MTR, MTRE 32, 45 and 64

Materials

Pos.	Description	A-version			I-version			N-version		
		Materials	EN/DIN	AISI/ASTM	Materials	EN/DIN	AISI/ASTM	Materials	EN/DIN	AISI/ASTM
1a	Motor stool	Cast iron	EN-GJL-200	ASTM 25B	Cast iron	EN-GJL-200	ASTM 25B	Cast iron	EN-GJL-200	ASTM 25B
2	Pump head	Cast iron	EN-GJL-200	ASTM 25B	Stainless steel	1.4408	CF8M	Stainless steel	1.4408	CF8M
4	Chamber	Stainless steel	1.4301	AISI 304	Stainless steel	1.4301	AISI 304	Stainless steel	1.4401	AISI 316
8	Coupling	Nodular iron	EN-GJS-500-7	ASTM 80-55-06	Nodular iron	EN-GJS-500-7	ASTM 80-55-06	Nodular iron	EN-GJS-500-7	ASTM 80-55-06
18	Vent screw	Stainless steel	1.4301	AISI 304	Stainless steel	1.4301	AISI 304	Stainless steel	1.4401	AISI 316
45	Neck ring	PTFE	-	-	PTFE	-	-	PTFE	-	-
47a	Bearing ring, stationary	Silicon carbide	-	-	Silicon carbide	-	-	Silicon carbide	-	-
47b	Bearing ring, rotating	Silicon carbide	-	-	Silicon carbide	-	-	Silicon carbide	-	-
47c	Bush	Graflon®, HY49	-	-	Graflon®, HY49	-	-	Graflon®, HY49	-	-
49	Impeller	Stainless steel	1.4301	AISI 304	Stainless steel	1.4301	AISI 304	Stainless steel	1.4401	AISI 316
51	Pump shaft	Stainless steel	1.4057	AISI 431	Stainless steel	1.4462	-	Stainless steel	1.4462	-
-	O-ring*	A-version: NBR	-	-	Depending on rubber material in shaft seal	-	-	Depending on rubber material in shaft seal	-	-
84	Inlet strainer	Stainless steel	1.4301	AISI 304	Stainless steel	1.4301	AISI 304	Stainless steel	1.4401	AISI 316
105	Shaft seal	HUUUV/HUUE	-	-	HUUUV/HUUE	-	-	HUUUV/HUUE	-	-
121	Strap	Stainless steel	1.4301	AISI 304	Stainless steel	1.4301	AISI 304	Stainless steel	1.4539	AISI 904L

* Only used in pumps with empty chambers.

MTR, MTRE 32, 45 and 64 with drainage back to the tank

Sectional drawing

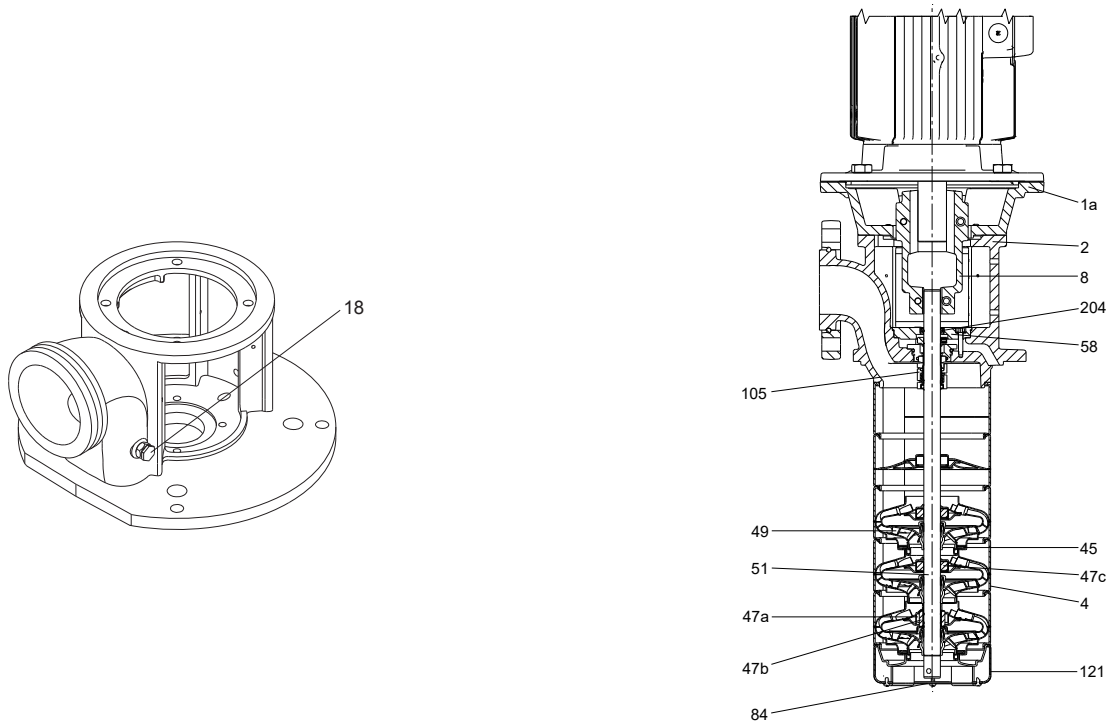

TM1040166

MTR, MTRE 32, 45 and 64 with drainage back to the tank

Materials

Pos.	Description	Materials	A-version	
			EN/DIN	AISI/ASTM
1a	Motor stool	Cast iron	EN-GJL-200	ASTM 25B
2	Pump head	Cast iron	EN-GJL-200	ASTM 25B
4	Chamber	Stainless steel	1.4301	AISI 304
8	Coupling	Nodular iron	EN-GJS-500-7	ASTM 80-55-06
18	Vent screw	Stainless steel	1.4301	AISI 304
45	Neck ring	PTFE	-	-
47a	Bearing ring, stationary	Silicon carbide	-	-
47b	Bearing ring, rotating	Silicon carbide	-	-
47c	Bush	Graflon®, HY49	-	-
49	Impeller	Stainless steel	1.4301	AISI 304
51	Pump shaft	Stainless steel	1.4057	AISI 431
-	O-ring*	A-version: NBR	-	-
84	Inlet strainer	Stainless steel	1.4301	AISI 304
105	Shaft seal	HUUU/HUUE	-	-
58	Shaft seal cover	Cast iron	EN-GJL-200	ASTM 25B
121	Strap	Stainless steel	1.4301	AISI 304
204	Lip seal	FKM	-	-

* Only used in pumps with empty chambers.

Construction of SPK pumps

SPK 1, 2, 4

Sectional drawing

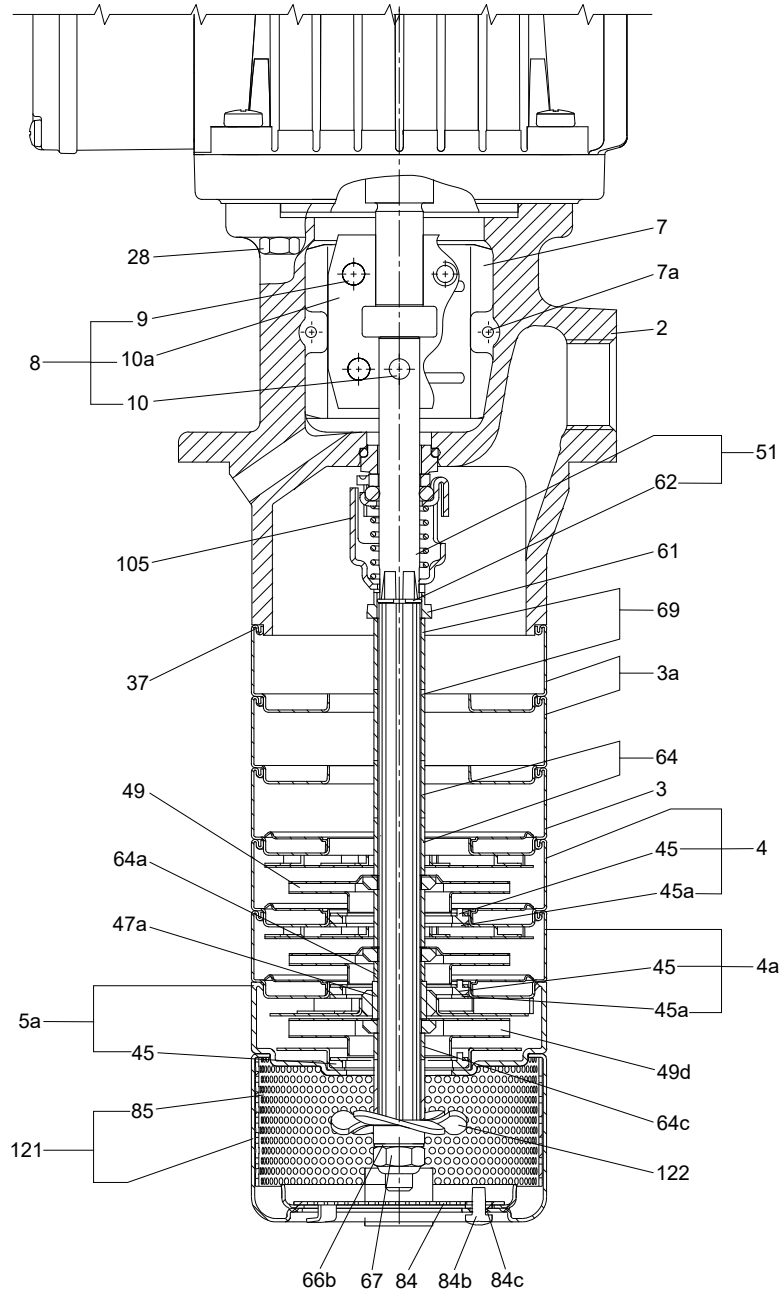

TM019281

SPK 1, 2, 4

Related information

[SPK materials](#)

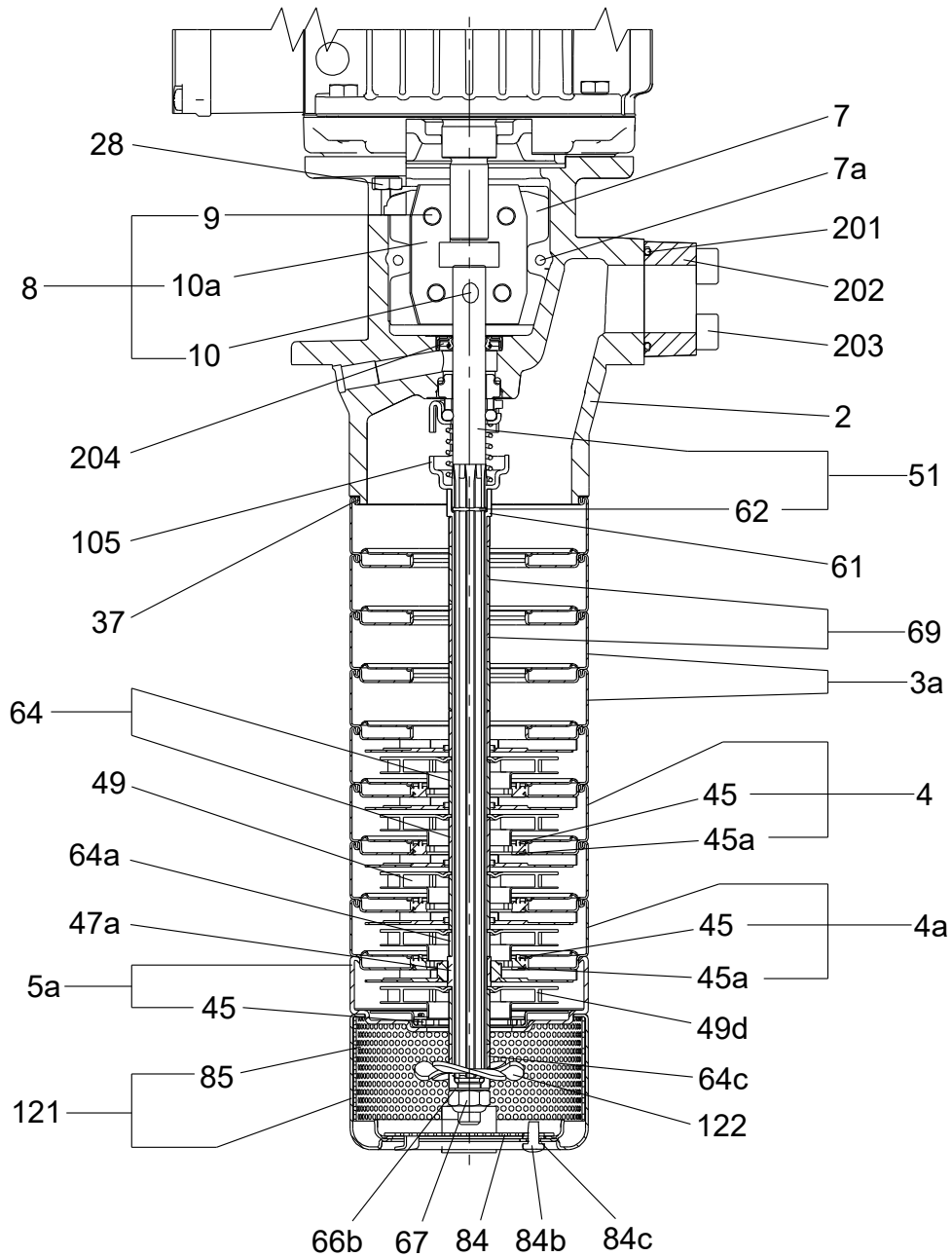
SPK 1, 2, 4 with drainage back to the tank**Sectional drawing**

SPK 1, 2, 4 with drainage back to the tank

Related information

[SPK materials](#)

TM1040167

SPK materials

Pos.	Description	Materials	EN/DIN	AISI/ASTM
Pump head				
2	Pump head	A-version: cast iron	EN-GJL-200	ASTM 25B
		I-version: stainless steel	1.4408	AISI 316LN
7	Coupling guard	Stainless steel	1.4301	AISI 304
7a	Screw	Stainless steel		
28	Set screw	Stainless steel		
	Extension pipe	Stainless steel	1.4301	AISI 304
Chamber without bearing				
3	Chamber, empty	Stainless steel	1.4301	AISI 304
3a	Chamber, empty	Stainless steel	1.4301	AISI 304
4	Chamber	Stainless steel	1.4301	AISI 304
45	Neck ring	PPS with 40 % glass fibre		
		Tin/bronze	2.1020.10	
45a	Disc for neck ring	PTFE		
64	Spacing pipe	Stainless steel	1.4401	AISI 316
69	Spacing pipe	Stainless steel	1.4401	AISI 316
Chamber with bearing				
4a	Chamber	Stainless steel	1.4301	AISI 304
	Bearing in chamber	Ceramic Al ₂ O ₃ 95-100 % Hilox™		
45	Neck ring	PPS with 40 % glass fibre		
		Tin/bronze	2.1020.10	
45a	Disc for neck ring	PTFE		
47a	Bearing ring	Tungsten carbide		
64a	Spacing pipe	Stainless steel	1.4401	AISI 316
64b	Spacing pipe	Stainless steel	1.4401	AISI 316
Bottom chamber				
5a	Chamber	Stainless steel	1.4301	AISI 304
45	Neck ring	PPS with 40 % glass fibre		
45a	Disc for neck ring	PTFE		
64c	Spacing pipe	Stainless steel	1.4401	AISI 316
Inlet part				
84	Inlet strainer	Stainless steel	1.4301	AISI 304
121	Inlet part	Stainless steel	1.4301	AISI 304
84b	Set screw	Stainless steel		
Shaft				
51	Spline shaft	Stainless steel	1.4057	AISI 431
61	Neck ring	Stainless steel	1.4301	AISI 304
62	Stop ring	Stainless steel	1.4436	AISI 316
64c	Neck ring	Stainless steel	1.4401	AISI 316
66	Washer	Stainless steel	1.4301	AISI 304
67	Locking nut	Stainless steel	1.4401	AISI 316
69a	Spacing pipe	Stainless steel	1.4301	AISI 304
112	Spacing pipe	Stainless steel	1.4301	AISI 304
122	Priming screw	Stainless steel	1.4401	AISI 316
201	O-ring	NBR		
202	Counterflange	Cast iron	EN-GJL-200	ASTM 25B
203	Bolt	Stainless steel		
204	Lip seal	FKM		
Impeller				
49	Impeller	Stainless steel	1.4301	AISI 304
49d	Impeller, lower	Stainless steel	1.4301	AISI 304
Strap				

Pos.	Description	Materials	EN/DIN	AISI/ASTM
26	Strap	Stainless steel	1.4301	AISI 304
36	Nut	Stainless steel		
66a	Washer	Stainless steel		
Coupling				
8	Coupling	Sintered metal		
9	Hexagon socket head screw	Steel		
10	Shaft pin	Stainless steel	1.4301	AISI 304

Construction of MTH pumps

MTH 2, 4, 8

Sectional drawing

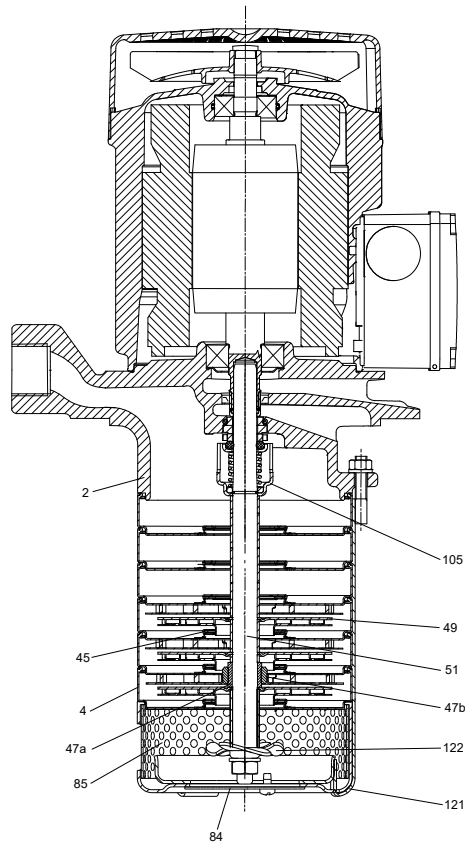

TM062773

MTH 2, 4, 8

Materials

Pos.	Description	Materials	EN/DIN	AISI/ASTM
2	Pump head	A-version: cast iron	EN-GJL-200	ASTM 25B
		I-version: stainless steel	1.4408	AISI 316LN
4	Chamber	I-version: stainless steel	1.4301	AISI 304
45	Neck ring	PTFE	-	-
47a	Bearing ring	MTH 2: SiC EkasiC F	-	-
		MTH 4: AL 203-95-100 % (HILOX 961/3)	-	-
		MTH 8: Silicon carbide	-	-
47b	Bearing	MTH 2: SiC EkasiC P	-	-
		MTH 4: Tungsten carbide	-	-
		MTH 8: Silicon carbide	-	-
49	Impeller	Stainless steel	1.4301	AISI 304
51	Pump shaft	Stainless steel	1.4057	AISI 431
84	Inlet strainer	Stainless steel	1.4301	AISI 304
85	Strainer, internal	Stainless steel	1.4301	AISI 304
105	Shaft seal	AQQV	-	-
121	Strap	Stainless steel	1.4301	AISI 304
122	Priming screw	Stainless steel	1.4301	AISI 304

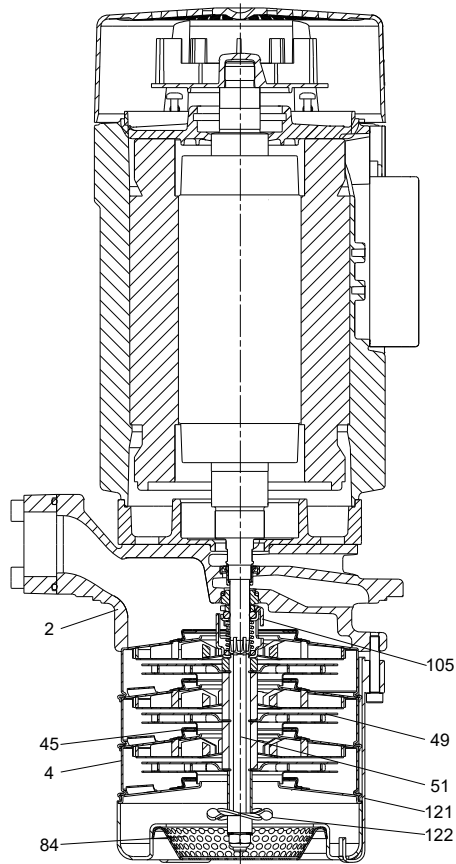
MTH 10, 15**Sectional drawing**

TM069651

MTH 10, 15**Materials**

Pos.	Description	A-version			I-version		
		Materials	EN/DIN	AISI/ASTM	Materials	EN/DIN	AISI/ASTM
2	Pump head	Cast iron	EN-GJL-200	ASTM 25B	Stainless steel	1.4408	CF8M
4	Chamber	Stainless steel	1.4301	AISI 304	Stainless steel	1.4301	AISI 304
45	Neck ring	PTFE	-	-	PTFE	-	-
49	Impeller	Stainless steel	1.4301	AISI 304	Stainless steel	1.4301	AISI 304
51	Pump shaft	Stainless steel	1.4057	AISI 431	Stainless steel	1.4057	AISI 431
84	Inlet strainer	Stainless steel	1.4301	AISI 304	Stainless steel	1.4301	AISI 304
105	Shaft seal	AQQV	-	-	AQQV	-	-
121	Strap	Stainless steel	1.4301	AISI 304	Stainless steel	1.4301	AISI 304
122	Priming screw	Stainless steel	1.4301	AISI 304	Stainless steel	1.4301	AISI 304

Construction of MTA pumps

MTA 30, 60, 90, 20H, 40H, 70H

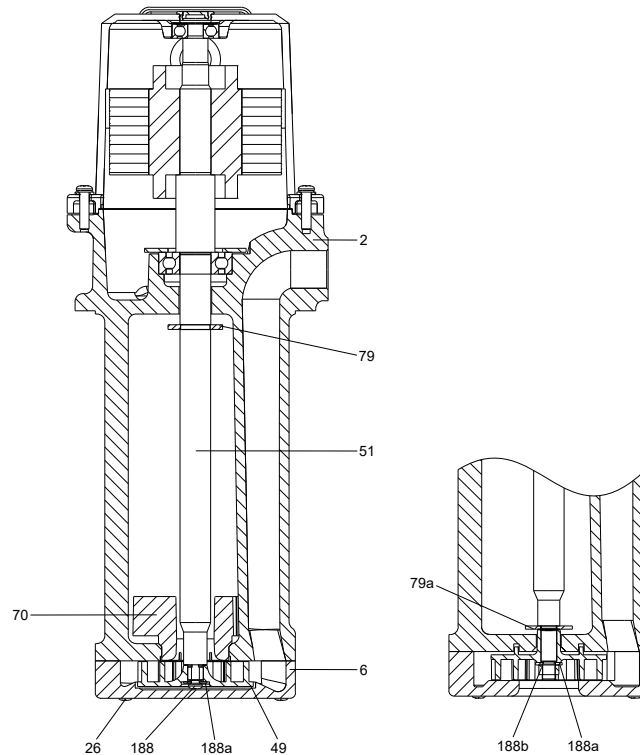

TM050894

Pos.	Description	Materials	EN/DIN	AISI/ASTM	JIS
2	Pump head	Cast iron	GG20	A48-CL30	FC200
6	Pump housing	Cast iron	GG20	A48-CL30	FC200
26	Screw	Stainless steel	1.4301	A276-304	SUS304
49	Impeller	MTA 30, 60, 90, 70H ⁶⁾	PAA GF50	-	-
		MTA 20H, 40H, 70H ⁷⁾	Bronze casting	G-CuZn-5ZnPb	C92200
51	Shaft with rotor	Steel	C45	A108-1045	S45C
70	Vortex preventer	MTA 90	PP	-	-
79	Thrower	NBR	-	-	-
79a	Splash ring	Steel	1623 ST 12	A366	SPCC
188	Cross-head screw	Stainless steel	1.4301	A276-304	SUS304
188a	Washer	Stainless steel	1.4301	A276-304	SUS304
188b	Hexagon nut	Stainless steel	1.4301	A276-304	SUS304
-	Terminal box	Aluminium	-	-	-

⁶⁾ MTA 70H, bottom inlet.

⁷⁾ MTA 70H, top inlet.

MTA 120, 200, 100H

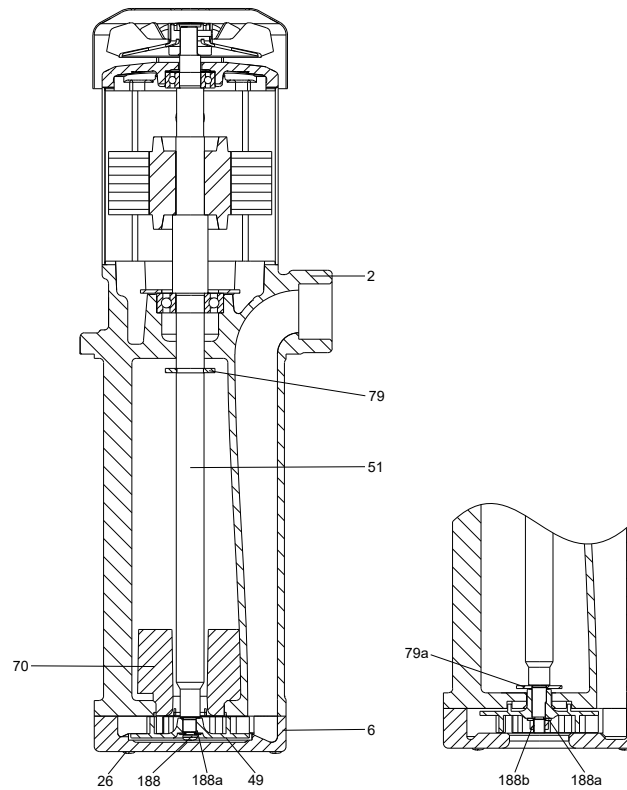

TM050895

Pos.	Description	Materials	EN/DIN	AISI/ASTM	JIS
2	Pump head	Cast iron	GG20	A48-CL30	FC200
6	Pump housing	Cast iron	GG20	A48-CL30	FC200
26	Screw	Stainless steel	1.4301	A276-304	SUS304
49	Impeller	Bronze casting	G-CuZn-5ZnPb	C92200	BC7
		MTA 120	PAA GF 50	-	-
51	Shaft with rotor	Steel	C45	A108-1045	S45C
70	Vortex preventer	MTA 120	PP	-	-
79	Thrower	NBR	-	-	-
79a	Splash ring	Steel	1623 ST 12	A366	SPCC
188	Cross-head screw	Stainless steel	1.4301	A276-304	SUS304
188a	Washer	Stainless steel	1.4301	A276-304	SUS304
188b	Hexagon nut	Stainless steel	1.4301	A276-304	SUS304
-	Terminal box	Aluminium	-	-	-

9. Identification

Type keys for MTR, SPK, MTH

Type key for MTR, MTRE

Example of a pump type key.

MTRE 32-2/1-1 A-F-A-HUUU

Code	Explanation
MTR	Pump type
E	Pump with integrated frequency converter
32	Rated flow rate [m ³ /h]
2	Number of chambers
1	Number of impellers
1	Number of impellers with reduced diameter
A	Code for pump version
F	Code for pipe connection
A	Code for materials
Code for shaft seal:	
H	• Shaft seal type designation
U	• Seal face material (rotating seal face)
U	• Seal face material (stationary seal face)
V	• Secondary seal material (rubber parts)

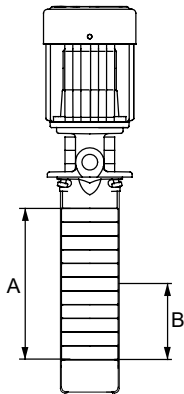

Number of chambers (A) and number of impellers (B)

Type key for SPK

Example of pump a type key.

SPKE 2-15/8 A-W-A-AUUU

Code	Explanation
SPK	Pump type
E	Pump with integrated frequency converter
2	Rated flow rate [m ³ /h]
15	Number of chambers
8	Number of impellers
A	Code for pump version
W	Code for pipe connection
A	Code for materials
Code for shaft seal:	

Code	Explanation
A	• Shaft seal type designation
U	• Seal face material (rotating seal face)
U	• Seal face material (stationary seal face)
V	• Secondary seal material (rubber parts)

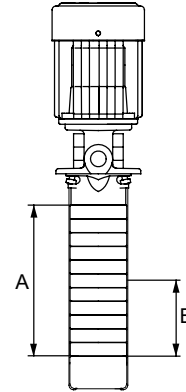

Number of chambers (A) and number of impellers (B)

Type key for MTH

Example of a pump type key.

MTH 2-6/3 A-W-A-AUUU

Code	Explanation
MTH	Pump type
2	Rated flow rate [m ³ /h]
6	Number of chambers
3	Number of impellers
A	Code for pump version
W	Code for pipe connection
A	Code for materials
Code for shaft seal:	
A	• Shaft seal type designation
U	• Seal face material (rotating seal face)
U	• Seal face material (stationary seal face)
V	• Secondary seal material (rubber parts)

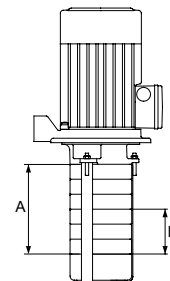

Number of chambers (A) and number of impellers (B)

Key to codes

Note that each individual pump type is not available in all variants.

Code	Description
Pump version	
A	Basic version
B	Oversize motor
C	Inlet pipe
D	Drainage back to tank
E	Pump with certificate/approval
F	120 °C version
H	Horizontal version
HS	High pressure
J	E-pump with different maximum speed
L	With extension pipe
P	Undersize motor
T	Double oversize
X	Special version
Pipe connection	
F	DIN flange
G	ANSI flange
J	JIS flange
W	Internal thread
WB	NPT internal thread
X	Special version
Materials	
A	Basic version
I	Wetted parts EN/DIN 1.4301 / AISI 304
N	Wetted parts EN/DIN 1.4401 / AISI 316
X	Special version
Shaft seal type designation	
A	O-ring seal with fixed seal driver
B	Bellows seal, rubber
C	O-ring seal with spring as seal driver
H	Balanced cartridge seal with O-ring
R	O-ring seal, type A, with reduced seal faces
Seal face material (rotating and stationary seal face)	
A	Carbon, metal-impregnated
B	Carbon, synthetic resin-impregnated
Q	Silicon carbide
U	Cemented tungsten carbide
V	Metal oxides, ceramic
Secondary seal material (rubber parts)	
E	EPDM
F	FXM (Fluoraz®)
K	FFKM (Kalrez®)
P	NBR
V	FKM (Viton®)

Type key for MTA

Example of a pump type key.

MTA 30 H-150 A-W-A-T

Code	Explanation
MTA	Pump type
30	Pump size
H	Pressure type
150	Installation length [mm]
A	Code for pump version
W	Code for pipe connection
A	Impeller material
T	Inlet

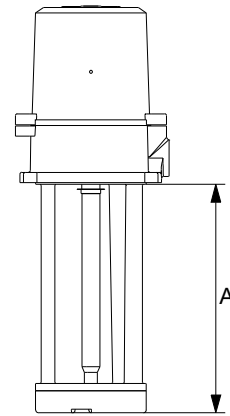

TM051021

Installation length (A)

Key to codes

Note that each individual pump type is not available in all variants.

Code	Description
Pump version	
A	Basic version
Pipe connection	
W	Internal thread
WB	NPT internal thread
Impeller material	
A	PAA GF50
B	Bronze
Inlet	
T	Top
B	Bottom

10. Installation

Installation of MTR, MTRE pumps

MTR, MTRE 1s, 1, 2, 3, 4, 5, 8, 10, 15 and 20 pumps can be installed both vertically and horizontally. For further information, see the section on horizontal mounting.

MTR, MTRE 32, 45, 64 pumps must be installed in a vertical position.

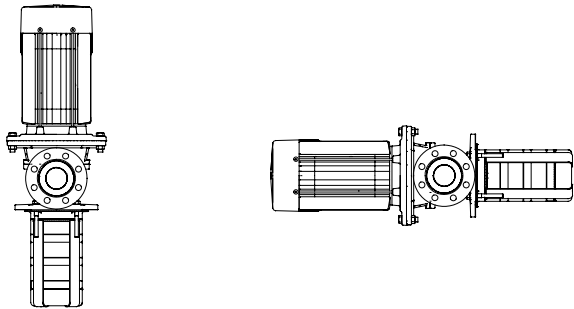

Installation of an MTR, MTRE pump. Left: vertical. Right: horizontal

Related information

[Horizontal mounting](#)

Inlet conditions

The bottom of the pump strainer must be at least 25 mm above the bottom of the tank.

The pumps are designed to provide full performance down to a level of A mm above the bottom of the strainer.

At a liquid level between A and B mm above the bottom of the strainer, the built-in priming screw protects the pump against dry running.

MTR 32, 45 and 64 pumps have no priming screw.

Pump type	A [mm]	B [mm]
MTR 1s, 1, 2, 3, 4, 5, 8	41	28
MTR 10, 15, 20	50	25
MTR 32, 45, 64	70	-

The distance between the flange and the liquid level must be minimum 25 mm.

The distance between the pump and the tank bottom must be minimum 25 mm.

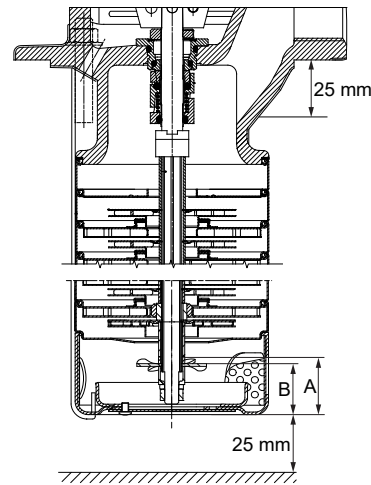

MTR 1s, 1, 2, 3, 4, 5, 8

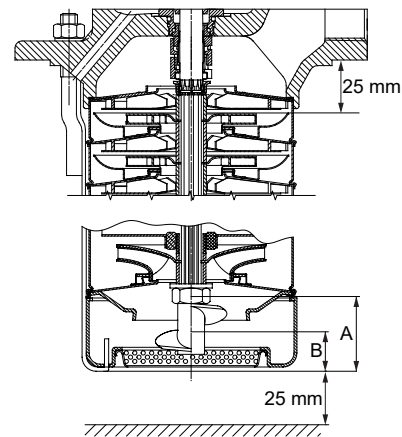

MTR 10, 15, 20

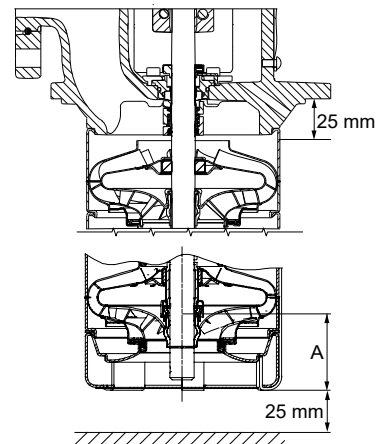

MTR 32, 45, 64

TM072800

TM059087

TM059085

Installation of SPK pumps

SPK pumps can be installed both vertically and horizontally. If the SPK pump is installed horizontally, the drain hole in the pump head must be closed. For further information, see the section on horizontal mounting.

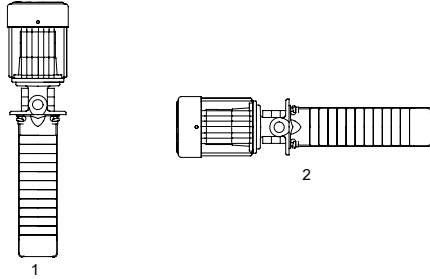

Installation of an SPK pump. 1: vertical. 2: horizontal

To enable a very low liquid level of 40 mm above the bottom of the inlet strainer, a priming screw is fitted below the bottom chamber. This protects the pump against dry running down to 25 mm above the bottom of the inlet strainer.

The distance between the flange and the liquid level must be minimum 25 mm.

The distance between the pump and the tank bottom must be minimum 25 mm.

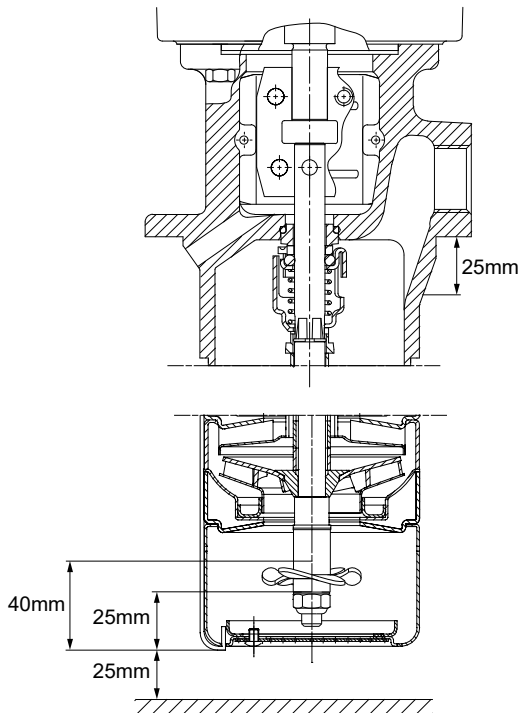

TM001922

TM011204

Installation of MTH pumps

MTH pumps must be installed vertically.

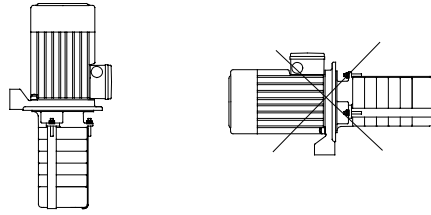

Installation of an MTH pump. Left: vertical. Right: horizontal

To enable a low liquid level of 40 mm above the bottom of the inlet strainer, a priming screw is fitted below the bottom chamber. This protects the pump against dry running down to 25 mm above the bottom of the inlet strainer.

The distance between the flange and the liquid level must be minimum 25 mm.

The distance between the pump and the tank bottom must be minimum 25 mm.

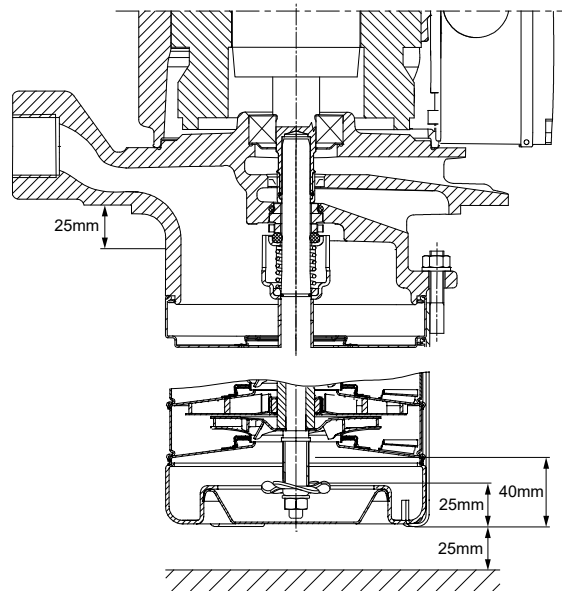

TM001923

TM017809

Installation of MTA pumps

MTA pumps are designed for vertical installation in a tank.

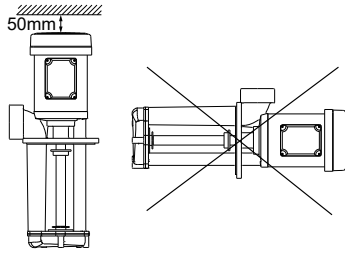

TM1040216

Installation of an MTA pump. Left: vertical. Right: horizontal

Provide a clearance of minimum 50 mm above the motor to ensure cooling of fan-cooled motors (MTA 120, 200 and 100H).

The pump is designed for indoor operation only.

Note that the motor must not be exposed to direct water/liquid sprays.

Liquid level

MTA with top inlet

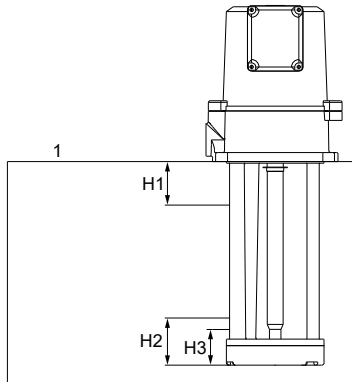

TM047992

MTA with top inlet

Pos.	Description
1	Tank
H1	Maximum liquid level
H2	Minimum liquid level (full performance)
H3	Minimum permissible liquid level (reduced performance)

Pump	H1 [mm]	H2 [mm]	H3 [mm]
MTA 30	15	60	50
MTA 60	20	70	45
MTA 90	20	85	58
MTA 120	20	110	70
MTA 20H	15	50	40
MTA 40H	20	70	40
MTA 70H	20	80	50
MTA 100H	20	110	60

MTA with bottom inlet

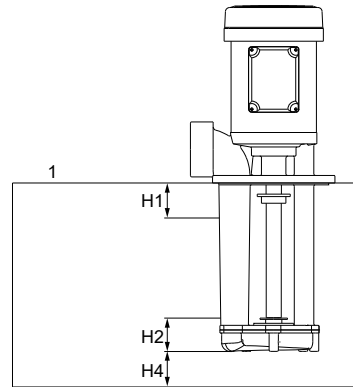

TM047993

MTA with bottom inlet

Pos.	Description
1	Tank
H1	Maximum liquid level
H2	Minimum liquid level (full performance)
H4	Minimum liquid level

Pump	H1 [mm]	H2 [mm]	H4 [mm]
MTA 30	15	20	10
MTA 60	20	20	10
MTA 90	20	25	15
MTA 120	20	25	20
MTA 200	25	50	30

Electrical installation

Electrical installation

MTR, SPK and MTH pumps can be fitted with a 10-pin multiplug connection, type Han® 10 ES.

The purpose of a multiplug connection is to make the electrical installation and the service of the pump easier. The multiplug functions as a plug-and-pump device.

The following drawings show where the multiplug is positioned on the motor.

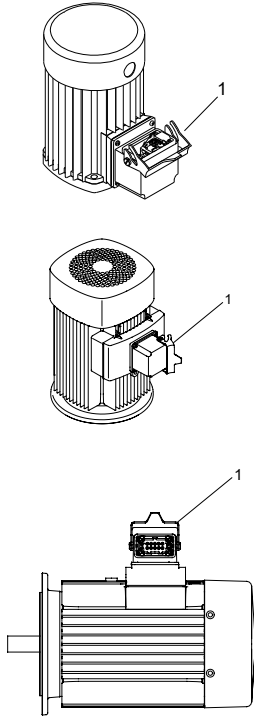

Multiplug connection type Han® 10 ES on a Grundfos MG motor (1)

On request, the following motors can be supplied with a multiplug connection (type Han® 10 ES):

- motors for MTR/SPK up to 7.5 kW
- all MTH motors.

Technical data for multiplug

Material description

Material	Description
Material	GD-Al Si 8 Cu 3
Surface	Powder paint
Clip for locking	Stainless steel
Housing gasket	NBR rubber
Temperature range [°C]	-40 to +125
Enclosure class	IP65 at DIN 40050 in closed position
Type	Han® 10E

Dimensions

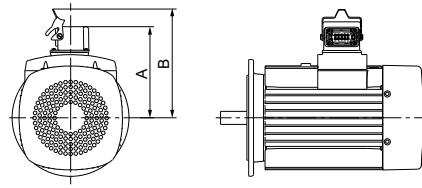

TM045756

Motor with multiplug

Motor	Frame size	A [mm]	B [mm]
MG	71	131	162
MG	80	131	162
MG	90	173	204
MG	100	183	214
MG	112	197	228
MG (5.5 kW)	132	197	228
MG (7.5 kW)	132	222	253

TM056900

TM018713

TM028518

Plug connections

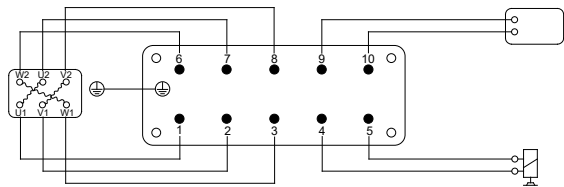

TM018702

From motor

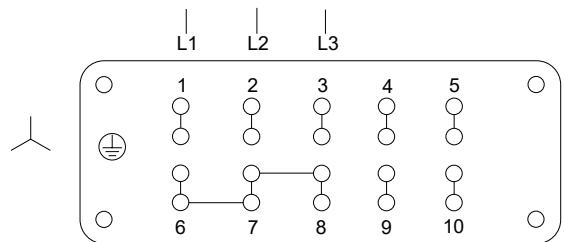

TM018703

Plug connections for star connection

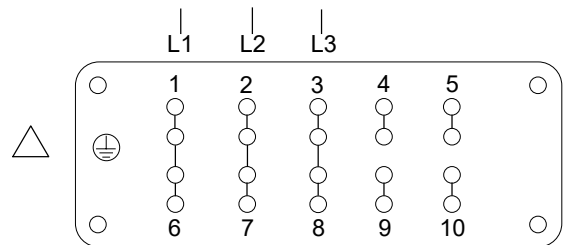

TM018704

Plug connections for delta connection. Fishplates for connections are located in the plug.

11. Selection and sizing

Selection of pumps

Selection of pumps must be based on the following parameters:

- the duty point of the pump
- dimensional data such as pressure loss as a result of height differences, friction loss in the pipes, pump efficiency
- minimum inlet pressure - NPSH.

Duty point of the pump

From a duty point you can select a pump on the basis of the curve charts shown in the section on performance curves and technical data.

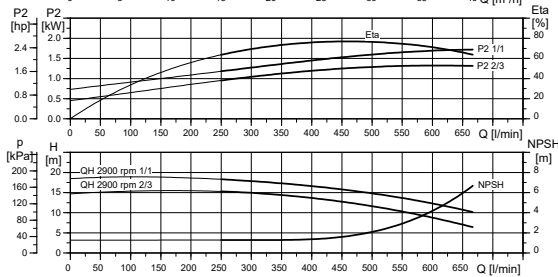
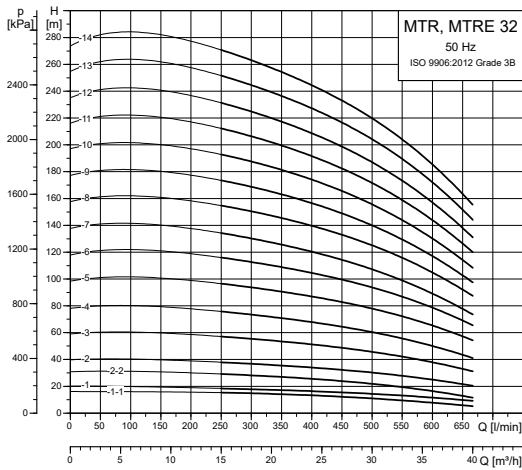

Example of a curve chart

Related information

[How to read the curve charts](#)

Sizing data

When sizing a pump the following aspects must be taken into account:

- required flow rate and pressure at the draw-off point
- pressure loss as a result of height differences (H_{geo})
- friction loss in the pipes (H_f). It may be necessary to account for pressure loss in connection with, for example, long pipes, bends or valves.
- best efficiency at the estimated duty point
- NPSH value. For calculation of the NPSH value, see the section on minimum inlet pressure - NPSH.

Efficiency

Before determining the point of best efficiency, you need to identify the operating pattern of the pump.

If the pump is expected always to operate in the same duty point, select a pump which is operating at a duty point corresponding to the best efficiency of the pump.

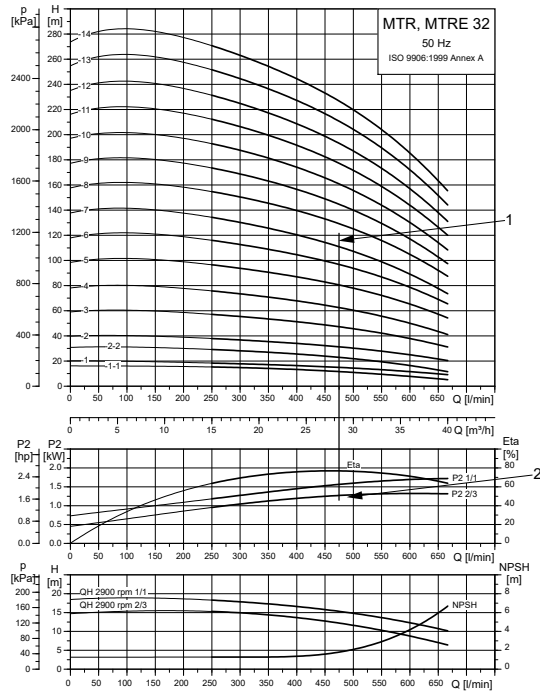

Example of a pump's duty point

Pos.	Description
1	Duty point
2	Best efficiency

As the pump is sized on the basis of the highest possible flow rate, it is important always to have the duty point to the right on the efficiency curve (eta) in order to keep efficiency high when the flow rate drops.

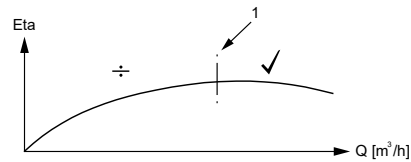

Best efficiency (1)

TM014302

TM079051

TM009190

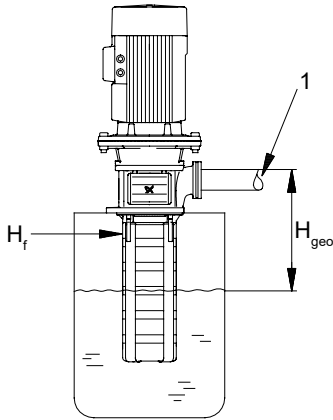

TM027531

Dimensional data

Pos.	Description
1	Required flow rate, required pressure

Normally, MTRE pumps are used in applications characterized by a variable flow rate. Consequently, you cannot select a pump that is operating constantly at optimum efficiency. To achieve optimum operating economy, you must select the pump on the basis of the following criteria:

- The maximum duty point must be as close as possible to the QH curve of the pump.
- The required duty point must be positioned so that P2 is close to the maximum point of the QH curve.

Between the minimum and maximum performance curves, MTRE pumps have an infinite number of performance curves each representing a specific speed. Therefore, you may not be able to select a duty point close to the maximum curve.

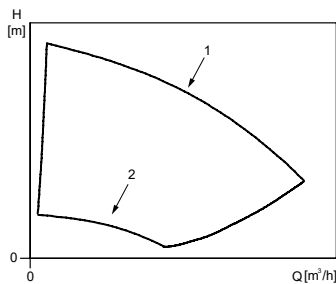

TM014916

Minimum and maximum performance curves

Pos.	Description
1	Maximum curve
2	Minimum curve

Affinity equations

In situations where you cannot select a duty point close to the maximum curve, you can use the affinity equations below. The head (H), the flow rate (Q) and the input power (P) are all the appropriate variables you need to be able to calculate the motor speed (n).

The approximated formulas apply on condition that the system characteristic remains unchanged for n_n and n_x and that it is based on the formula $H = k \times Q^2$ where k is a constant.

The power equation implies that the pump efficiency is unchanged at the two speeds. In practice this is not quite correct.

Finally, the efficiencies of the frequency converter and the motor must be taken into account if you want a precise calculation of the power saving resulting from a reduction of the pump speed.

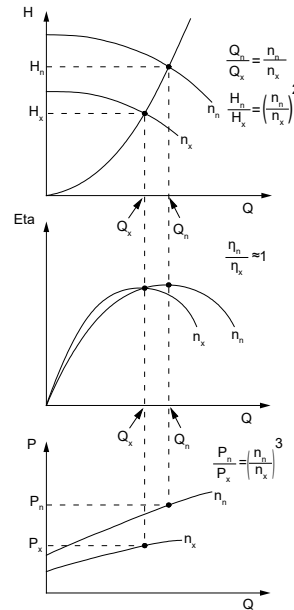

TM008720

Affinity equations

Legend

H_n	Rated head [m]
H_x	Current head [m]
Q_n	Flow rate [m³/h]
Q_x	Current flow rate [m³/h]
n_n	Rated motor speed [min ⁻¹]
n_x	Current motor speed [min ⁻¹]
η_n	Rated efficiency [%]
η_x	Current efficiency [%]

Grundfos Product Center

The Grundfos Product Center is an online product selection and sizing tool which you can use to calculate the specific duty point and energy consumption of the pump.

For further information, see the section in Grundfos Product Center.

Pressure loss

During operation pressure losses occur in all centrifugal pumps.

The below curves illustrate the pressure losses for pumped liquid passing through one empty chamber. An empty chamber is a chamber without an impeller.

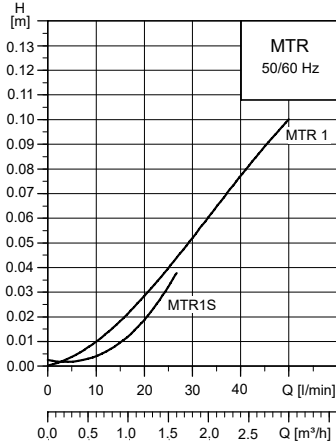

Pressure losses of pumped liquid passing through an empty chamber for MTR 1s and MTR 1 pumps

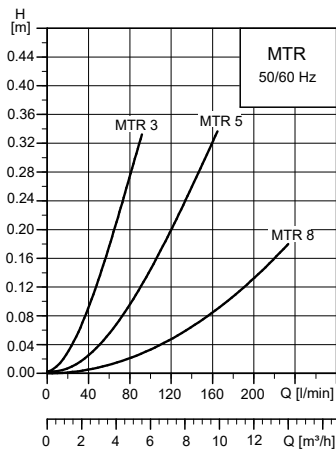

Pressure losses of pumped liquid passing through an empty chamber for MTR 3, MTR 5 and MTR 8 pumps

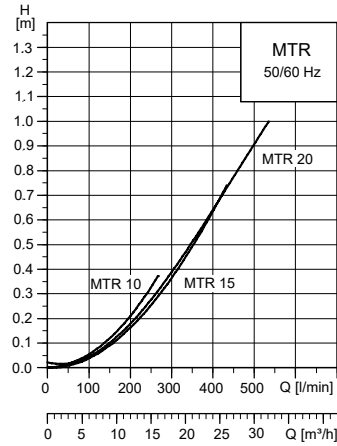

Pressure losses of pumped liquid passing through an empty chamber for MTR 10, MTR 15 and MTR 20 pumps

As MTR, MTRE 32, 45 and 64 pumps have holes in the guide vanes, no pressure losses occur in the empty chambers of these pumps.

Calculation of the reduced head of a pump and pressure loss in empty chambers

By combining the pressure loss curves and the performance curves for each pump type, you can calculate the reduced head of a pump with empty chambers.

You can do the calculation as shown below.

Example:

Pump type	MTR 5-18/7
Flow rate Q (duty point)	6 [m ³ /h]
Head (duty point)	90 [m]

The selected pump is an MTR 5-18/7 with 11 empty chambers. See type keys in the section on the MTR, MTRE type key.

From the above pressure loss curve of MTR 5, it appears that the pressure loss of each empty chamber at 6 m³/h is 0.14 [m]. This results in the following total pressure loss:

$$(Total\ pressure\ loss) = 0.14 \times 11 = 1.54 [m]$$

The reduced head of the MTR 5-18/7 pump including pressure losses caused by empty chambers is:

$$Head = 33 - 1.54 = 31.46 [m]$$

The head 33 metres is read from the performance curve for an MTR 5-18/7. See the section on MTR, MTRE 5, 50 Hz.

Related information

[MTR, MTRE 5, 50 Hz](#)

TM028546

TM028547

TM028581

Viscosity

Pump	Maximum kinematic viscosity of pumped liquid [cSt] = [mm ² /s]
MTR 1s, 1, 3, 5, 8	50
MTR 10, 15, 20, 32, 45, 64	100
SPK	50
MTH	50
MTA	75

Pumping liquids with densities or kinematic viscosities higher than those of water will cause a considerable pressure drop, a drop in the hydraulic performance and a rise in the power consumption.

In such situations you must equip the pump with a larger motor. If in doubt, contact Grundfos.

For further information about pump performance when pumping liquids with densities or kinematic viscosities higher than those of water, see Grundfos Product Center at <http://product-selection.grundfos.com/>.

Related information

[16. Grundfos Product Center](#)

Minimum inlet pressure, NPSH

We recommend that you calculate the inlet pressure "H" when the following aspects apply:

- The liquid temperature is high.
- The flow is significantly higher than the flow rate.
- Water is drawn from depths.
- Water is drawn through long pipes.
- Inlet conditions are poor.

To avoid cavitation, make sure that there is a minimum pressure on the inlet side of the pump. You can calculate the maximum suction lift "H" in metres head as follows:

$$H = \text{NPSH} + H_v + H_s - p_b \times 10.2$$

p_b	=	Barometric pressure in bar. You can set the barometric pressure to 1 bar. In closed systems, p_b indicates the system pressure in bar.
NPSH	=	Net Positive Suction Head in metres head. To be read from the NPSH curve at the highest flow rate the pump will be delivering.
H_v	=	Vapour pressure in metres head.
H_s	=	Safety margin = minimum 0.5 metre head.

If the calculated "H" is positive, the value shows how high the liquid level must be as minimum above the inlet strainer.

If the "H" calculated is negative, the value shows how deep the pump is able to suck in theory.

However, you have to fulfil the requirements of the minimum liquid level above the inlet strainer. See the section on installation of MTR, MTRE pumps.

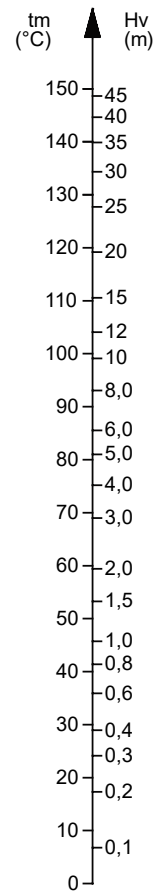
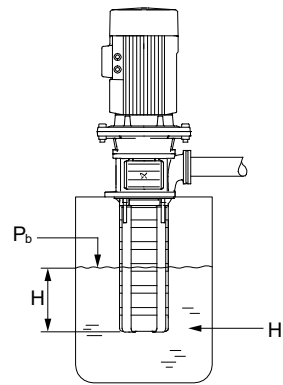

Minimum inlet pressure - NPSH

To avoid cavitation, never select a pump whose duty point is too far to the right on the NPSH curve.

Always check the NPSH value of the pump at the highest possible flow rate.

Related information

[Installation of MTR, MTRE pumps](#)

Pumped liquids

The pumps are designed to pump non-explosive liquids that do not chemically attack the pump materials.

When pumping liquids with a density and/or viscosity higher than that of water, oversized motors may be required.

Whether a pump is suitable for a particular liquid depends on several factors of which the most important are the chloride content, pH-value, temperature and content of chemicals and oils.

Please note that aggressive liquids may attack or dissolve the protective oxide film of the stainless steel and thus cause corrosion.

Pumping of solid particles

MTR, SPK and MTH pumps

These pumps are fitted with an inlet strainer. The strainer prevents large solid particles from entering and damaging the pump. The table below describes the size of the passage in the strainer and the impeller.

Pump	Strainer passage [mm]	Free strainer passage [cm ²]	Impeller passage [mm]
MTR(E) 1s	Ø2	23	2.5
MTR(E) 1	Ø2	23	2.5
MTR(E) 3	Ø2	23	3.1
MTR(E) 5	Ø4	28	5.5
MTR(E) 8	Ø4	28	5.5
MTR(E) 10	Ø4	43	5.5
MTR(E) 15	Ø4	43	6.0
MTR(E) 20	Ø4	43	8.0
MTR(E) 32	Ø4	56	8.0
MTR(E) 45	Ø4	56	9.5
MTR(E) 64	Ø4	56	13.0
SPK 1	Ø2	-	2.5
SPK 2	Ø2	-	2.5
SPK 4	Ø2	-	2.5
SPK 8	Ø4	-	4.0
MTH 2	Ø2	23	2.0
MTH 4	Ø4	28	4.0
MTH 8	Ø4	28	5.5
MTH 10	Ø4	43	5.5
MTH 15	Ø4	43	5.5

If the pumped liquid contains solid particles larger than the size of the holes in the strainer, the strainer passage may be blocked. In such situations the performance will drop because of a reduced pump flow.

Note that if you remove the strainer from the inlet port, solid particles may enter the pump and cause a seizure or even damage the pump.

In grinding applications Grundfos recommends that the pumped liquid is screened for abrasive particles before entering the pump. When pumped, abrasive particles reduce the life of the pump components.

Wear of the pump components caused by abrasive particles starts when the concentration exceeds 20 ppm.

MTA pumps

MTA pumps are not fitted with an inlet strainer.

Pump	Max. particle size [mm]
MTA 30	4-5
MTA 60	
MTA 90	
MTA 120	8-10
MTA 200	
MTA 20H	
MTA 40H	2-3
MTA 70H	
MTA 100H	

List of pumped liquids

A number of typical liquids are listed in the table below. Other pump versions or shaft seals may be applicable, but those stated in the list are considered to be the best choices.

The table is intended as a general guide only, and it cannot replace actual testing of the pumped liquids and pump materials under specific working conditions.

However, the list must be applied with some caution as factors such as concentration of the pumped liquid, liquid temperature or pressure may affect the chemical resistance of a specific pump version.

Safety precautions must be taken when pumping hazardous or flammable liquids.

Pumped liquid	Note	Liquid concentration, liquid temperature	Recommended pump version/shaft seal	
			MTR, MTRE	
			A-version (standard range, all wetted parts of cast iron and stainless steel)	I-version (stainless-steel version, all wetted parts of stainless steel EN/DIN 1.4301)
Acetic acid, CH ₃ COOH	-	5 %, 20 °C	-	HUUE
Alkaline degreasing agent	D, F	-	HUUE	-
Ammonium bicarbonate, NH ₄ HCO ₃	E	20 %, 30 °C	-	HUUE
Ammonium hydroxide, NH ₄ OH	-	20 %, 40 °C	HUUE	-
Benzoic acid, C ₆ H ₅ COOH	H	0.5 %, 20 °C	-	HUUV
Boiler water	-	< 90 °C	HUUE	-
Calcareous water	-	< 90 °C	HUUE	-
Calcium acetate (as coolant with inhibitor) Ca(CH ₃ COO) ₂	D, E	30 %, 50 °C	HUUE	-
Calcium hydroxide, Ca(OH) ₂	E	Saturated solution, 50 °C	HUUE	-
Chloride-containing water	F	< 30 °C, max. 500 ppm	-	HUUE
Citric acid, HOC(CH ₂ CO ₂ H) ₂ COOH	H	5 %, 40 °C	-	HUUE
Completely desalinated water (demineralised water)	-	< 90 °C	-	HUUE
Condensate	-	< 90 °C	HUUE	-
Copper sulphate, CuSO ₄	E	10 %, 30 °C	-	HUUE
Corn oil	D, E, 3	100 %, 80 °C	HUUV	-
Domestic hot water (potable water)	-	< 120 °C	HUUE	-
Ethylene glycol, HOCH ₂ CH ₂ OH	D, E	50 %, 50 °C	HUUE	-
Formic acid, HCOOH	-	2 %, 20 °C	-	HUUE
Glycerine (glycerol), OHCH ₂ CH(OH)CH ₂ OH	D, E	50 %, 50 °C	HUUE	-
Hydraulic oil (mineral)	E, 2, 3	100 %, 100 °C	HUUV	-
Hydraulic oil (synthetic)	E, 2, 3	100 %, 100 °C	HUUV	-
Lactic acid, CH ₃ CH(OH)COOH	E, H	10 %, 20 °C	-	HUUV
Linoleic acid, C ₁₇ H ₃₁ COOH	E, 3	100 %, 20 °C	HUUV	-
Motor oil	E, 2, 3	100 %, 80 °C	HUUV	-
Cutting oil	E	90 °C	HUUV	-
Water-based cooling lubricant	E	90 °C	HUUV	-
Naphthalene, C ₁₀ H ₈	E, H	100 %, 80 °C	HUUV	-
Nitric acid, HNO ₃	F	1 %, 20 °C	-	HUUE
Oil-containing water	-	< 90 °C	HUUV	-
Olive oil	D, E, 3	100 %, 80 °C	HUUV	-
Oxalic acid, (COOH) ₂	H	1 %, 20 °C	-	HUUE
Peanut oil	D, E, 3	100 %, 80 °C	HUUV	-
Phosphoric acid, H ₃ PO ₄	E	20 %, 20 °C	-	HUUE
Propylene glycol, CH ₃ CH(OH)CH ₂ OH	D, E	50 %, 90 °C	HUUE	-
Potassium carbonate, K ₂ CO ₃	E	20 %, 50 °C	HUUE	-
Potassium formate (as coolant with inhibitor), KOOCH	D, E	30 %, 50 °C	HUUE	-
Potassium hydroxide, KOH	E	20 %, 50 °C	-	HUUE
Potassium permanganate, KMnO ₄	-	1 %, 20 °C	-	HUUE
Rape seed oil	D, E, 3	100 %, 80 °C	HUUV	-

Pumped liquid	Note	Liquid concentration, liquid temperature	Recommended pump version/shaft seal	
			MTR, MTRE	
			A-version (standard range, all wetted parts of cast iron and stainless steel)	I-version (stainless-steel version, all wetted parts of stainless steel EN/DIN 1.4301)
Salicylic acid, C ₆ H ₄ (OH)COOH	H	0.1 %, 20 °C	-	HUUE
Silicone oil	E, 3	100 %	HUUV	-
Sodium bicarbonate, NaHCO ₃	E	10 %, 60 °C	-	HUUE
Sodium chloride (as coolant), NaCl	D, E	30 %, < 5 °C, pH > 8	HUUE	-
Sodium hydroxide, NaOH	E	20 %, 50 °C	-	HUUE
Sodium nitrate, NaNO ₃	E	10 %, 60 °C	-	HUUE
Sodium phosphate, Na ₃ PO ₄	E, H	10 %, 60 °C	-	HUUE
Sodium sulphate, Na ₂ SO ₄	E, H	10 %, 60 °C	-	HUUE
Softened water	-	< 120 °C	-	HUUE
Soya oil	D, E, 3	100 %, 80 °C	HUUV	-
Unsalted swimming pool water	-	Approx. 2 ppm free chlorine (Cl ₂)	HUUE	-

List of notes

D	Often with additives.
E	Density and/or viscosity differ from that of water. Allow for this when calculating motor output and pump performance.
F	Pump selection depends on many factors. Contact Grundfos.
H	Risk of crystallisation/precipitation in shaft seal.
1	The pumped liquid is easily ignited.
2	The pumped liquid highly flammable.
3	Insoluble in water.
4	Low self-ignition point.

12. Performance curves and technical data

Introduction to performance curves

How to read the curve charts

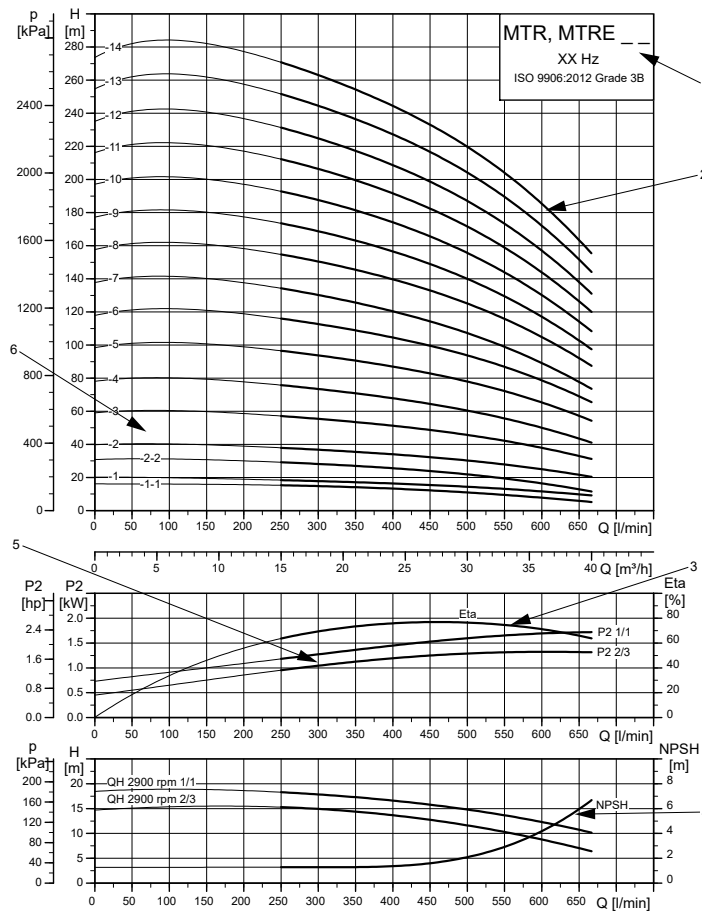

TM079052

Example of an MTR, MTRE curve chart

Pos.	Description
1	Pump type, frequency and ISO standard.
2	QH curve for the individual pump. The bold curves indicate the recommended performance range for best efficiency.
3	The eta curve shows the efficiency of the pump. The eta curve is an average curve of all the pump types shown in the chart.
4	The NPSH curve is a maximum curve for all the variants shown. When sizing the pumps, add a safety margin of at least 0.5 m.
5	The power curves indicate pump input power per stage. Curves are shown for complete (1/1) and reduced (2/3) impellers.
6	Number of stages. First figure: number of stages; second figure: number of reduced-diameter impellers.

Guidelines to performance curves

The guidelines below apply to the performance curves shown on the following pages:

1. Tolerances to ISO 9906:2012 Grade 3B, if indicated.
2. The motors used for the measurements are standard Grundfos motors (MG or MGE).
3. Measurements have been made with airless water at a temperature of 20 °C.
4. The curves apply to a kinematic viscosity of $\nu = 1 \text{ mm}^2/\text{s}$ (1 cSt).
5. Due to the risk of overheating, the pumps must not be used at a flow below the minimum flow rate.
6. QH curves of the individual pumps are based on current motor speeds.

The curve below shows the minimum flow rate as a percentage of the nominal flow rate in relation to the liquid temperature.

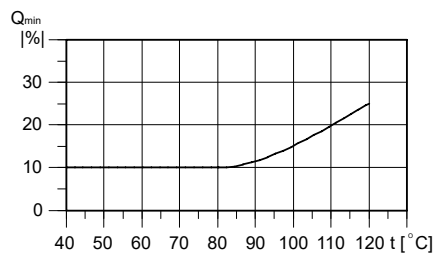

TM045693

Minimum flow rate

MTR, MTRE, 50 Hz

MTR, MTRE 1s, 50 Hz

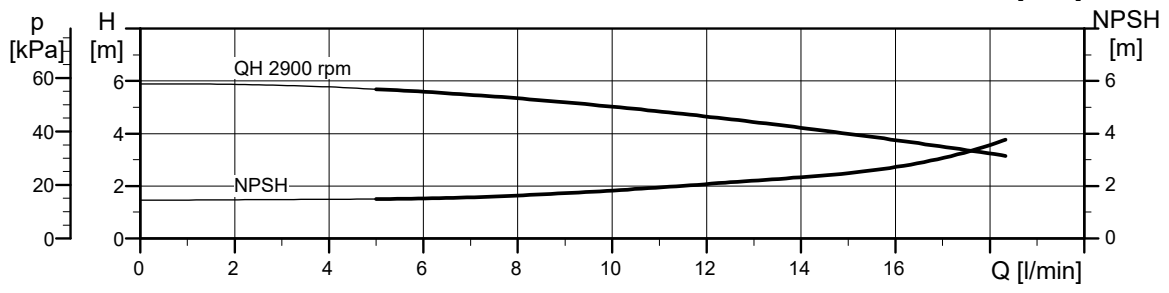
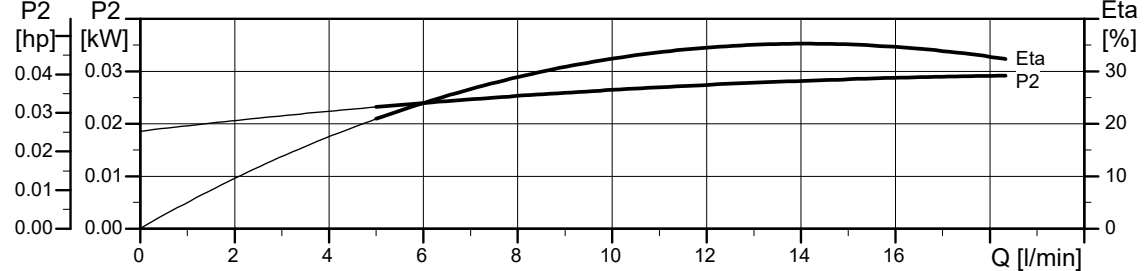
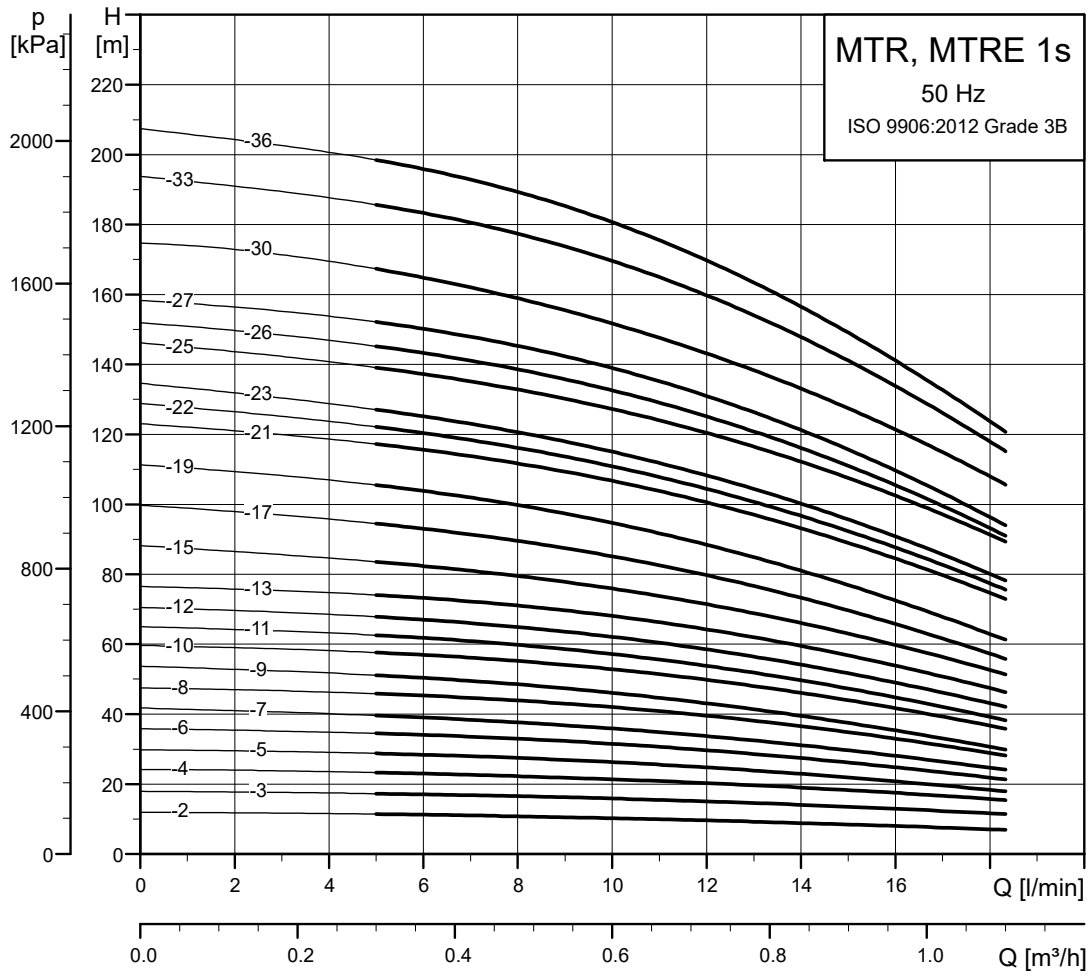

TM027839

Dimensional sketches

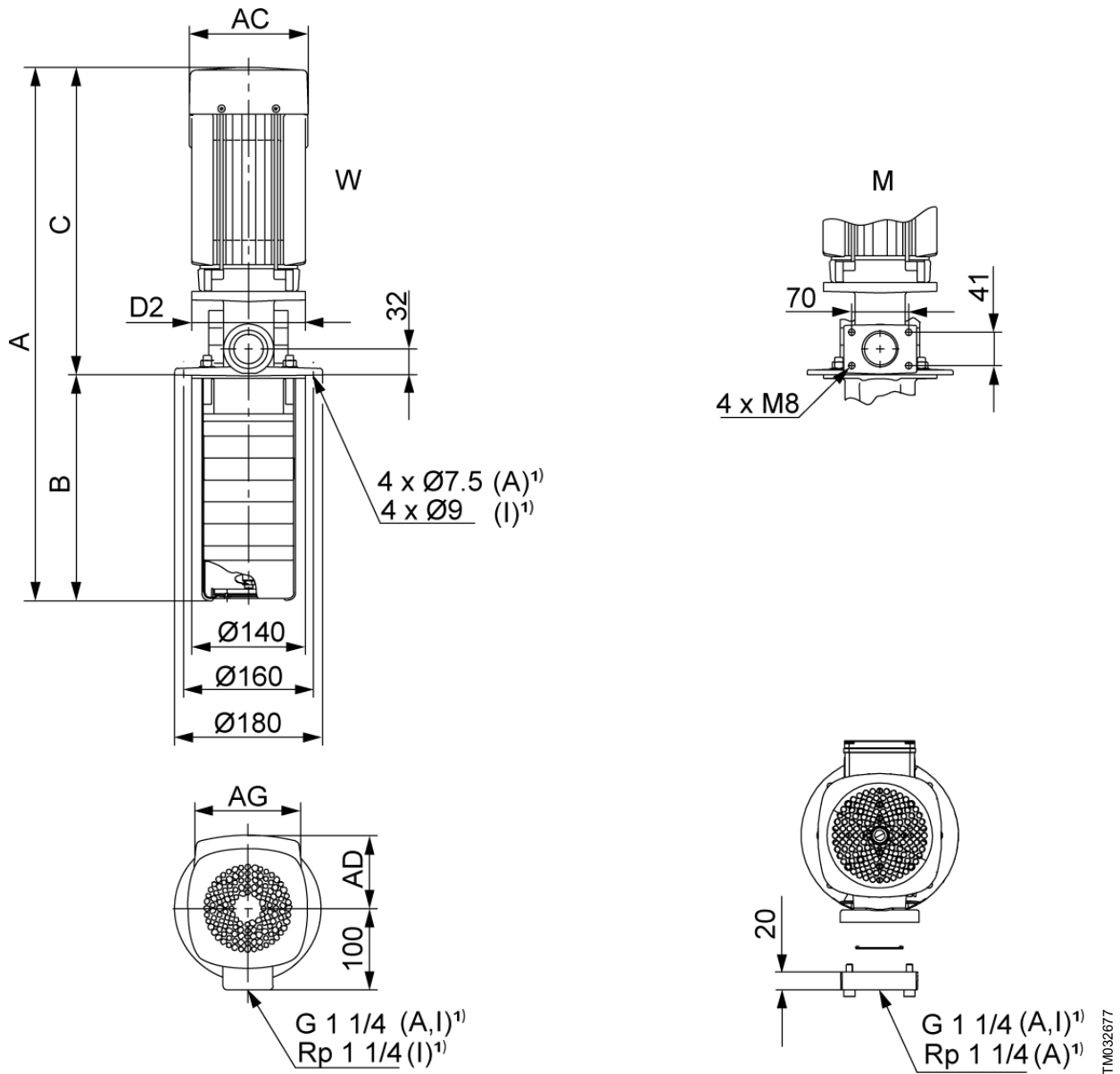

W: Internal thread connection. M: Square flange.

1) A: Basic version, cast iron. I: Stainless steel version.

Dimensions and weights

Pump type	P2 [kW]	MTR								Net weight [kg]	MTRE							Net weight [kg]
		Dimensions [mm]									Dimensions [mm]							
		A	B	C	AC	D2	AD	AG	A		B	C	AC	D2	AD	AG		
MTR 1s-2/2	0.37	462	160	302	141	140	109	82	12.9	-	-	-	-	-	-	-	-	-
MTR 1s-3/3	0.37	480	178	302	141	140	109	82	13	-	-	-	-	-	-	-	-	-
MTR 1s-4/4	0.37	498	196	302	141	140	109	82	13	-	-	-	-	-	-	-	-	-
MTR, MTRE 1s-5/5	0.37	516	214	302	141	140	109	82	13	579	214	365	122	140	158	268	17.4	
MTR 1s-6/6	0.37	534	232	302	141	140	109	82	13	-	-	-	-	-	-	-	-	-
MTR 1s-7/7	0.37	552	250	302	141	140	109	82	13.1	-	-	-	-	-	-	-	-	-
MTR, MTRE 1s-8/8	0.37	570	268	302	141	140	109	82	13.1	633	268	365	122	140	158	268	17.5	
MTR 1s-9/9	0.37	588	286	302	141	140	109	82	13.1	-	-	-	-	-	-	-	-	-
MTR 1s-10/10	0.37	606	304	302	141	140	109	82	13.1	-	-	-	-	-	-	-	-	-
MTR 1s-11/11	0.37	624	322	302	141	140	109	82	13.1	-	-	-	-	-	-	-	-	-

TM032677

Pump type	P2 [kW]	MTR							Net weight [kg]	MTRE							Net weight [kg]
		Dimensions [mm]								Dimensions [mm]							
		A	B	C	AC	D2	AD	AG		A	B	C	AC	D2	AD	AG	
MTR, MTRE 1s-12/12	0.37	642	340	302	141	140	109	82	13.2	705	340	365	122	140	158	268	17.6
MTR 1s-13/13	0.37	660	358	302	141	140	109	82	13.2	-	-	-	-	-	-	-	-
MTR 1s-15/15	0.55	696	394	302	141	140	109	82	12.7	-	-	-	-	-	-	-	-
MTR 1s-17/17	0.55	732	430	302	141	140	109	82	12.7	-	-	-	-	-	-	-	-
MTR, MTRE 1s-19/19	0.55	768	466	302	141	140	109	82	12.8	831	466	365	122	140	158	268	17.7
MTR 1s-21/21	0.75	844	502	342	141	140	109	82	15.1	-	-	-	-	-	-	-	-
MTR 1s-22/22	0.75	862	520	342	141	140	109	82	15.1	-	-	-	-	-	-	-	-
MTR 1s-23/23	0.75	880	538	342	141	140	109	82	15.2	-	-	-	-	-	-	-	-
MTR, MTRE 1s-25/25	0.75	916	574	342	141	140	109	82	15.2	939	574	365	122	140	158	268	17.9
MTR 1s-26/26	0.75	934	592	342	141	140	109	82	15.2	-	-	-	-	-	-	-	-
MTR 1s-27/27	1.1	972	610	362	141	140	109	82	17.2	-	-	-	-	-	-	-	-
MTR, MTRE 1s-30/30	1.1	1026	664	362	141	140	109	82	17.3	1029	664	365	122	140	158	268	18.8
MTR 1s-33/33	1.1	1080	718	362	141	140	109	82	17.4	-	-	-	-	-	-	-	-
MTR, MTRE 1s-36/36	1.1	1134	772	362	141	140	109	82	17.4	1137	772	365	122	140	158	268	18.9

The maximum immersion depth is 1006 mm.

MTR, MTRE 1, 50 Hz

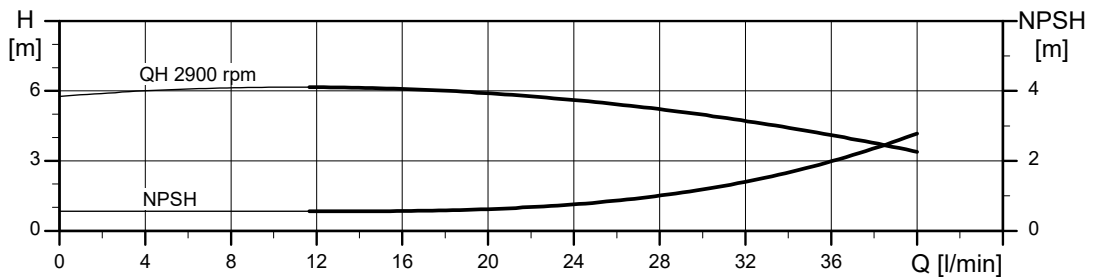
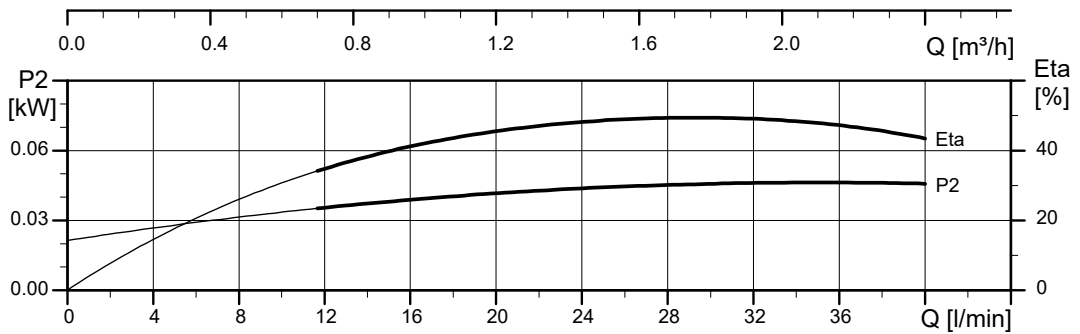
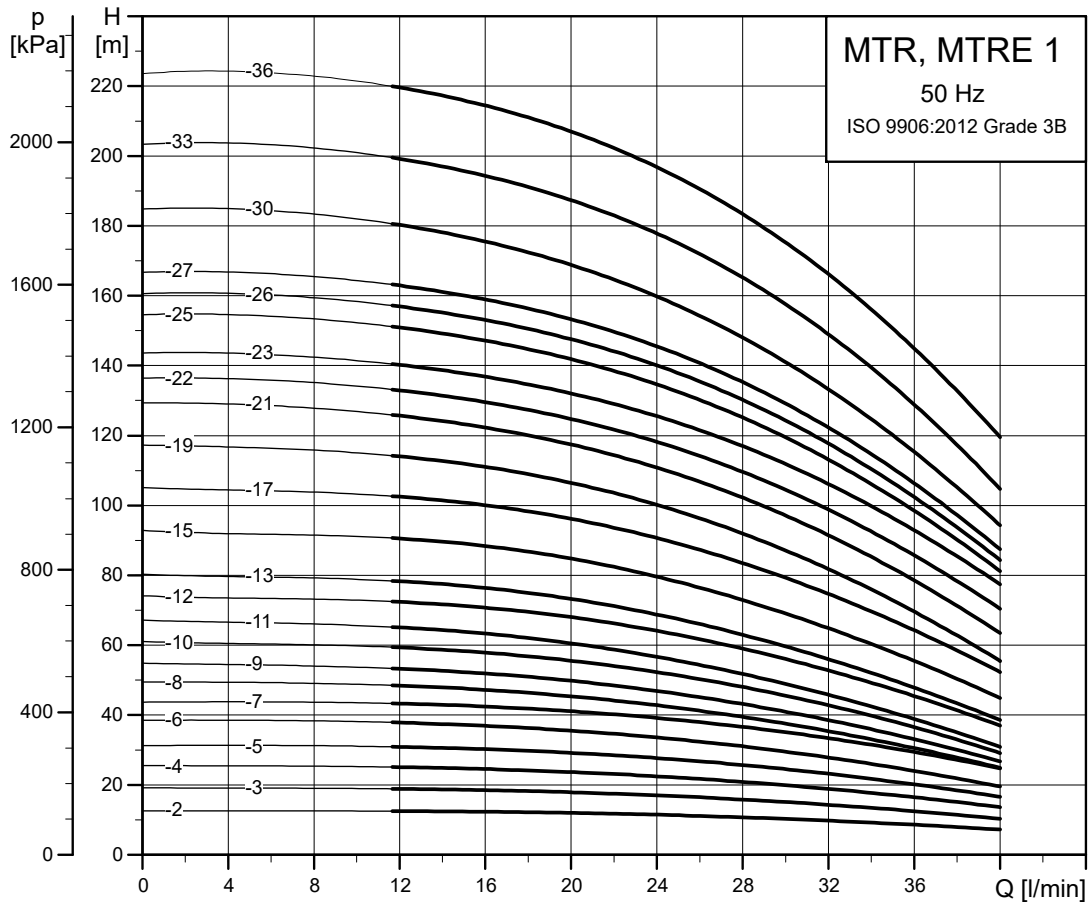

TM027840

Dimensional sketches

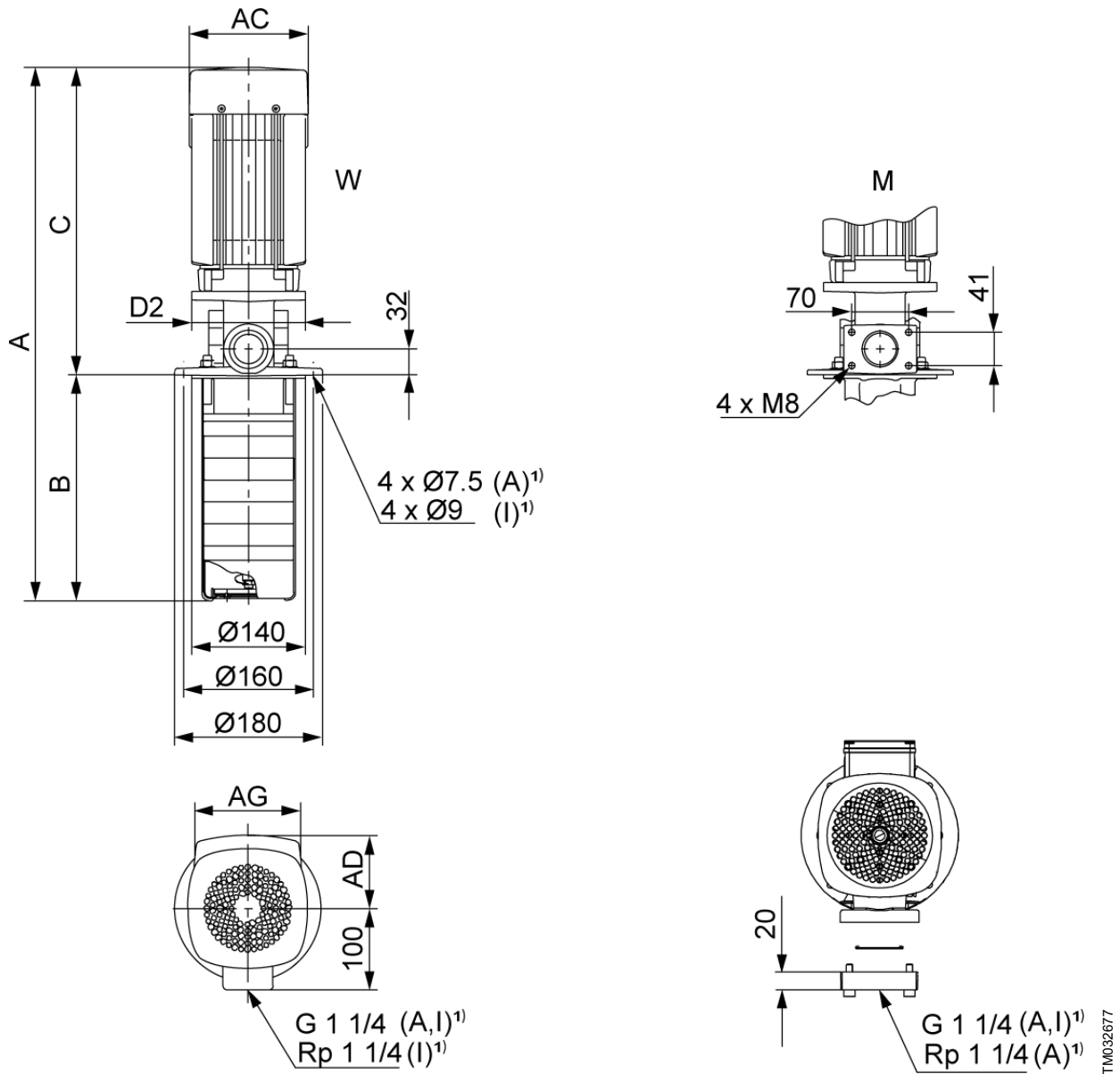

W: Internal thread connection. M: Square flange.

1) A: Basic version, cast iron. I: Stainless steel version.

Dimensions and weights

Pump type	P2 [kW]	MTR								Net weight [kg]	MTRE						Net weight [kg]
		Dimensions [mm]									Dimensions [mm]						
		A	B	C	AC	D2	AD	AG	A		B	C	AC	D2	AD	AG	
MTR 1-2/2	0.37	462	160	302	141	140	109	82	12.9	-	-	-	-	-	-	-	-
MTR 1-3/3	0.37	480	178	302	141	140	109	82	13	-	-	-	-	-	-	-	-
MTR 1-4/4	0.37	498	196	302	141	140	109	82	13	-	-	-	-	-	-	-	-
MTR, MTRE 1-5/5	0.37	516	214	302	141	140	109	82	13	579	214	365	122	140	158	268	17.4
MTR 1-6/6	0.37	534	232	302	141	140	109	82	13	-	-	-	-	-	-	-	-
MTR 1-7/7	0.37	552	250	302	141	140	109	82	13.1	-	-	-	-	-	-	-	-
MTR, MTRE 1-8/8	0.55	570	268	302	141	140	109	82	12.5	633	268	365	122	140	158	268	17.5
MTR 1-9/9	0.55	588	286	302	141	140	109	82	12.6	-	-	-	-	-	-	-	-
MTR 1-10/10	0.55	606	304	302	141	140	109	82	12.6	-	-	-	-	-	-	-	-
MTR 1-11/11	0.55	624	322	302	141	140	109	82	12.6	-	-	-	-	-	-	-	-

Pump type	P2 [kW]	MTR								MTRE							
		Dimensions [mm]							Net weight [kg]	Dimensions [mm]							Net weight [kg]
		A	B	C	AC	D2	AD	AG		A	B	C	AC	D2	AD	AG	
MTR, MTRE 1-12/12	0.75	682	340	342	141	140	109	82	14.9	705	340	365	122	140	158	268	17.7
MTR 1-13/13	0.75	700	358	342	141	140	109	82	14.9	-	-	-	-	-	-	-	-
MTR, MTRE 1-15/15	0.75	736	394	342	141	140	109	82	15	759	394	365	122	140	158	268	17.7
MTR 1-17/17	1.1	792	430	362	141	140	109	82	17	-	-	-	-	-	-	-	-
MTR 1-19/19	1.1	828	466	362	141	140	109	82	17.1	-	-	-	-	-	-	-	-
MTR 1-21/21	1.1	864	502	362	141	140	109	82	17.1	-	-	-	-	-	-	-	-
MTR 1-22/22	1.1	882	520	362	141	140	109	82	17.1	-	-	-	-	-	-	-	-
MTR, MTRE 1-23/23	1.1	900	538	362	141	140	109	82	17.2	903	538	365	122	140	158	268	18.7
MTR 1-25/25	1.5	966	574	392	178	140	110	162	23.6	-	-	-	-	-	-	-	-
MTR 1-26/26	1.5	984	592	392	178	140	110	162	23.6	-	-	-	-	-	-	-	-
MTR 1-27/27	1.5	1002	610	392	178	140	110	162	23.6	-	-	-	-	-	-	-	-
MTR, MTRE 1-30/30	1.5	1056	664	392	178	140	110	162	23.7	1049	664	385	122	140	158	268	21.7
MTR 1-33/33	2.2	1150	718	432	178	140	110	162	27.6	-	-	-	-	-	-	-	-
MTR, MTRE 1-36/36	2.2	1204	772	432	178	140	110	162	27.6	1157	772	385	122	140	158	268	23.3

The maximum immersion depth is 1006 mm.

MTR, MTRE 3, 50 Hz

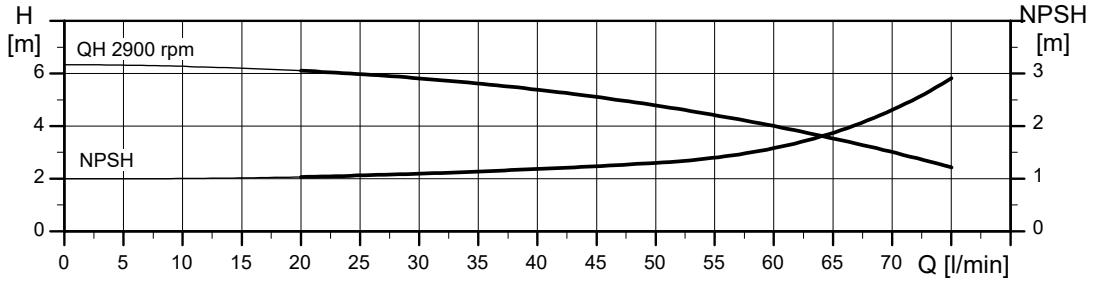
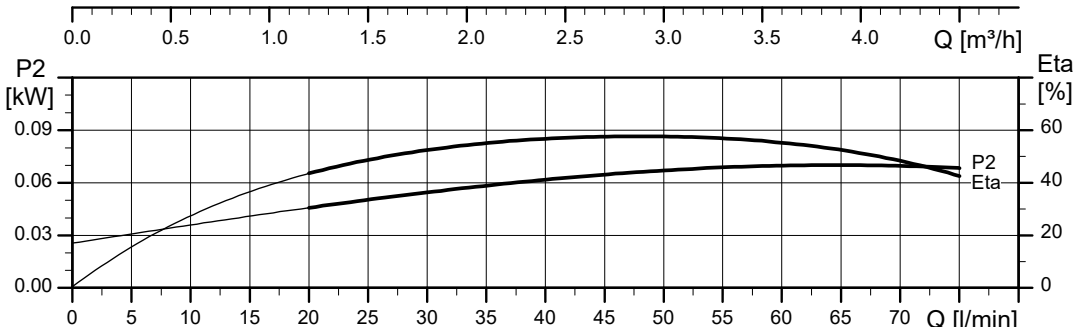
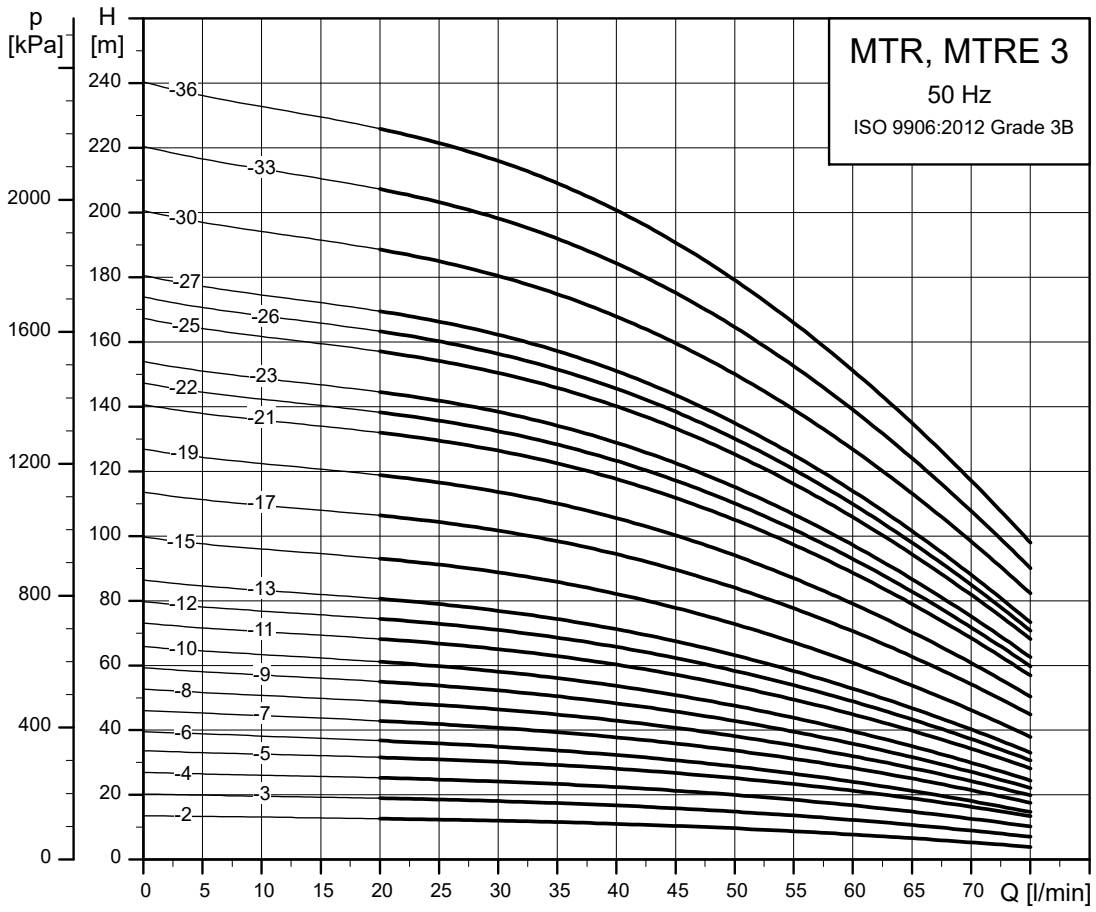

TM027841

Dimensional sketches

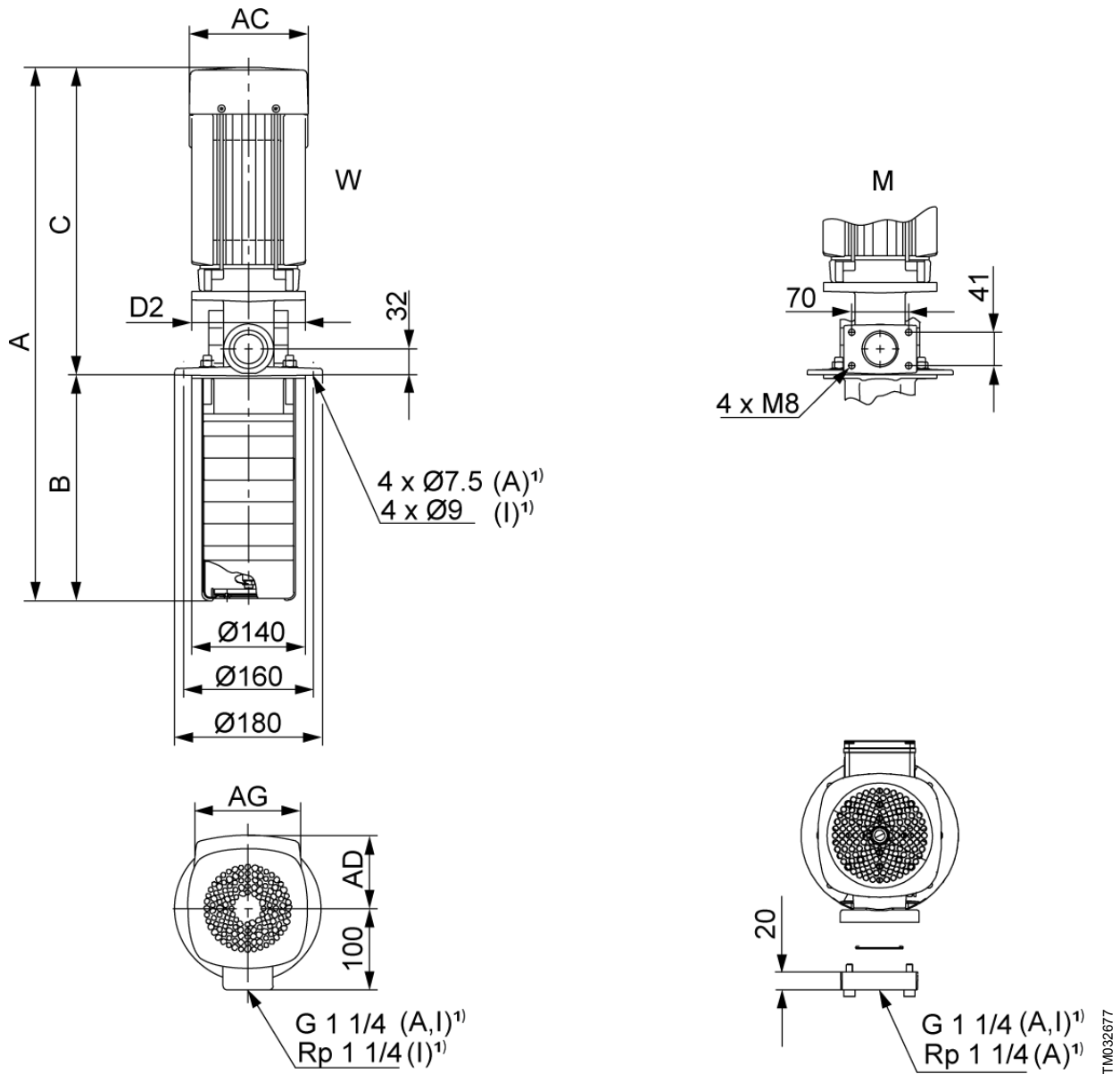

W: Internal thread connection. M: Square flange.

1) A: Basic version, cast iron. I: Stainless steel version.

Dimensions and weights

Pump type	P2 [kW]	MTR								Net weight [kg]	MTRE						
		Dimensions [mm]									Dimensions [mm]						
		A	B	C	AC	D2	AD	AG	A		B	C	AC	D2	AD	AG	
MTR 3-2/2	0.37	462	160	302	141	140	109	82	12.9	-	-	-	-	-	-	-	-
MTR 3-3/3	0.37	480	178	302	141	140	109	82	13	-	-	-	-	-	-	-	-
MTR 3-4/4	0.37	498	196	302	141	140	109	82	13	-	-	-	-	-	-	-	-
MTR, MTRE 3-5/5	0.37	516	214	302	141	140	109	82	13	579	214	365	122	140	158	268	17.4
MTR 3-6/6	0.55	534	232	302	141	140	109	82	12.5	-	-	-	-	-	-	-	-
MTR 3-7/7	0.55	552	250	302	141	140	109	82	12.5	-	-	-	-	-	-	-	-
MTR, MTRE 3-8/8	0.75	610	268	342	141	140	109	82	14.8	633	268	365	122	140	158	268	17.6
MTR 3-9/9	0.75	628	286	342	141	140	109	82	14.8	-	-	-	-	-	-	-	-
MTR 3-10/10	0.75	646	304	342	141	140	109	82	14.9	-	-	-	-	-	-	-	-
MTR, MTRE 3-11/11	0.75	664	322	342	141	140	109	82	14.9	687	322	365	122	140	158	268	17.6

TM032677

Pump type	P2 [kW]	MTR								MTRE								
		Dimensions [mm]							Net weight [kg]	Dimensions [mm]							Net weight [kg]	
		A	B	C	AC	D2	AD	AG		A	B	C	AC	D2	AD	AG		
MTR 3-12/12	1.1	702	340	362	141	140	109	82	16.9	-	-	-	-	-	-	-	-	-
MTR 3-13/13	1.1	720	358	362	141	140	109	82	16.9	-	-	-	-	-	-	-	-	-
MTR, MTRE 3-15/15	1.1	756	394	362	141	140	109	82	17	759	394	365	122	140	158	268	18.5	
MTR 3-17/17	1.5	822	430	392	178	140	110	162	23.4	-	-	-	-	-	-	-	-	
MTR, MTRE 3-19/19	1.5	858	466	392	178	140	110	162	23.4	851	466	385	122	140	158	268	21.5	
MTR 3-21/21	2.2	934	502	432	178	140	110	162	27.3	-	-	-	-	-	-	-	-	
MTR 3-22/22	2.2	952	520	432	178	140	110	162	27.3	-	-	-	-	-	-	-	-	
MTR 3-23/23	2.2	970	538	432	178	140	110	162	27.3	-	-	-	-	-	-	-	-	
MTR, MTRE 3-25/25	2.2	1006	574	432	178	140	110	162	27.4	959	574	385	122	140	158	268	23	
MTR 3-26/26	2.2	1024	592	432	178	140	110	162	27.4	-	-	-	-	-	-	-	-	
MTR 3-27/27	2.2	1042	610	432	178	140	110	162	27.4	-	-	-	-	-	-	-	-	
MTR, MTRE 3-30/30	3	1110	664	446	198	160	120	162	32.5	1109	664	445	191	160	201	291	32.4	
MTR 3-33/33	3	1164	718	446	198	160	120	162	32.6	-	-	-	-	-	-	-	-	
MTR, MTRE 3-36/36	3	1218	772	446	198	160	120	162	32.6	1217	772	445	191	160	201	291	32.5	

The maximum immersion depth is 1006 mm.

MTR, MTRE 5, 50 Hz

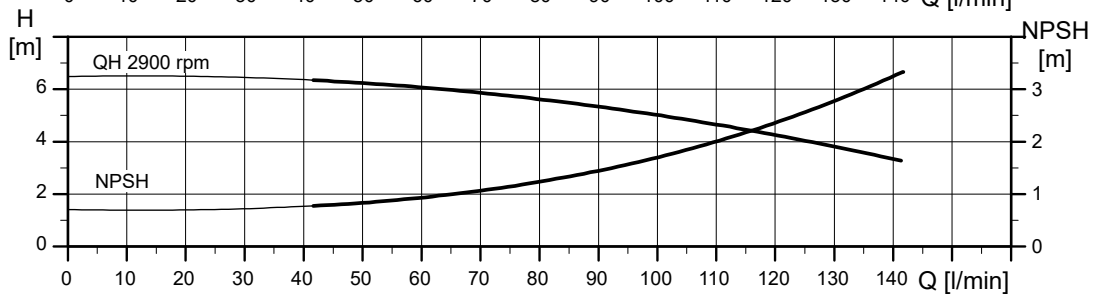
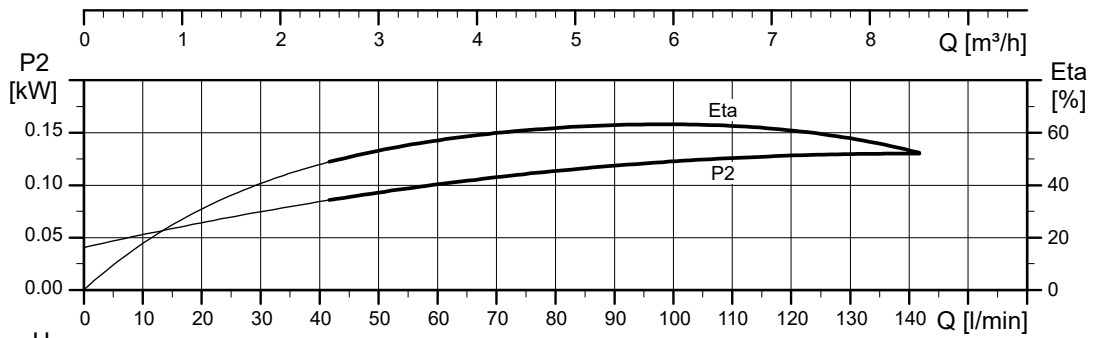
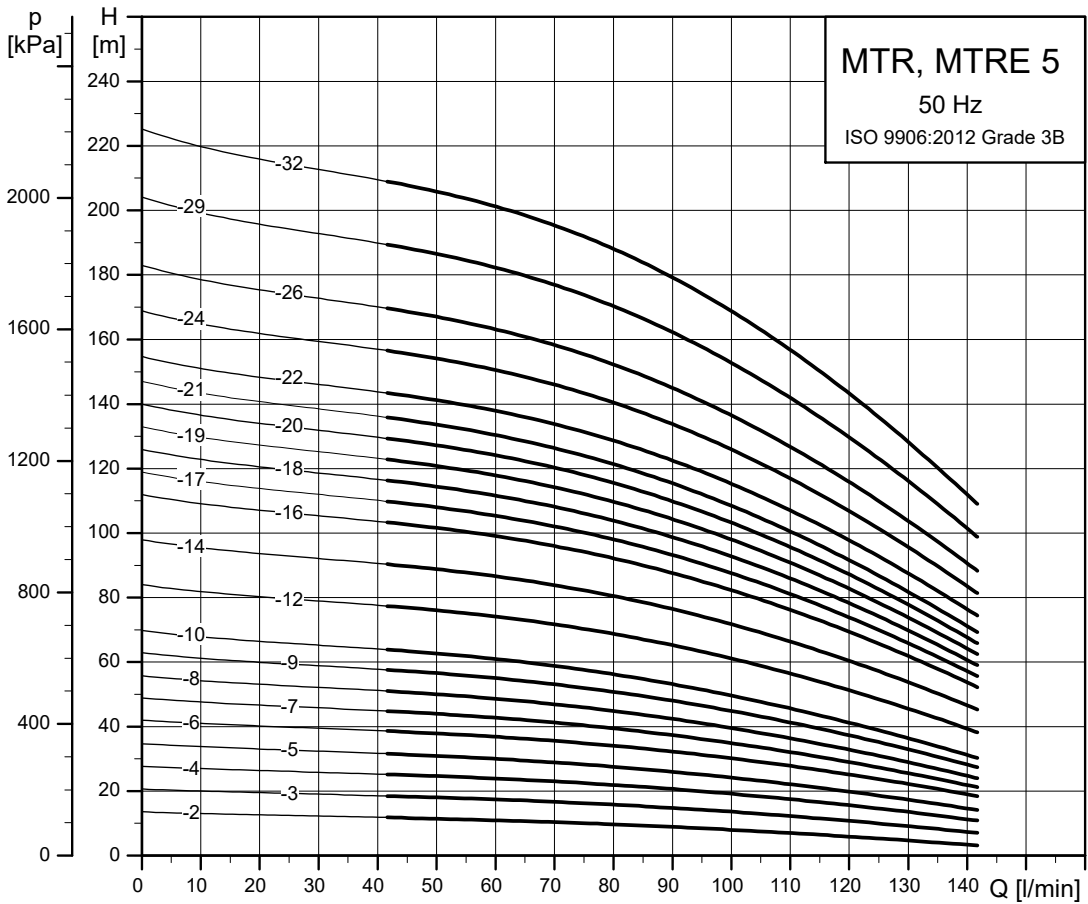

TW027842

Dimensional sketches

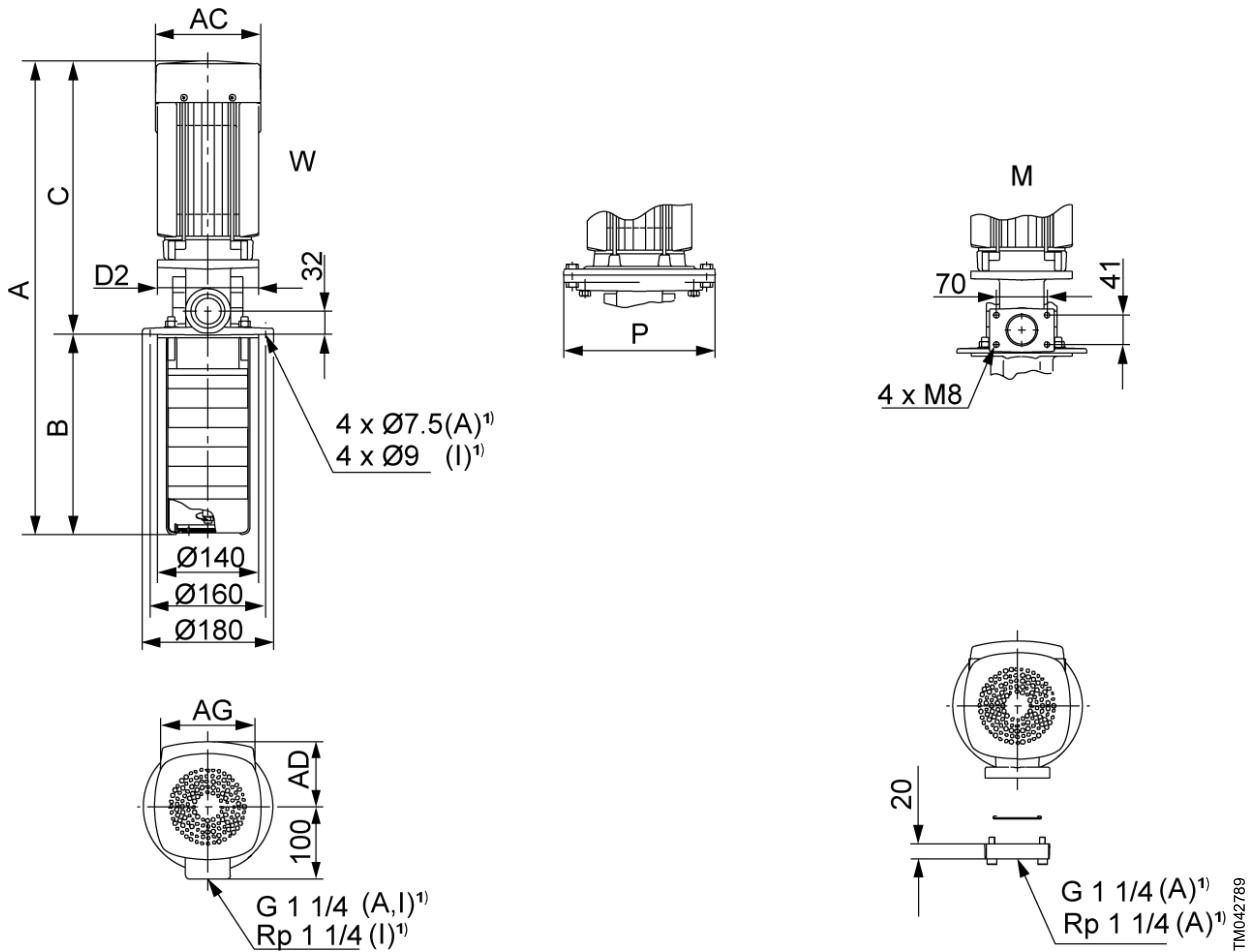

W: Internal thread connection. M: Square flange.

1) A: Basic version, cast iron. I: Stainless steel version.

Dimensions and weights

Pump type	P2 [kW]	MTR								MTRE									
		Dimensions [mm]								Net weight [kg]	Dimensions [mm]								Net weight [kg]
		A	B	C	AC	D2	P	AD	AG		A	B	C	AC	D2	P	AD	AG	
MTR, MTRE 5-2/2	0.37	471	169	302	141	140	-	109	82	13.2	534	169	365	122	140	-	158	268	17.6
MTR 5-3/3	0.55	498	196	302	141	140	-	109	82	12.7	-	-	-	-	-	-	-	-	-
MTR, MTRE 5-4/4	0.55	525	223	302	141	140	-	109	82	12.7	588	223	365	122	140	-	158	268	17.7
MTR, MTRE 5-5/5	0.75	592	250	342	141	140	-	109	82	15.1	615	250	365	122	140	-	158	268	17.8
MTR 5-6/6	1.1	639	277	362	141	140	-	109	82	17.1	-	-	-	-	-	-	-	-	-
MTR 5-7/7	1.1	666	304	362	141	140	-	109	82	17.1	-	-	-	-	-	-	-	-	-
MTR, MTRE 5-8/8	1.1	693	331	362	141	140	-	109	82	17.2	696	331	365	122	140	-	158	268	18.7
MTR 5-9/9	1.5	750	358	392	178	140	-	110	162	25.3	-	-	-	-	-	-	-	-	-
MTR, MTRE 5-10/10	1.5	777	385	392	178	140	-	110	162	25.3	770	385	385	122	140	-	158	268	21.7
MTR 5-12/12	2.2	871	439	432	178	140	-	110	162	28.5	-	-	-	-	-	-	-	-	-
MTR 5-14/14	2.2	925	493	432	178	140	-	110	162	28.6	-	-	-	-	-	-	-	-	-
MTR, MTRE 5-16/16	2.2	979	547	432	178	140	-	110	162	28.6	932	547	385	122	140	-	158	268	23.2
MTR 5-17/17	3	1020	574	446	198	160	-	120	162	32.7	-	-	-	-	-	-	-	-	-
MTR 5-18/18	3	1047	601	446	198	160	-	120	162	32.7	-	-	-	-	-	-	-	-	-
MTR 5-19/19	3	1074	628	446	198	160	-	120	162	32.7	-	-	-	-	-	-	-	-	-
MTR, MTRE 5-20/20	3	1101	655	446	198	160	-	120	162	32.8	1100	655	445	191	160	-	201	291	32.6
MTR 5-21/21	3	1128	682	446	198	160	-	120	162	32.8	-	-	-	-	-	-	-	-	-
MTR, MTRE 5-22/22	4	1192	709	483	220	160	-	134	202	44.5	1154	709	445	191	160	-	201	291	35.8

Pump type	P2 [kW]	MTR									MTRE										
		Dimensions [mm]									Net weight [kg]	Dimensions [mm]									Net weight [kg]
		A	B	C	AC	D2	P	AD	AG	A		B	C	AC	D2	P	AD	AG			
MTR 5-24/24	4	1246	763	483	220	160	-	134	202	44.6	-	-	-	-	-	-	-	-	-		
MTR 5-26/26	4	1300	817	483	220	160	-	134	202	44.7	-	-	-	-	-	-	-	-	-		
MTR, MTRE 5-29/29	4	1381	898	483	220	160	-	134	202	44.8	1343	898	445	191	160	-	201	291	36.0		
MTR, MTRE 5-32/32	5.5	1506	979	527	220	-	300	134	202	62.1	1480	979	501	191	300	300	201	291	57.4		

The maximum immersion depth is 1006 mm.

MTR, MTRE 8, 50 Hz

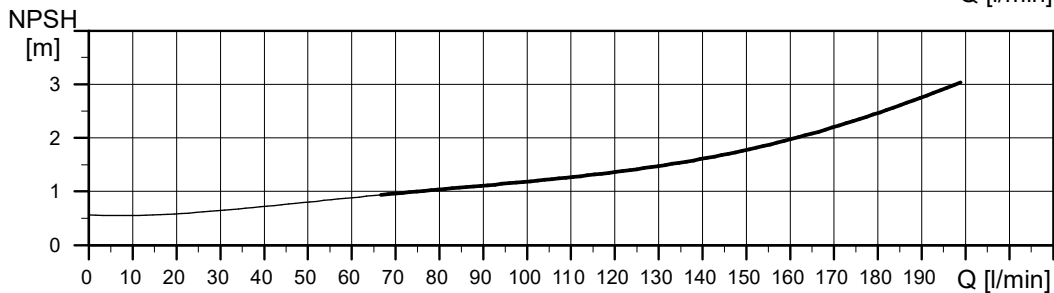
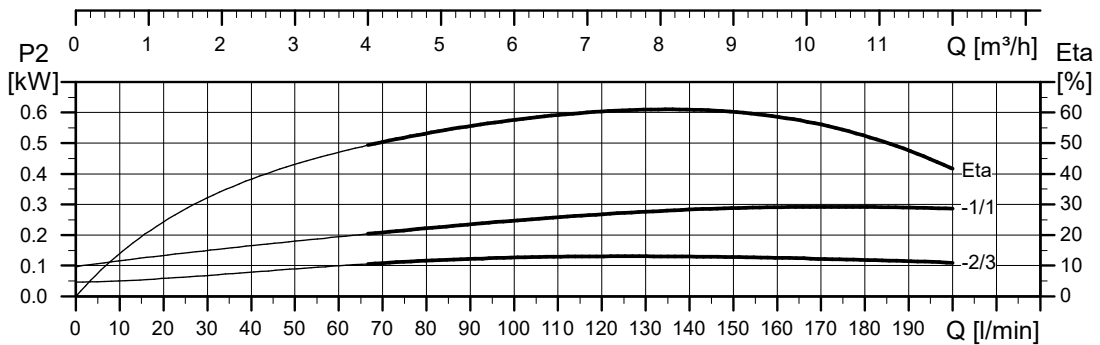
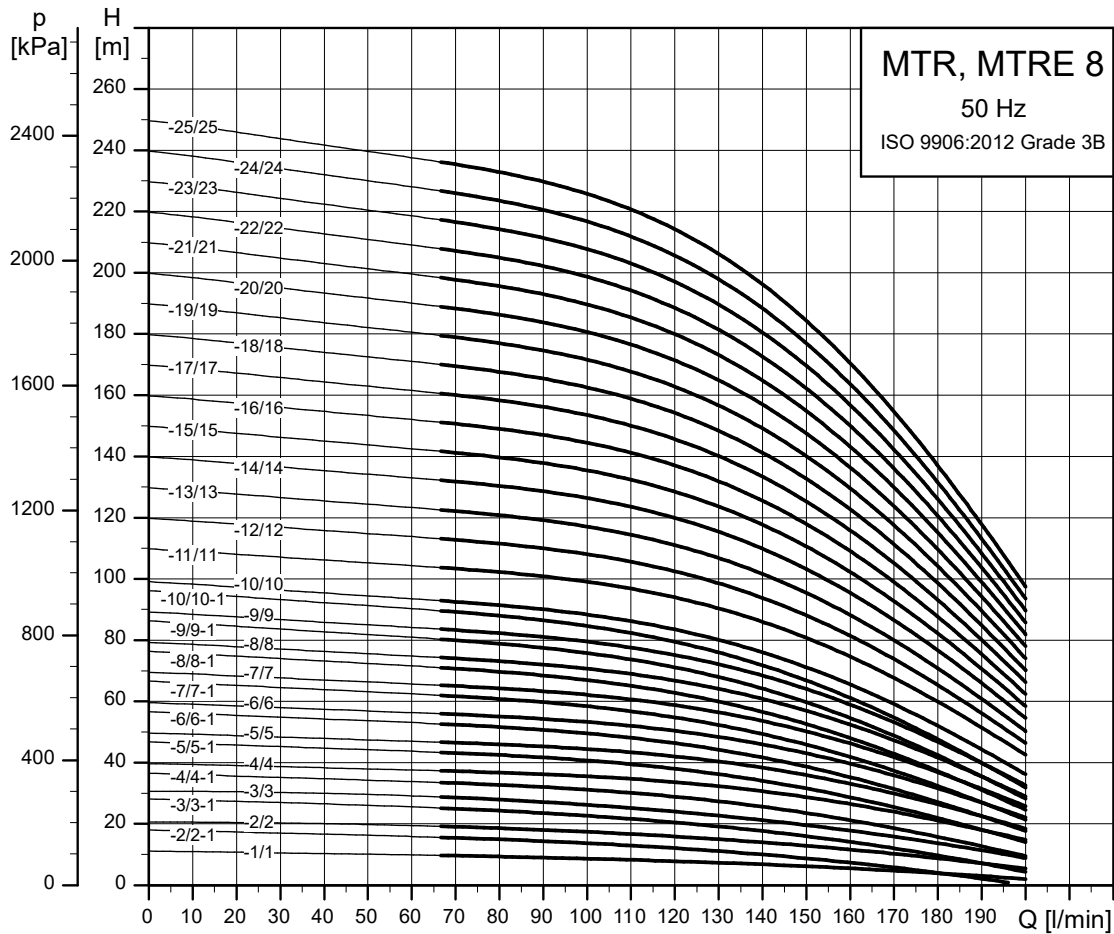

TM062363

Dimensional sketches

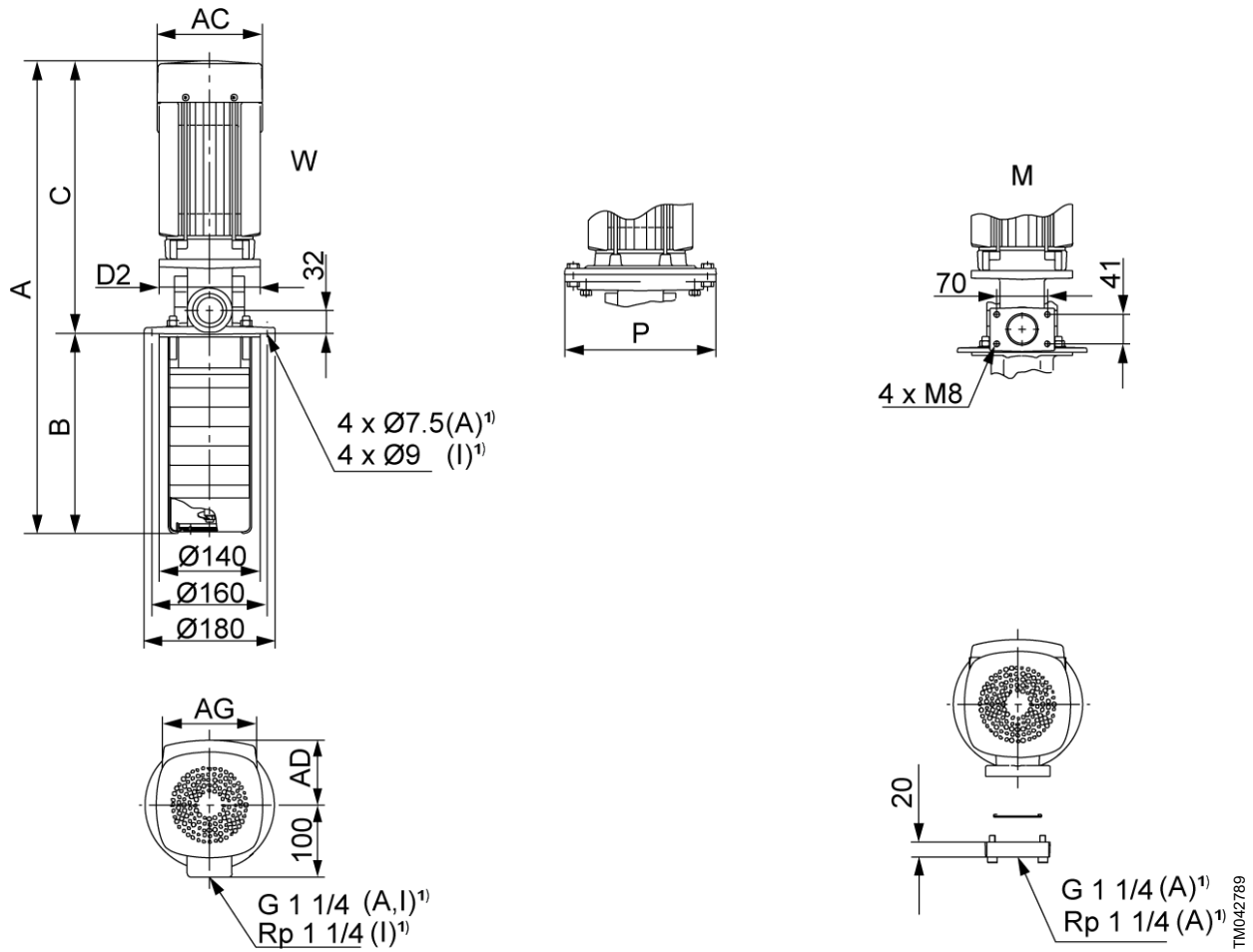

W: Internal thread connection. M: Square flange.

1) A: Basic version, cast iron. I: Stainless steel version.

Dimensions and weights

Pump type	P2 [kW]	MTR								Net weight [kg]	MTRE								
		Dimensions [mm]									Dimensions [mm]								
		A	B	C	AC	D2	P	AD	AG		A	B	C	AC	D2	P	AD	AG	
MTR, MTRE 8-1/1	0.37	498	196	302	141	140	-	109	82	17.6	561	196	365	122	140	-	158	268	22.0
MTR, MTRE 8-2/2-1	0.55	525	223	302	141	140	-	109	82	17.1	588	223	365	122	140	-	158	268	22.0
MTR 8-2/2	0.75	565	223	342	141	140	-	109	82	19.4	-	-	-	-	-	-	-	-	-
MTR, MTRE 8-3/3-1	0.75	592	250	342	141	140	-	109	82	19.4	615	250	365	122	140	-	158	268	22.1
MTR 8-3/3	1.1	612	250	362	141	140	-	109	82	21.4	-	-	-	-	-	-	-	-	-
MTR, MTRE 8-4/4-1	1.1	639	277	362	141	140	-	109	82	21.4	642	277	365	122	140	-	158	268	22.9
MTR 8-4/4	1.5	669	277	392	178	140	-	110	162	27.8	-	-	-	-	-	-	-	-	-
MTR 8-5/5-1	1.5	696	304	392	178	140	-	110	162	27.8	-	-	-	-	-	-	-	-	-
MTR, MTRE 8-5/5	2.2	736	304	432	178	140	-	110	162	31.6	689	304	385	122	140	-	158	268	27.3
MTR 8-6/6-1	2.2	763	331	432	178	140	-	110	162	31.7	-	-	-	-	-	-	-	-	-
MTR 8-6/6	2.2	763	331	432	178	140	-	110	162	31.7	-	-	-	-	-	-	-	-	-
MTR 8-7/7-1	2.2	790	358	432	178	140	-	110	162	31.7	-	-	-	-	-	-	-	-	-
MTR, MTRE 8-7/7	2.2	790	358	432	178	140	-	110	162	31.7	743	358	385	122	140	-	158	268	27.3
MTR 8-8/8-1	3	831	385	446	198	160	-	120	162	36.8	-	-	-	-	-	-	-	-	-
MTR 8-8/8	3	831	385	446	198	160	-	120	162	36.8	-	-	-	-	-	-	-	-	-
MTR 8-9/9-1	3	858	412	446	198	160	-	120	162	36.8	-	-	-	-	-	-	-	-	-
MTR 8-9/9	3	858	412	446	198	160	-	120	162	36.8	-	-	-	-	-	-	-	-	-
MTR 8-10/10-1	3	885	439	446	198	160	-	120	162	36.8	-	-	-	-	-	-	-	-	-

Pump type	P2 [kW]	MTR									MTRE										
		Dimensions [mm]									Net weight [kg]	Dimensions [mm]									Net weight [kg]
		A	B	C	AC	D2	P	AD	AG	A		B	C	AC	D2	P	AD	AG			
MTR, MTRE 8-10/10	3	885	439	446	198	160	-	120	162	36.8	884	439	445	191	160	-	201	291	36.7		
MTR 8-11/11	4	949	466	483	220	160	-	134	202	48.6	-	-	-	-	-	-	-	-	-		
MTR 8-12/12	4	976	493	483	220	160	-	134	202	48.6	-	-	-	-	-	-	-	-	-		
MTR, MTRE 8-13/13	4	1003	520	483	220	160	-	134	202	48.6	965	520	445	191	160	-	201	291	39.9		
MTR 8-14/14	5.5	1074	547	527	220	300	300	134	202	65.9	-	-	-	-	-	-	-	-	-		
MTR 8-15/15	5.5	1101	574	527	220	300	300	134	202	65.9	-	-	-	-	-	-	-	-	-		
MTR 8-16/16	5.5	1128	601	527	220	300	300	134	202	65.9	-	-	-	-	-	-	-	-	-		
MTR 8-17/17	5.5	1155	628	527	220	300	300	134	202	66.0	-	-	-	-	-	-	-	-	-		
MTR, MTRE 8-18/18	5.5	1182	655	527	220	300	300	134	202	66.0	1156	655	501	191	300	300	201	291	61.3		
MTR 8-19/19	7.5	1197	682	515	260	300	300	159	203	75.8	-	-	-	-	-	-	-	-	-		
MTR 8-20/20	7.5	1224	709	515	260	300	300	159	203	75.9	-	-	-	-	-	-	-	-	-		
MTR 8-21/21	7.5	1251	736	515	260	300	300	159	203	75.9	-	-	-	-	-	-	-	-	-		
MTR 8-22/22	7.5	1278	763	515	260	300	300	159	203	75.9	-	-	-	-	-	-	-	-	-		
MTR 8-23/23	7.5	1305	790	515	260	300	300	159	203	76.0	-	-	-	-	-	-	-	-	-		
MTR 8-24/24	7.5	1332	817	515	260	300	300	159	203	76.0	-	-	-	-	-	-	-	-	-		
MTR, MTRE 8-25/25	7.5	1359	844	515	260	300	300	159	203	76.0	1369	844	525	255	300	300	237	346	70.9		

The maximum immersion depth is 1006 mm.

MTR, MTRE 10, 50 Hz

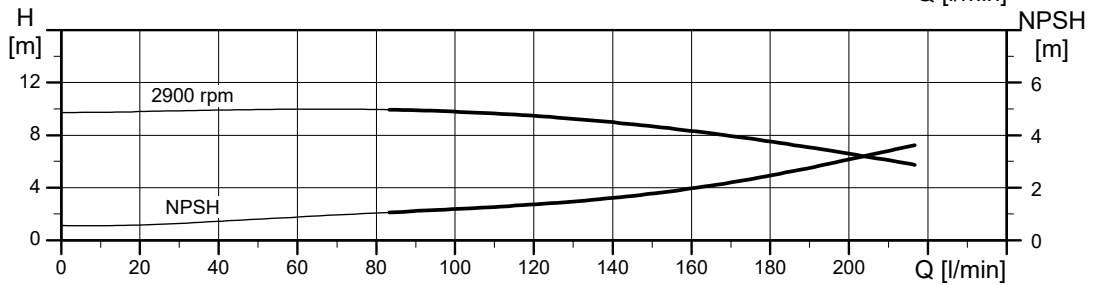
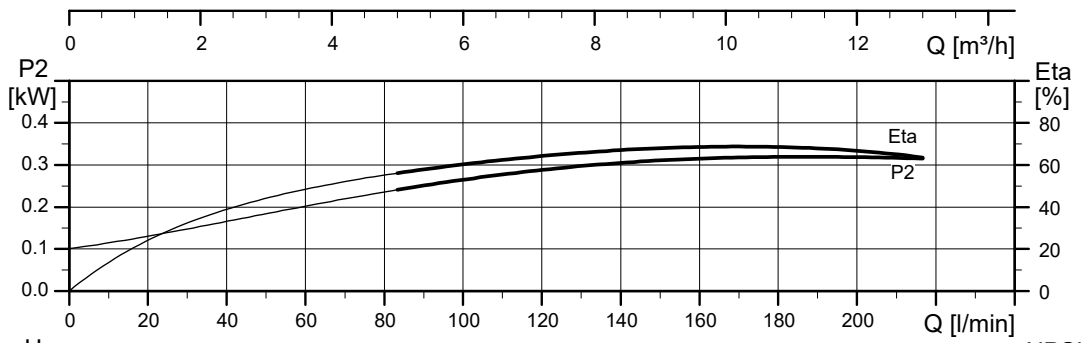
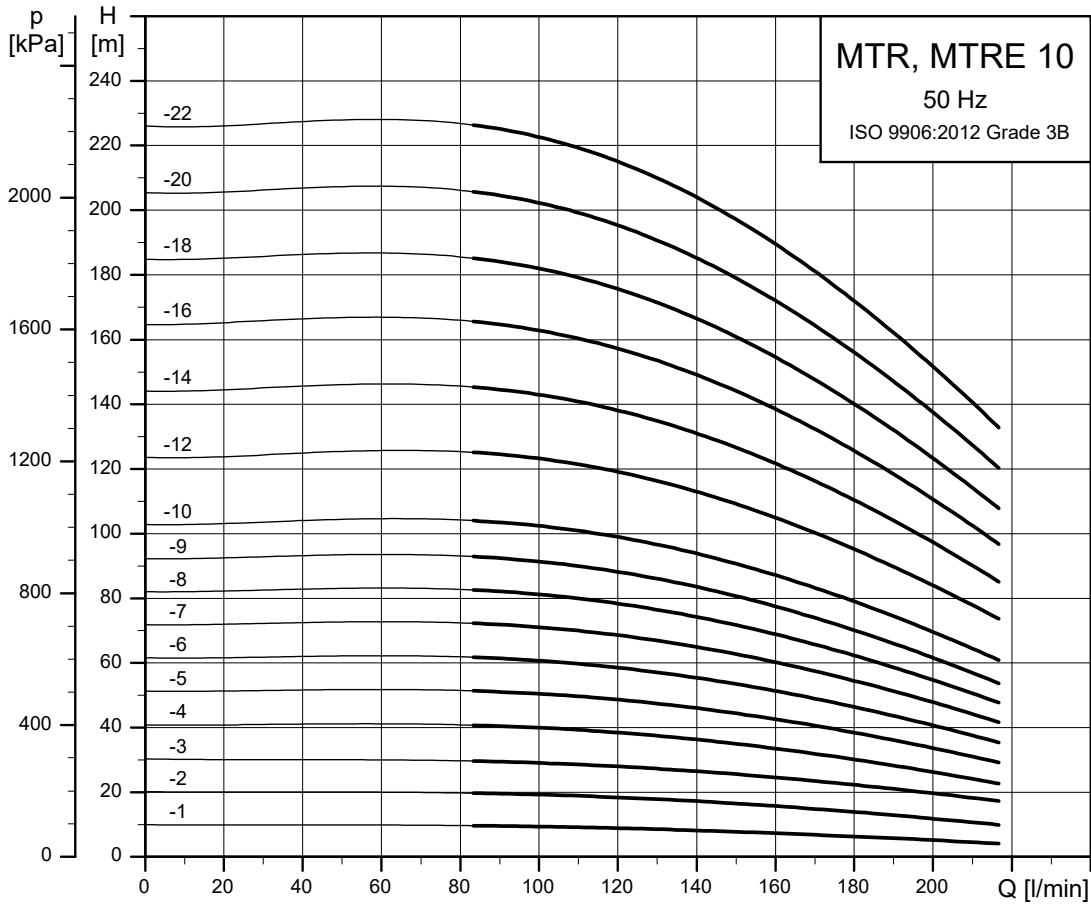

TM027843

Dimensional sketches

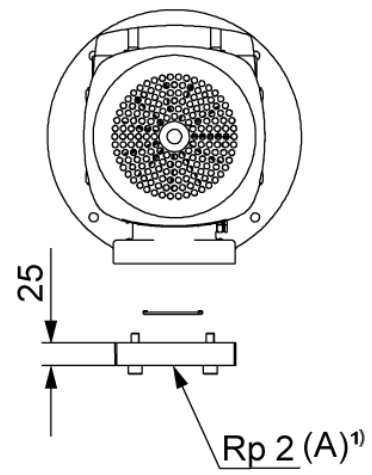
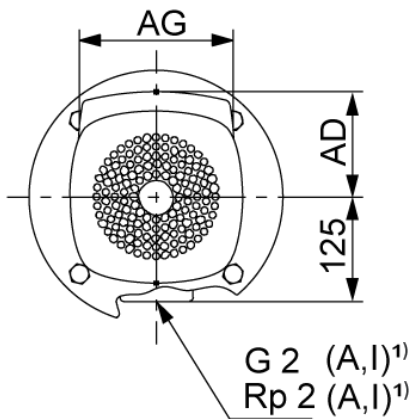
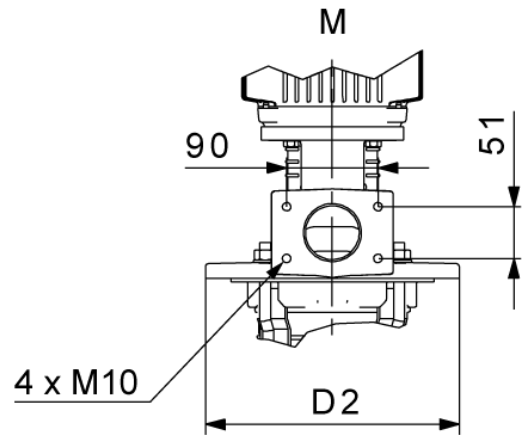
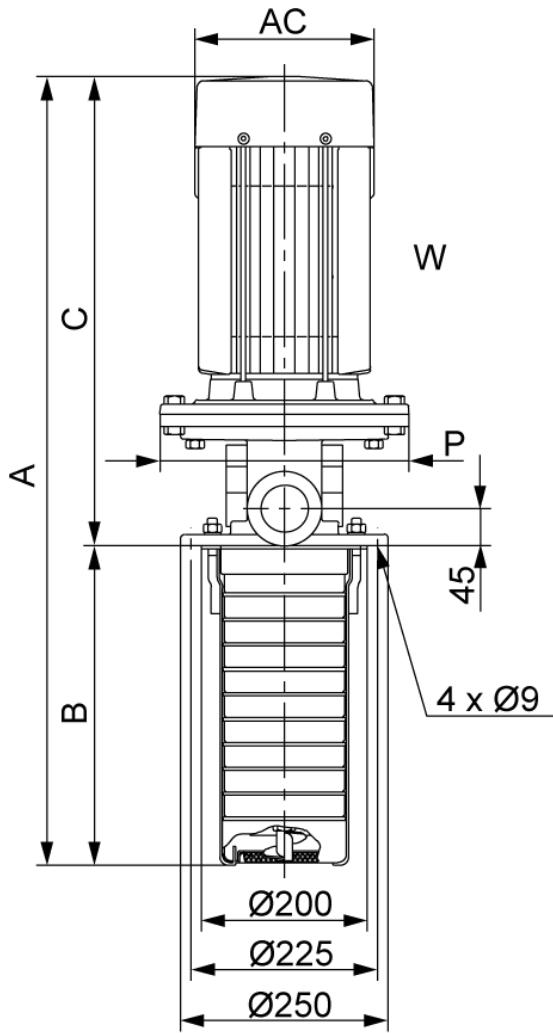

W: Internal thread connection. M: Square flange.

1) A: Basic version, cast iron. I: Stainless steel version.

TM042790

Dimensions and weights

Pump type	P2 [kW]	MTR									MTRE										
		Dimensions [mm]									Net weight [kg]	Dimensions [mm]									Net weight [kg]
		A	B	C	AC	D2	P	AD	AG	A		B	C	AC	D2	P	AD	AG			
MTR, MTRE 10-2/1	0.75	519	148	371	141	140	-	109	82	22.7	542	148	394	122	140	-	158	268	25.5		
MTR, MTRE 10-2/2	0.75	519	148	371	141	140	-	109	82	22.7	542	148	394	122	140	-	158	268	25.5		
MTR, MTRE 10-3/3	1.1	569	178	391	141	140	-	109	82	24.8	572	178	394	122	140	-	158	268	26.3		
MTR, MTRE 10-4/4	1.5	629	208	421	178	140	-	110	162	31.2	622	208	414	122	140	-	158	268	29.3		
MTR 10-5/5	2.2	699	238	461	178	140	-	110	162	35.1	-	-	-	-	-	-	-	-	-		
MTR, MTRE 10-6/6	2.2	729	268	461	178	140	-	110	162	35.2	682	268	414	122	140	-	158	268	30.8		
MTR 10-7/7	3	773	298	475	198	160	-	120	162	40.3	-	-	-	-	-	-	-	-	-		
MTR 10-8/8	3	803	328	475	198	160	-	120	162	40.4	-	-	-	-	-	-	-	-	-		
MTR, MTRE 10-9/9	3	833	358	475	198	160	-	120	162	40.4	832	358	474	191	160	-	201	291	40.3		
MTR 10-10/10	4	900	388	512	220	160	-	134	202	52.2	-	-	-	-	-	-	-	-	-		
MTR, MTRE 10-12/12	4	960	448	512	220	160	-	134	202	52.3	922	448	474	191	160	-	201	291	43.6		
MTR 10-14/14	5.5	1063	508	555	220	300	300	134	202	64.7	-	-	-	-	-	-	-	-	-		
MTR, MTRE 10-16/16	5.5	1123	568	555	220	300	300	134	202	64.8	1097	568	529	191	300	300	201	291	60.1		
MTR 10-18/18	7.5	1171	628	543	260	300	300	159	203	74.8	-	-	-	-	-	-	-	-	-		
MTR 10-20/20	7.5	1231	688	543	260	300	300	159	203	74.9	-	-	-	-	-	-	-	-	-		
MTR, MTRE 10-22/22	7.5	1291	748	543	260	300	300	159	203	75	1301	748	553	255	300	300	237	346	69.9		

The maximum immersion depth is 1018 mm.

MTR, MTRE 15, 50 Hz

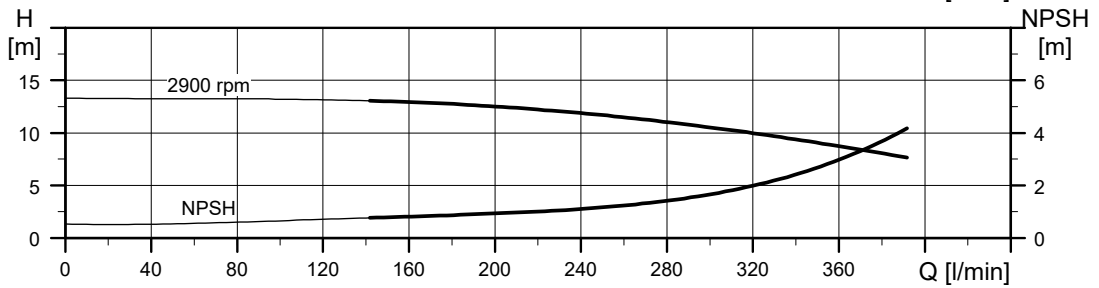
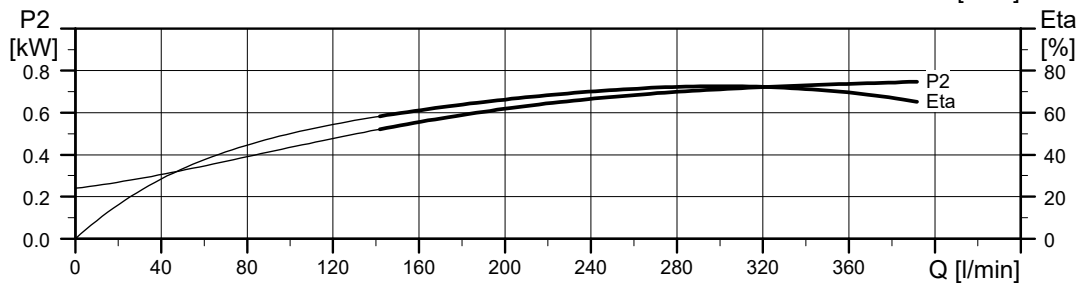
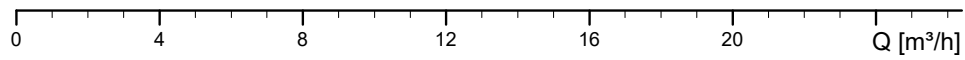
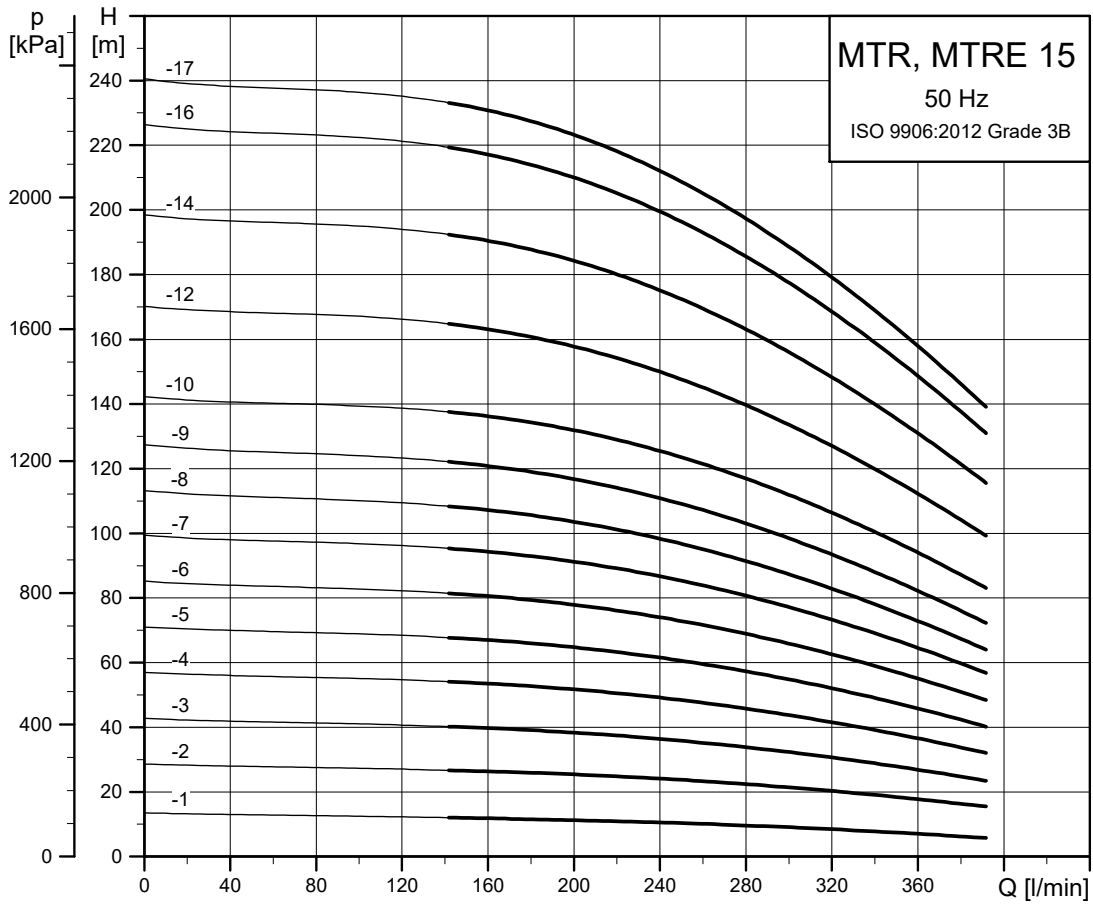

TM027844

Dimensional sketches

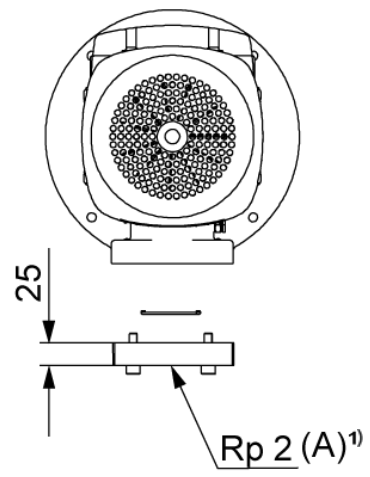
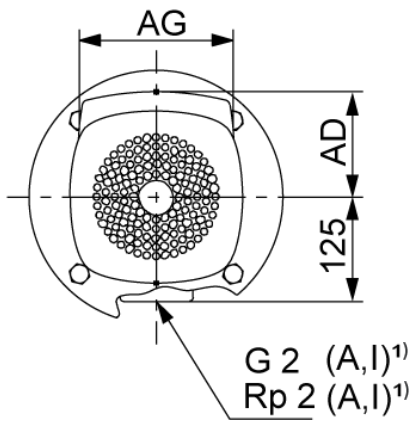
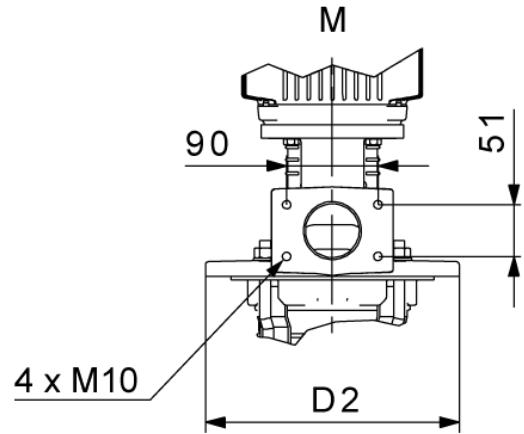
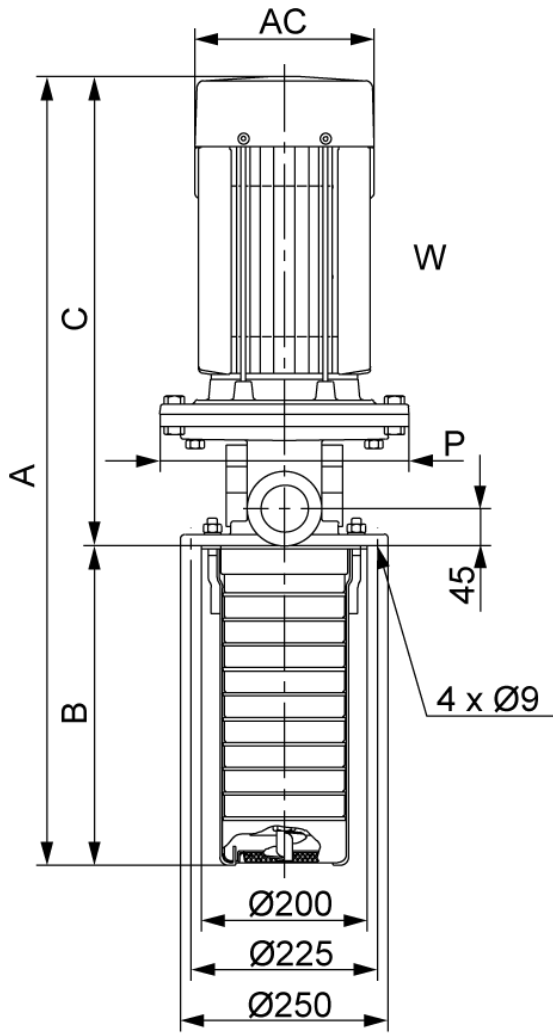

W: Internal thread connection. M: Square flange.

1) A: Basic version, cast iron. I: Stainless steel version.

TM042790

Dimensions and weights

Pump type	P2 [kW]	MTR									MTRE									
		Dimensions [mm]									Net weight [kg]	Dimensions [mm]								Net weight [kg]
		A	B	C	AC	D2	P	AD	AG	A		B	C	AC	D2	P	AD	AG		
MTR, MTRE 15-2/1	1.1	569	178	391	141	140	-	109	82	25.8	572	178	394	122	140	-	158	268	27.3	
MTR, MTRE 15-2/2	2.2	639	178	461	178	140	-	110	162	35.9	592	178	414	122	140	-	158	268	31.6	
MTR, MTRE 15-3/3	3	698	223	475	198	160	-	120	162	41.1	697	223	474	191	160	-	201	291	40.9	
MTR 15-4/4	4	780	268	512	220	160	-	134	202	52.9	-	-	-	-	-	-	-	-	-	
MTR, MTRE 15-5/5	4	825	313	512	220	160	-	134	202	53	787	313	474	191	160	-	201	291	44.2	
MTR 15-6/6	5.5	913	358	555	220	300	300	134	202	65.3	-	-	-	-	-	-	-	-	-	
MTR, MTRE 15-7/7	5.5	958	403	555	220	300	300	134	202	65.4	932	403	529	191	300	300	201	291	60.7	
MTR 15-8/8	7.5	991	448	543	260	300	300	159	203	75.3	-	-	-	-	-	-	-	-	-	
MTR, MTRE 15-9/9	7.5	1036	493	543	260	300	300	159	203	75.4	1046	493	553	255	300	300	237	346	70.3	
MTR 15-10/10	11	1214	538	676	318	350	350	204	243	113	-	-	-	-	-	-	-	-	-	
MTR 15-12/12	11	1304	628	676	318	350	350	204	243	113.2	-	-	-	-	-	-	-	-	-	
MTR, MTRE 15-14/14	11	1394	718	676	318	350	350	204	243	113.4	1318	718	600	255	350	350	237	346	90	
MTR 15-16/16	15	1484	808	676	318	350	350	204	243	125.4	-	-	-	-	-	-	-	-	-	
MTR 15-17/17	15	1529	853	676	318	350	350	204	243	125.5	-	-	-	-	-	-	-	-	-	

The maximum immersion depth is 1033 mm.

MTR, MTRE 20, 50 Hz

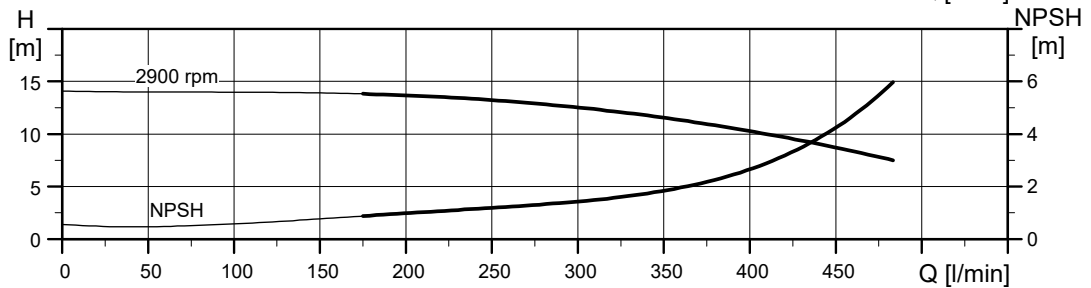
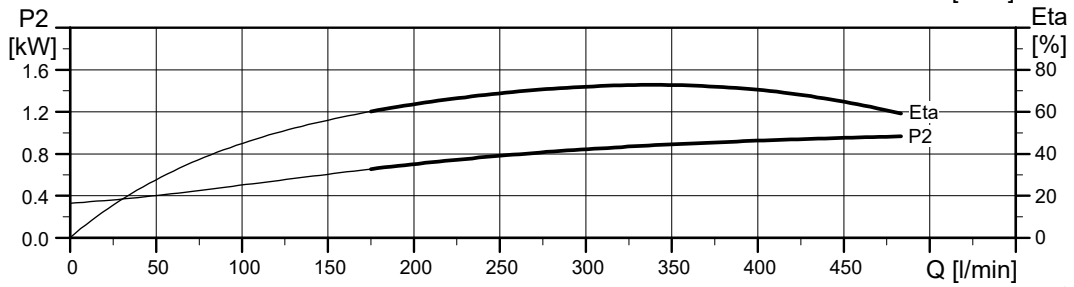
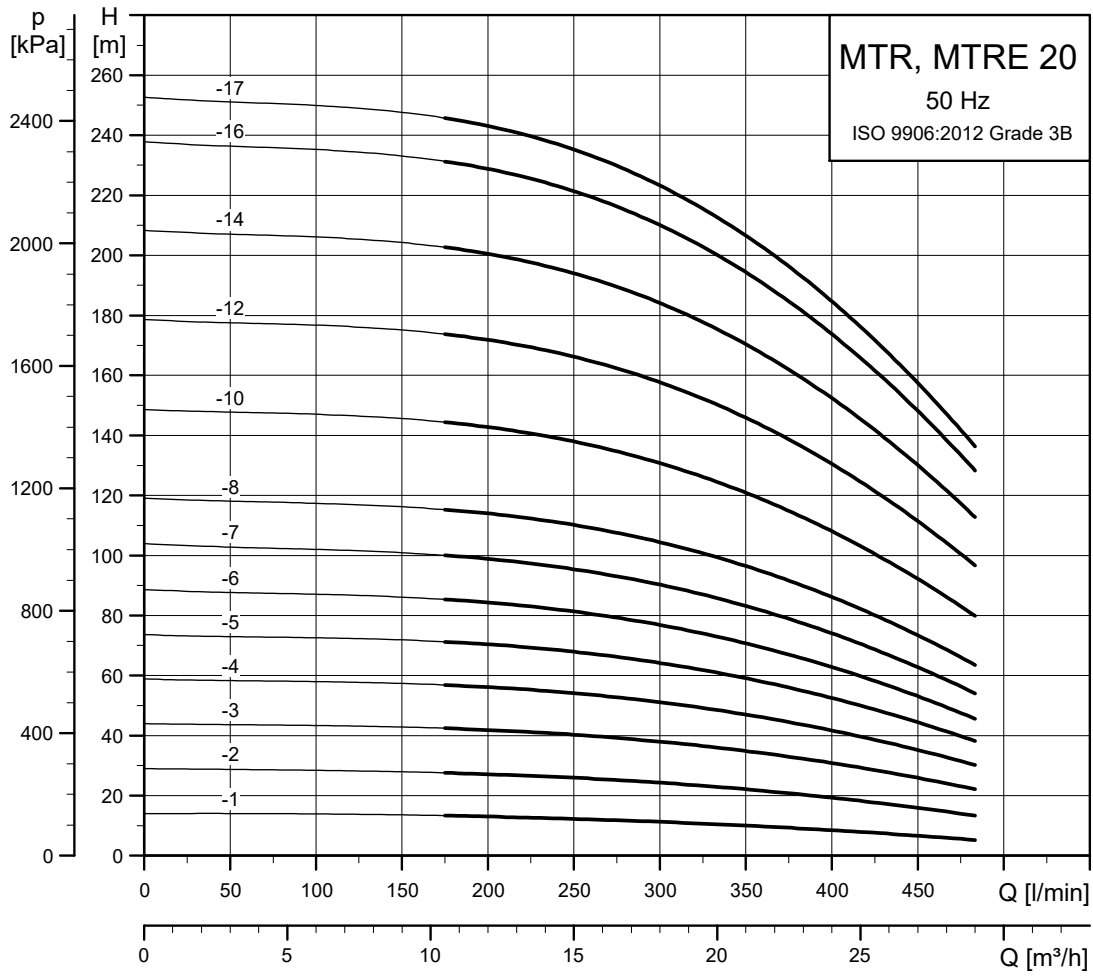

TM027845

Dimensional sketches

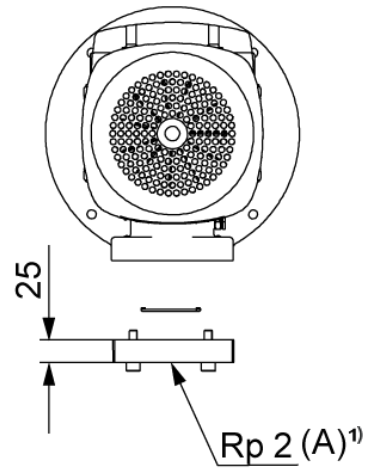
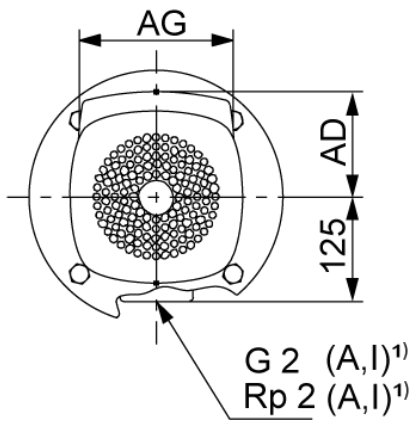
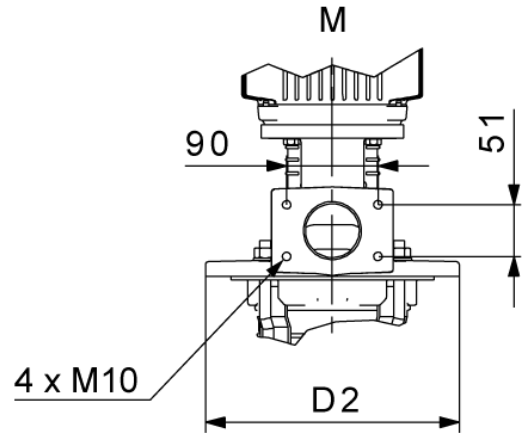
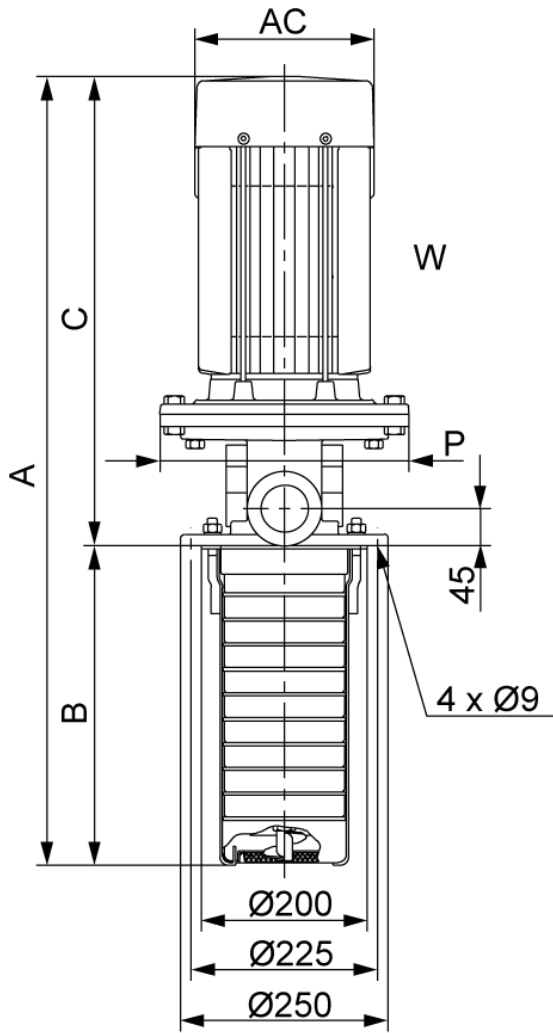

W: Internal thread connection. M: Square flange.

1) A: Basic version, cast iron. I: Stainless steel version.

TM042790

Dimensions and weights

Pump type	P2 [kW]	MTR									MTRE										
		Dimensions [mm]									Net weight [kg]	Dimensions [mm]									Net weight [kg]
		A	B	C	AC	D2	P	AD	AG	A		B	C	AC	D2	P	AD	AG			
MTR, MTRE 20-2/1	1.1	569	178	391	141	140	-	109	82	25.8	572	178	394	122	140	-	158	268	27.3		
MTR, MTRE 20-2/2	2.2	639	178	461	178	140	-	110	162	35.9	592	178	414	122	140	-	158	268	31.6		
MTR, MTRE 20-3/3	4	735	223	512	220	160	-	134	202	52.8	697	223	474	191	160	-	201	291	44		
MTR 20-4/4	5.5	823	268	555	220	300	300	134	202	65.1	-	-	-	-	-	-	-	-	-		
MTR, MTRE 20-5/5	5.5	868	313	555	220	300	300	134	202	65.2	842	313	529	191	300	300	201	291	60.5		
MTR 20-6/6	7.5	901	358	543	260	300	300	159	203	75.1	-	-	-	-	-	-	-	-	-		
MTR, MTRE 20-7/7	7.5	946	403	543	260	300	300	159	203	75.2	956	403	553	255	300	300	237	346	70.1		
MTR 20-8/8	11	1124	448	676	318	350	350	204	243	112.8	-	-	-	-	-	-	-	-	-		
MTR, MTRE 20-10/10	11	1214	538	676	318	350	350	204	243	113	1138	538	600	255	350	350	237	346	89.6		
MTR 20-12/12	15	1304	628	676	318	350	350	204	243	125	-	-	-	-	-	-	-	-	-		
MTR 20-14/14	15	1394	718	676	318	350	350	204	243	125.2	-	-	-	-	-	-	-	-	-		
MTR 20-16/16	18.5	1528	808	720	318	350	350	204	243	138.1	-	-	-	-	-	-	-	-	-		
MTR 20-17/17	18.5	1573	853	720	318	350	350	204	243	138.2	-	-	-	-	-	-	-	-	-		

The maximum immersion depth is 1033 mm.

MTR, MTRE 32, 50 Hz

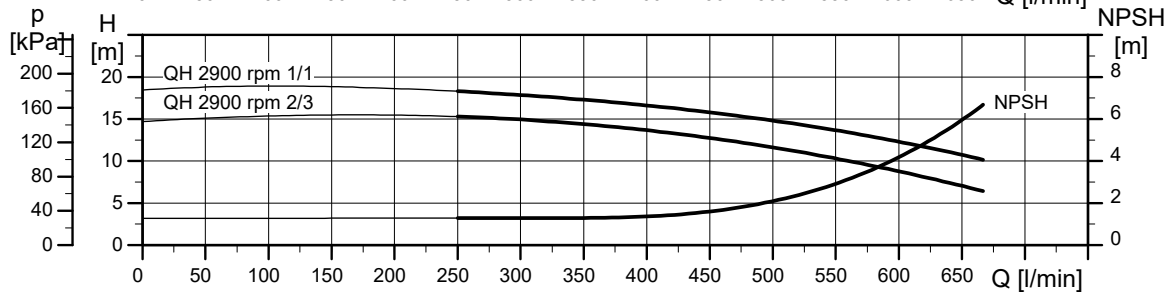
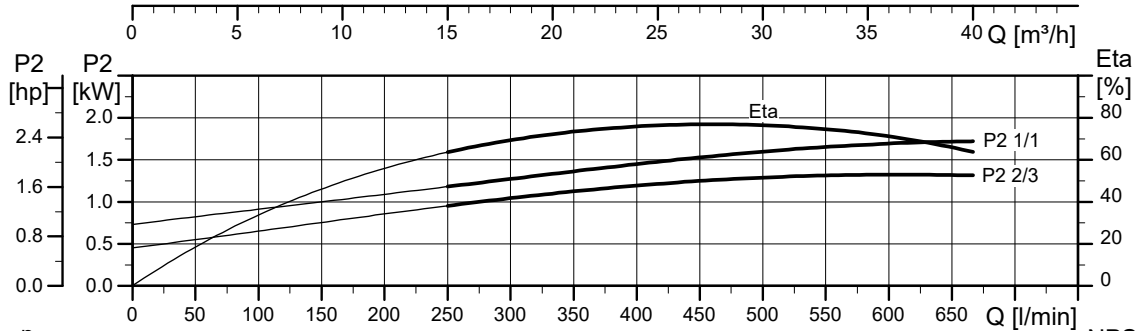
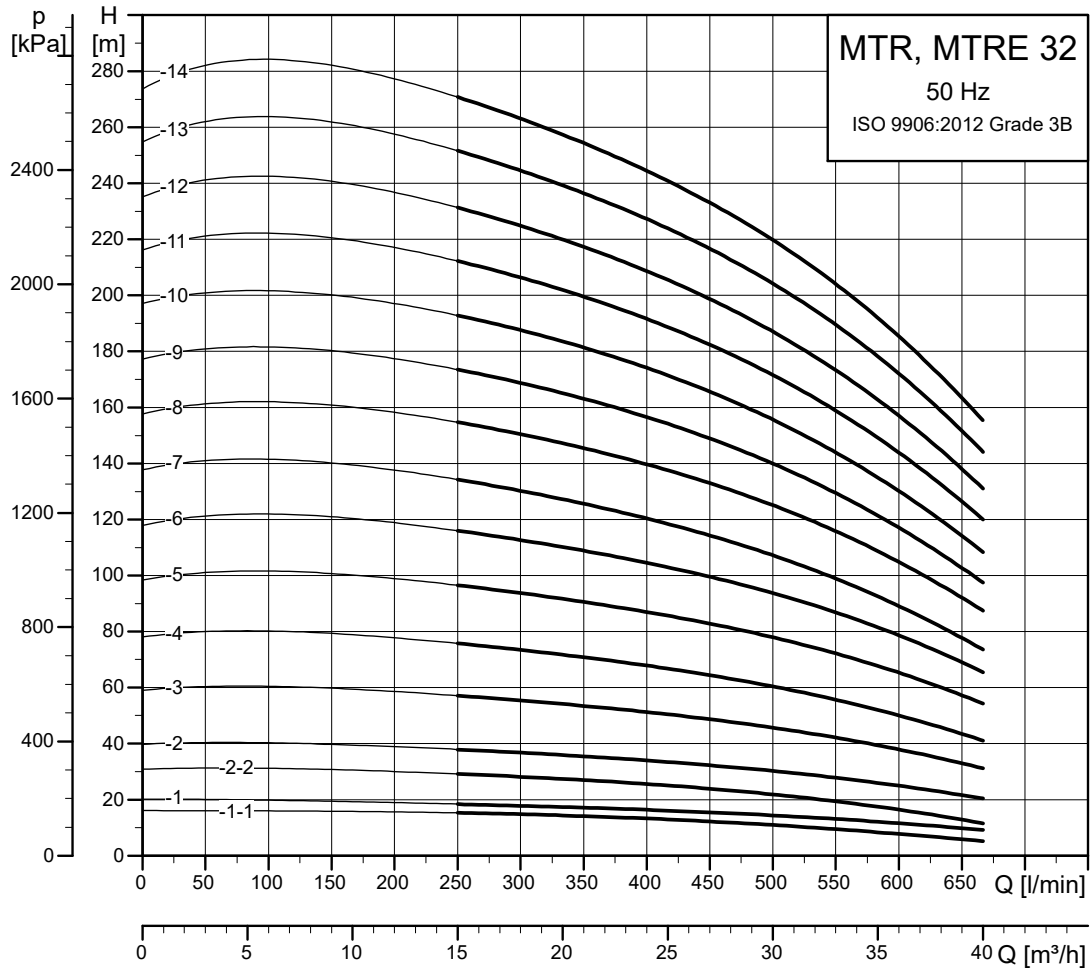

TM014302

Dimensional sketches

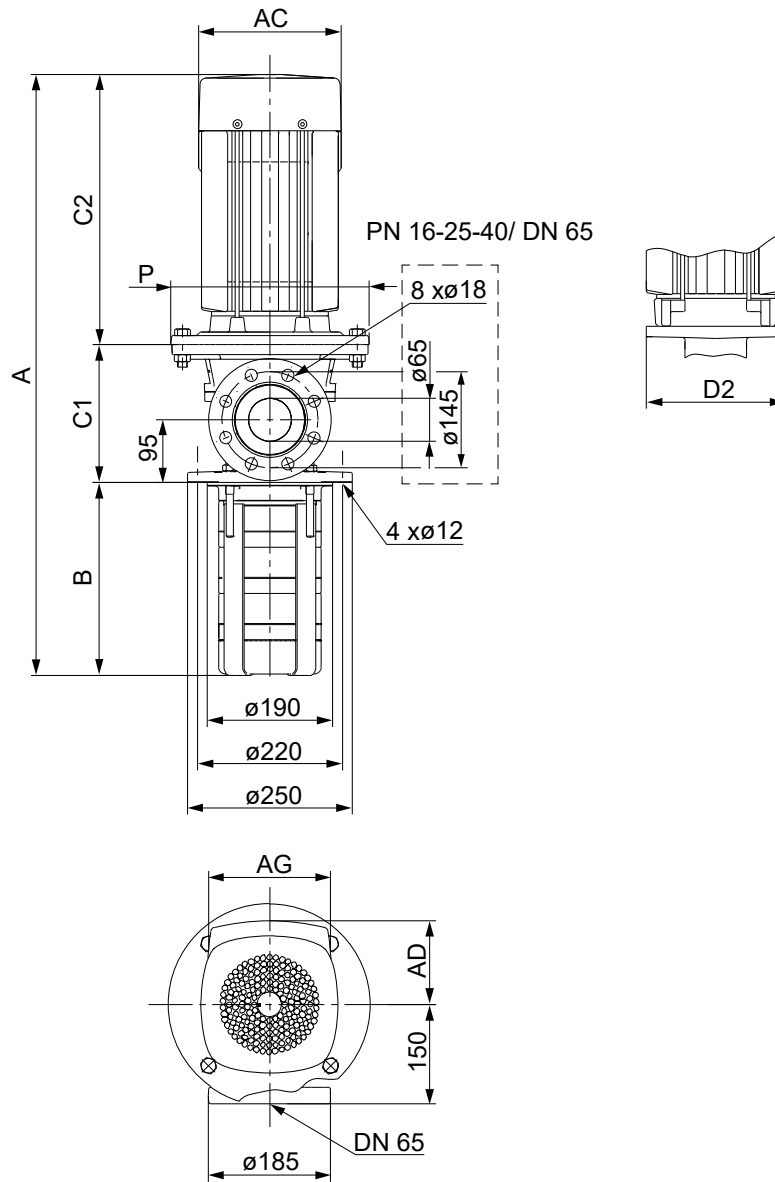

TM042791

Note that A and C1 are higher for drainage back to tank versions.

Dimensions and weights

Pump type	P2 [kW]	MTR										MTRE											
		Dimensions [mm]										Net weight [kg]	Dimensions [mm]										Net weight [kg]
		A ¹¹⁾	B	C1 ¹¹⁾	C2	AC	D2	P	AD	AG	A ¹¹⁾		B	C1 ¹¹⁾	C2	AC	D2	P	AD	AG			
MTR, MTRE 32-2/1-1	1.5	642	223	138	281	178	198	-	110	162	53.2	635	223	138	274	122	198	-	158	268	51.4		
MTR, MTRE 32-2/1	2.2	682	223	138	321	178	198	-	110	162	57.1	635	223	138	274	122	198	-	158	268	52.8		
MTR, MTRE 32-2/2-2	3	696	223	138	335	198	198	-	120	162	61.3	695	223	138	334	191	198	-	201	291	61.1		
MTR, MTRE 32-2/2	4	733	223	138	372	220	198	-	134	202	73	695	223	138	334	191	198	-	201	291	64.2		
MTR, MTRE 32-3/3	5.5	893	293	209	391	220	298	300	134	202	87.9	867	293	209	365	191	298	300	201	291	83.2		
MTR, MTRE 32-4/4	7.5	951	363	209	379	260	298	300	159	203	98	961	363	209	389	255	298	300	237	346	92.9		
MTR 32-5/5	11	1124	433	209	482	318	350	350	204	243	135.2	-	-	-	-	-	-	-	-	-	-		
MTR, MTRE 32-6/6	11	1194	503	209	482	318	350	350	204	243	135.5	1118	503	209	406	255	350	350	237	346	112.1		
MTR 32-7/7	15	1264	573	209	482	318	350	350	204	243	147.6	-	-	-	-	-	-	-	-	-	-		
MTR 32-8/8	15	1334	643	209	482	318	350	350	204	243	147.8	-	-	-	-	-	-	-	-	-	-		
MTR 32-9/9	18.5	1448	713	209	526	318	350	350	204	243	160.8	-	-	-	-	-	-	-	-	-	-		

Pump type	P2 [kW]	MTR										MTRE																
		Dimensions [mm]										Net weight [kg]	Dimensions [mm]										Net weight [kg]					
		A ¹⁾	B	C1 ¹⁾	C2	AC	D2	P	AD	AG	A ¹⁾		B	C1 ¹⁾	C2	AC	D2	P	AD	AG								
MTR 32-10/10	18.5	1518	783	209	526	318	350	350	204	243	161	-	-	-	-	-	-	-	-	-	-	-	-	-	-	-	-	-
MTR 32-11/11	22	1614	853	209	552	318	350	350	204	243	176.5	-	-	-	-	-	-	-	-	-	-	-	-	-	-	-	-	-
MTR 32-12/12	22	1684	923	209	552	318	350	350	204	243	176.8	-	-	-	-	-	-	-	-	-	-	-	-	-	-	-	-	-
MTR 32-13/13	30	1813	993	209	611	396	400	400	315	265	276.8	-	-	-	-	-	-	-	-	-	-	-	-	-	-	-	-	-
MTR 32-14/14	30	1883	1063	209	611	396	400	400	315	265	277.1	-	-	-	-	-	-	-	-	-	-	-	-	-	-	-	-	-

¹⁾+20 mm for MTR, MTRE pumps with drainage back to the tank.

The maximum immersion depth is 1343 mm.

MTR, MTRE 45, 50 Hz

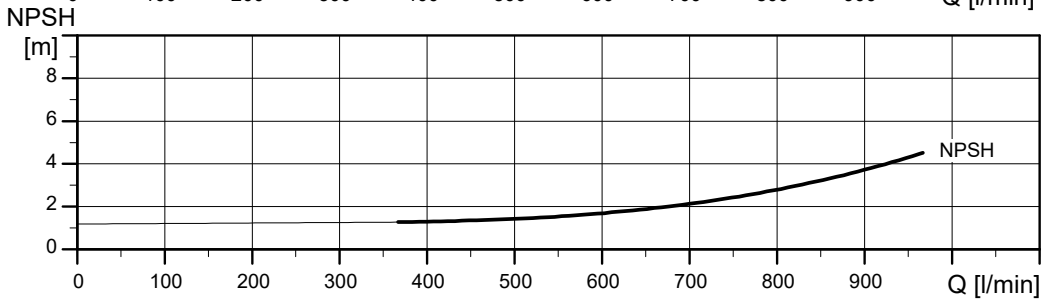
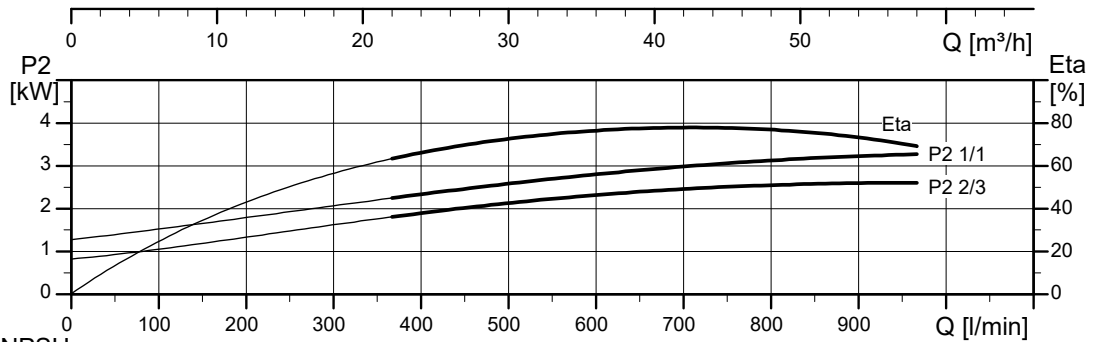
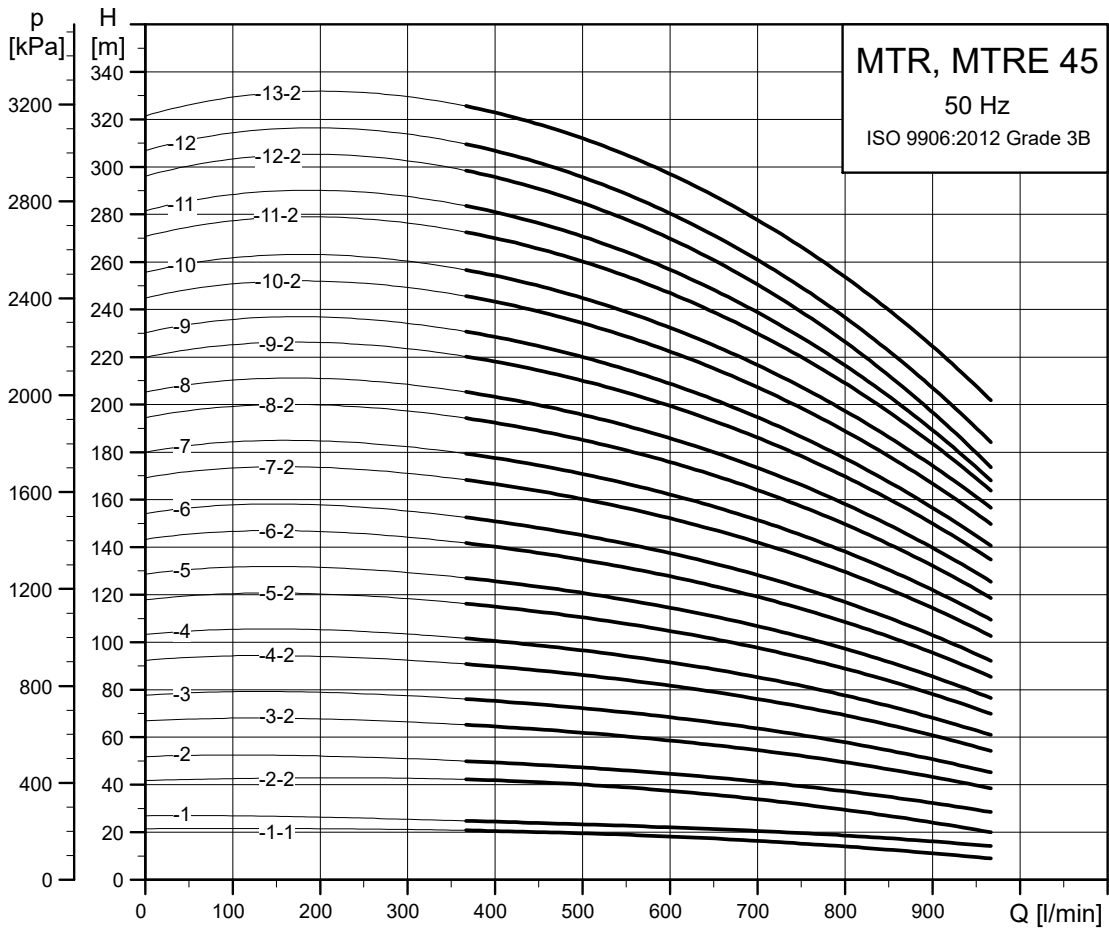

TMO14303

Dimensional sketches

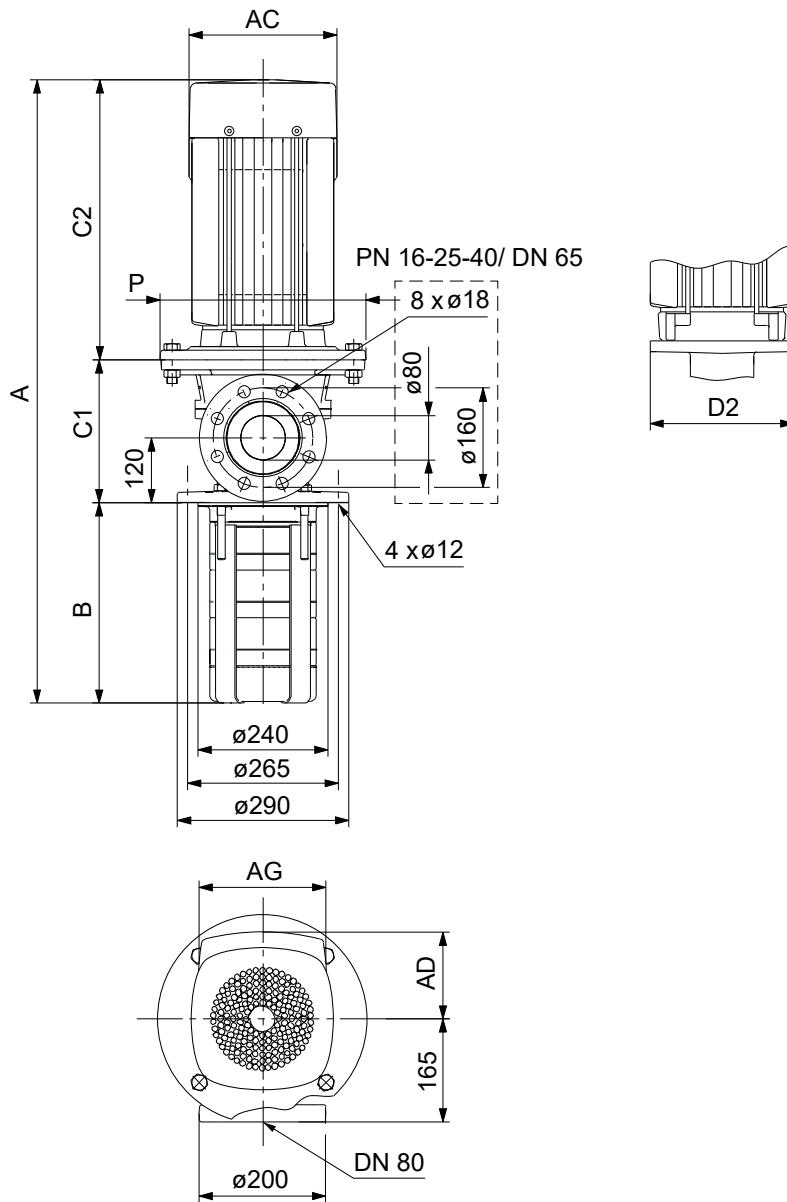

TM042792

Dimensions and weights

Pump type	P2 [kW]	MTR										MTRE											
		Dimensions [mm]										Net weight [kg]	Dimensions [mm]										Net weight [kg]
		A ¹²⁾	B	C1 ¹²⁾	C2	AC	D2	P	AD	AG	A ¹²⁾		B	C1 ¹²⁾	C2	AC	D2	P	AD	AG			
MTR, MTRE 45-2/1-1	3	748	244	169	335	198	198	-	120	162	70.9	747	244	169	334	191	198	-	201	291	70.8		
MTR, MTRE 45-2/1	4	785	244	169	372	220	198	-	134	202	82.6	747	244	169	334	191	198	-	201	291	73.9		
MTR, MTRE 45-2/2-2	5.5	875	244	240	391	220	298	300	134	202	96.3	849	244	240	365	191	298	300	201	291	91.6		
MTR, MTRE 45-2/2	7.5	863	244	240	379	260	298	300	159	203	106.1	873	244	240	389	255	298	300	237	346	101		
MTR 45-3/3-2	11	1046	324	240	482	318	350	350	204	243	144.4	-	-	-	-	-	-	-	-	-	-		
MTR, MTRE 45-3/3	11	1046	324	240	482	318	350	350	204	243	144.4	970	324	240	406	255	350	350	237	346	121.1		
MTR 45-4/4-2	15	1126	404	240	482	318	350	350	204	243	156.5	-	-	-	-	-	-	-	-	-	-		
MTR 45-4/4	15	1126	404	240	482	318	350	350	204	243	156.5	-	-	-	-	-	-	-	-	-	-		
MTR 45-5/5-2	18.5	1250	484	240	526	318	350	350	204	243	169.5	-	-	-	-	-	-	-	-	-	-		
MTR 45-5/5	18.5	1250	484	240	526	318	350	350	204	243	169.5	-	-	-	-	-	-	-	-	-	-		
MTR 45-6/6-2	22	1356	564	240	552	318	350	350	204	243	185	-	-	-	-	-	-	-	-	-	-		
MTR 45-6/6	22	1356	564	240	552	318	350	350	204	243	185	-	-	-	-	-	-	-	-	-	-		

Pump type	P2 [kW]	MTR										MTRE																
		Dimensions [mm]										Net weight [kg]	Dimensions [mm]										Net weight [kg]					
		A ¹²⁾	B	C1 ¹²⁾	C2	AC	D2	P	AD	AG	A ¹²⁾		B	C1 ¹²⁾	C2	AC	D2	P	AD	AG								
MTR 45-7/7-2	30	1495	644	240	611	396	400	400	315	265	285.1	-	-	-	-	-	-	-	-	-	-	-	-	-	-	-	-	-
MTR 45-7/7	30	1495	644	240	611	396	400	400	315	265	285.1	-	-	-	-	-	-	-	-	-	-	-	-	-	-	-	-	-
MTR 45-8/8-2	30	1575	724	240	611	396	400	400	315	265	285.4	-	-	-	-	-	-	-	-	-	-	-	-	-	-	-	-	-
MTR 45-8/8	30	1575	724	240	611	396	400	400	315	265	285.4	-	-	-	-	-	-	-	-	-	-	-	-	-	-	-	-	-
MTR 45-9/9-2	30	1655	804	240	611	396	400	400	315	265	285.7	-	-	-	-	-	-	-	-	-	-	-	-	-	-	-	-	-
MTR 45-9/9	37	1680	804	240	636	396	400	400	315	265	310.7	-	-	-	-	-	-	-	-	-	-	-	-	-	-	-	-	-
MTR 45-10/10-2	37	1760	884	240	636	396	400	400	315	265	311	-	-	-	-	-	-	-	-	-	-	-	-	-	-	-	-	-
MTR 45-10/10	37	1760	884	240	636	396	400	400	315	265	311	-	-	-	-	-	-	-	-	-	-	-	-	-	-	-	-	-
MTR 45-11/11-2	45	1931	964	259	708	449	450	450	338	266	413.7	-	-	-	-	-	-	-	-	-	-	-	-	-	-	-	-	-
MTR 45-11/11	45	1931	964	259	708	449	450	450	338	266	413.7	-	-	-	-	-	-	-	-	-	-	-	-	-	-	-	-	-
MTR 45-12/12-2	45	2011	1044	259	708	449	450	450	338	266	414	-	-	-	-	-	-	-	-	-	-	-	-	-	-	-	-	-
MTR 45-12/12	45	2011	1044	259	708	449	450	450	338	266	414	-	-	-	-	-	-	-	-	-	-	-	-	-	-	-	-	-
MTR 45-13/13-2	45	2091	1124	259	708	449	450	450	338	266	414.3	-	-	-	-	-	-	-	-	-	-	-	-	-	-	-	-	-

12)+20 mm for MTR, MTRE pumps with drainage back to the tank.

The maximum immersion depth is 1444 mm.

MTR, MTRE 64, 50 Hz

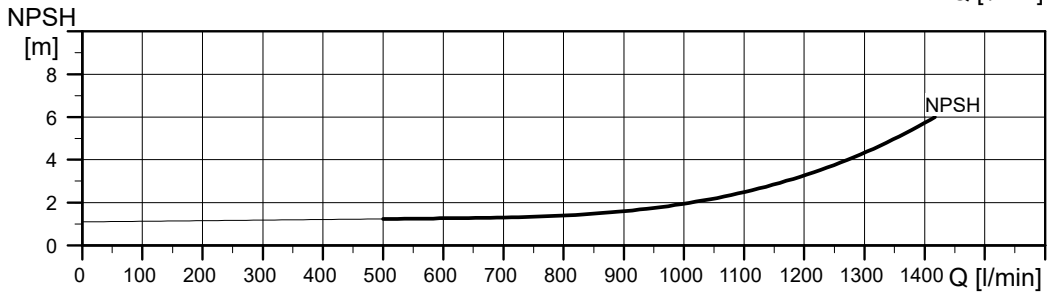
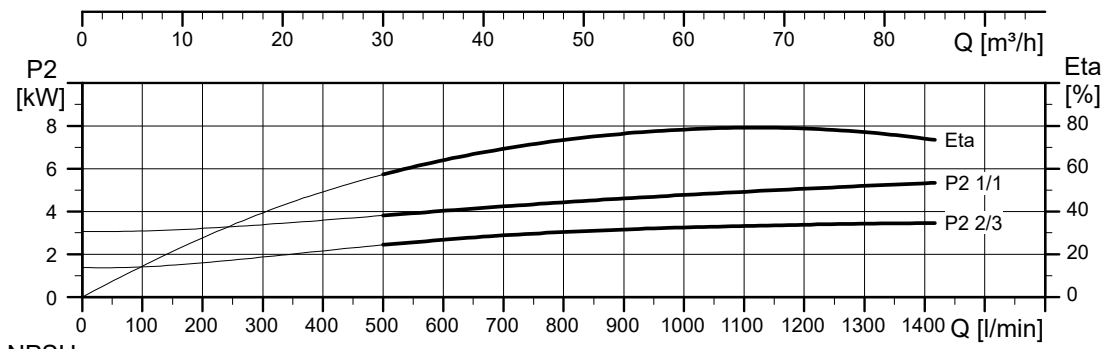
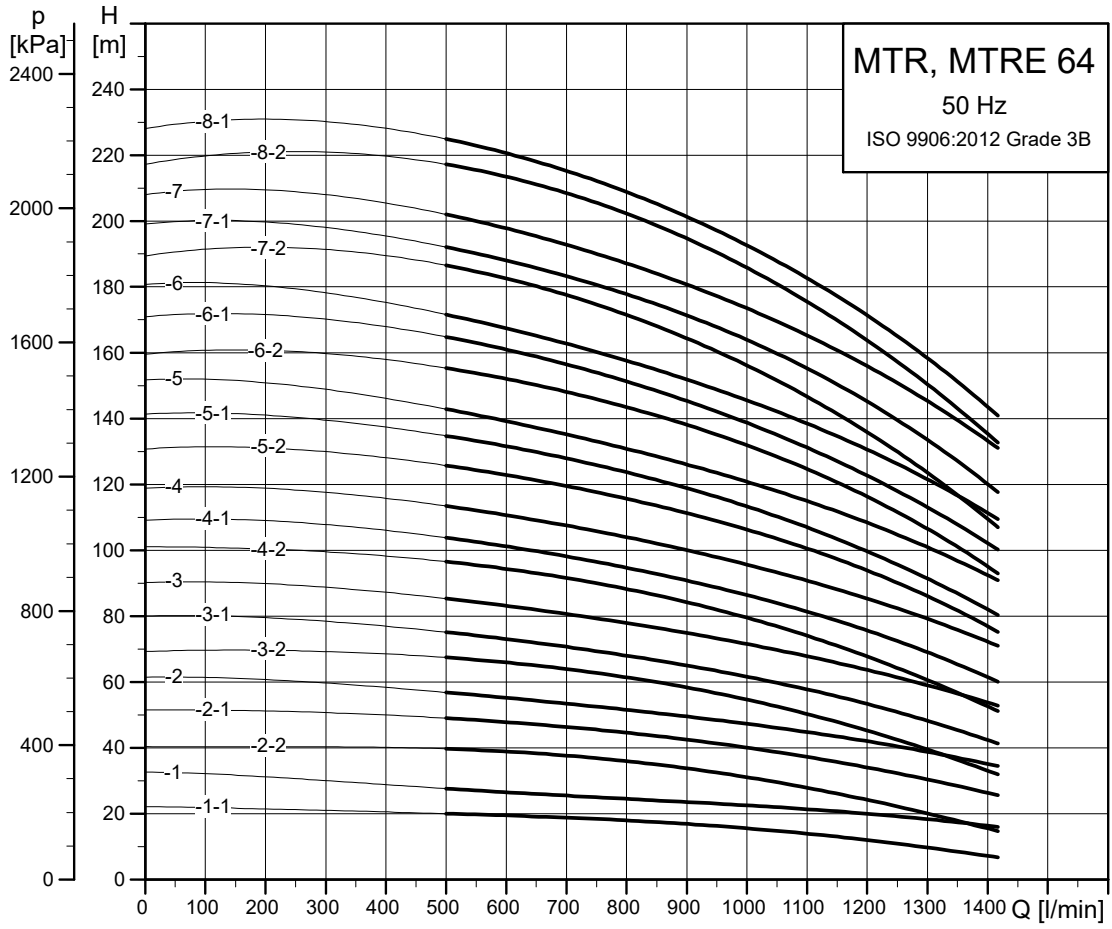

TM014304

Dimensional sketches

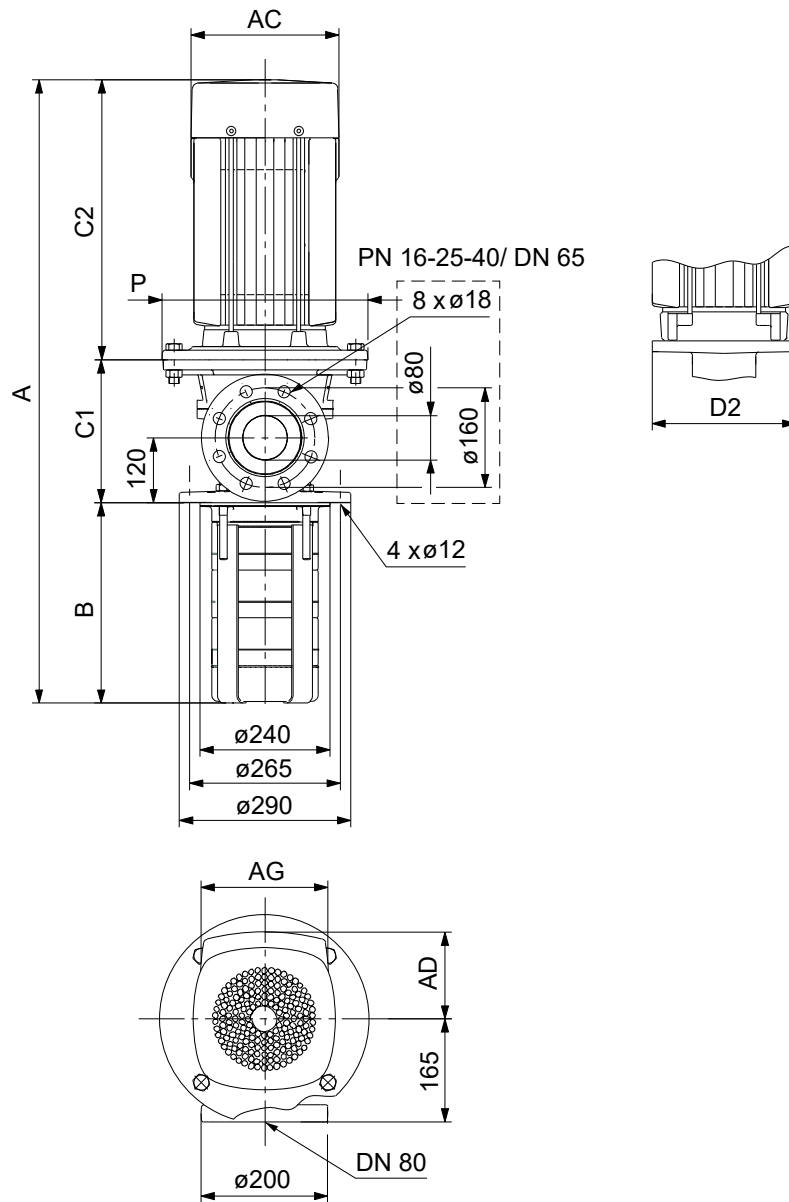

TM042792

Dimensions and weights

Pump type	P2 [kW]	MTR									MTRE										
		Dimensions [mm]									Net weight [kg]	Dimensions [mm]									Net weight [kg]
		A ¹³⁾	B	C1 ¹³⁾	C2	AC	D2	P	AD	AG		A ¹³⁾	B	C1 ¹³⁾	C2	AC	D2	P	AD	AG	
MTR, MTRE 64-2/1-1	4	790	249	169	372	220	198	-	134	202	85.7	752	249	169	334	191	198	-	201	291	76.9
MTR, MTRE 64-2/1	5.5	880	249	240	391	220	298	300	134	202	99.4	854	249	240	365	191	298	300	201	291	94.6
MTR, MTRE 64-2/2-2	7.5	868	249	240	379	260	298	300	159	203	109.2	878	249	240	389	255	298	300	237	346	104.0
MTR 64-2/2-1	11	971	249	240	482	318	350	350	204	243	147.2	-	-	-	-	-	-	-	-	-	-
MTR, MTRE 64-2/2	11	971	249	240	482	318	350	350	204	243	147.2	895	249	240	406	255	350	350	237	346	123.8
MTR 64-3/3-2	15	1054	332	240	482	318	350	350	204	243	159.3	-	-	-	-	-	-	-	-	-	-
MTR 64-3/3-1	15	1054	332	240	482	318	350	350	204	243	159.3	-	-	-	-	-	-	-	-	-	-
MTR 64-3/3	18.5	1098	332	240	526	318	350	350	204	243	172.0	-	-	-	-	-	-	-	-	-	-
MTR 64-4/4-2	18.5	1180	414	240	526	318	350	350	204	243	172.3	-	-	-	-	-	-	-	-	-	-
MTR 64-4/4-1	22	1206	414	240	552	318	350	350	204	243	187.5	-	-	-	-	-	-	-	-	-	-
MTR 64-4/4	22	1206	414	240	552	318	350	350	204	243	187.5	-	-	-	-	-	-	-	-	-	-
MTR 64-5/5-2	30	1348	497	240	611	396	400	400	315	265	287.6	-	-	-	-	-	-	-	-	-	-

Pump type	P2 [kW]	MTR										MTRE													
		Dimensions [mm]										Net weight [kg]	Dimensions [mm]										Net weight [kg]		
		A ¹³⁾	B	C1 ¹³⁾	C2	AC	D2	P	AD	AG	A ¹³⁾		B	C1 ¹³⁾	C2	AC	D2	P	AD	AG					
MTR 64-5/5-1	30	1348	497	240	611	396	400	400	315	265	287.6	-	-	-	-	-	-	-	-	-	-	-	-	-	-
MTR 64-5/5	30	1348	497	240	611	396	400	400	315	265	287.6	-	-	-	-	-	-	-	-	-	-	-	-	-	-
MTR 64-6/6-2	30	1430	579	240	611	396	400	400	315	265	287.9	-	-	-	-	-	-	-	-	-	-	-	-	-	-
MTR 64-6/6-1	37	1455	579	240	636	396	400	400	315	265	312.9	-	-	-	-	-	-	-	-	-	-	-	-	-	-
MTR 64-6/6	37	1455	579	240	636	396	400	400	315	265	312.9	-	-	-	-	-	-	-	-	-	-	-	-	-	-
MTR 64-7/7-2	37	1538	662	240	636	396	400	400	315	265	313.2	-	-	-	-	-	-	-	-	-	-	-	-	-	-
MTR 64-7/7-1	37	1538	662	240	636	396	400	400	315	265	313.2	-	-	-	-	-	-	-	-	-	-	-	-	-	-
MTR 64-7/7	45	1629	662	259	708	449	450	450	338	266	415.6	-	-	-	-	-	-	-	-	-	-	-	-	-	-
MTR 64-8/8-2	45	1711	744	259	708	449	450	450	338	266	415.9	-	-	-	-	-	-	-	-	-	-	-	-	-	-
MTR 64-8/8-1	45	1711	744	259	708	449	450	450	338	266	415.9	-	-	-	-	-	-	-	-	-	-	-	-	-	-

¹³⁾+20 mm for MTR, MTRE pumps with drainage back to the tank.

The maximum immersion depth is 1487 mm.

MTR, MTRE, 60 Hz

MTR, MTRE 1s, 60 Hz

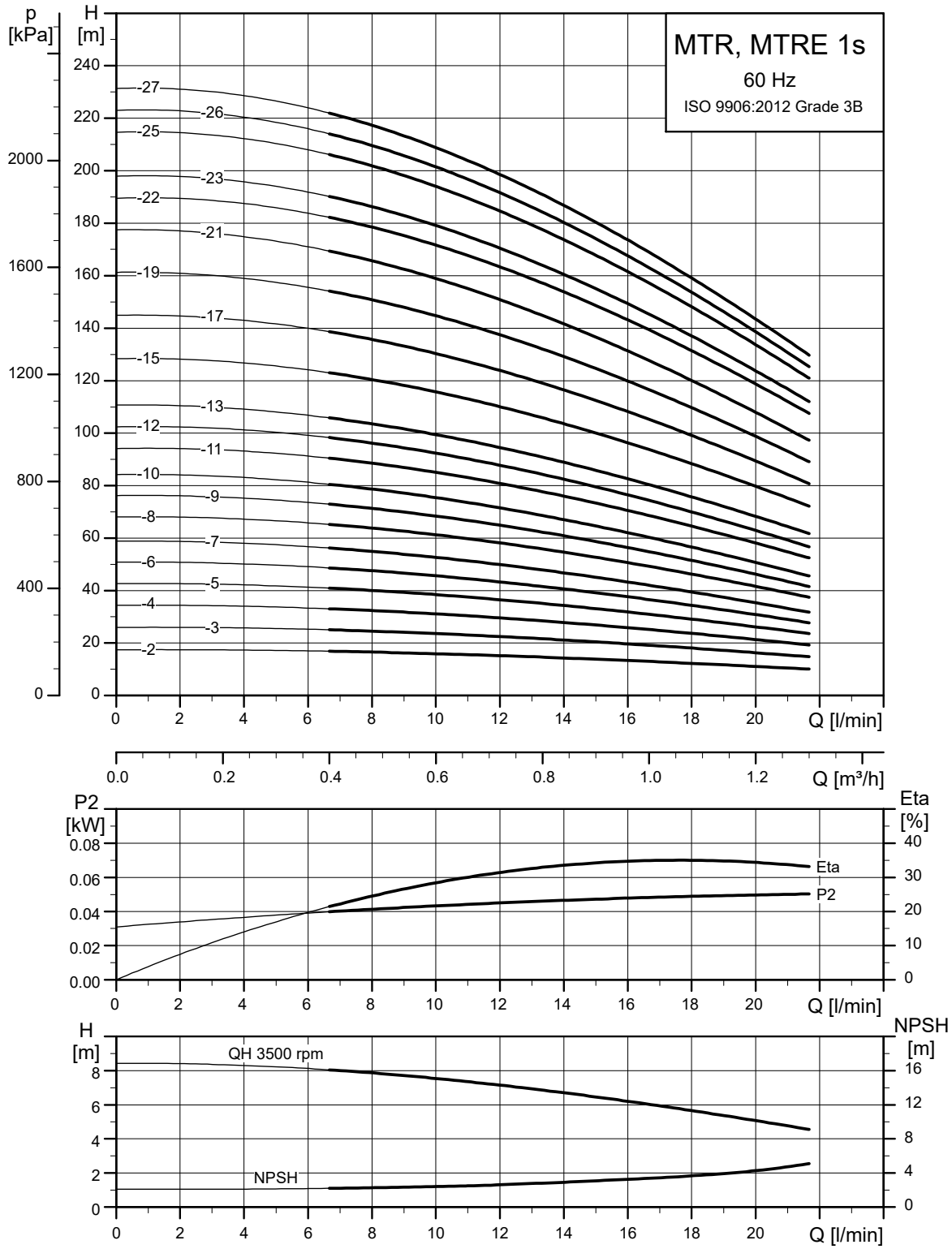

TM027846

Dimensional sketches

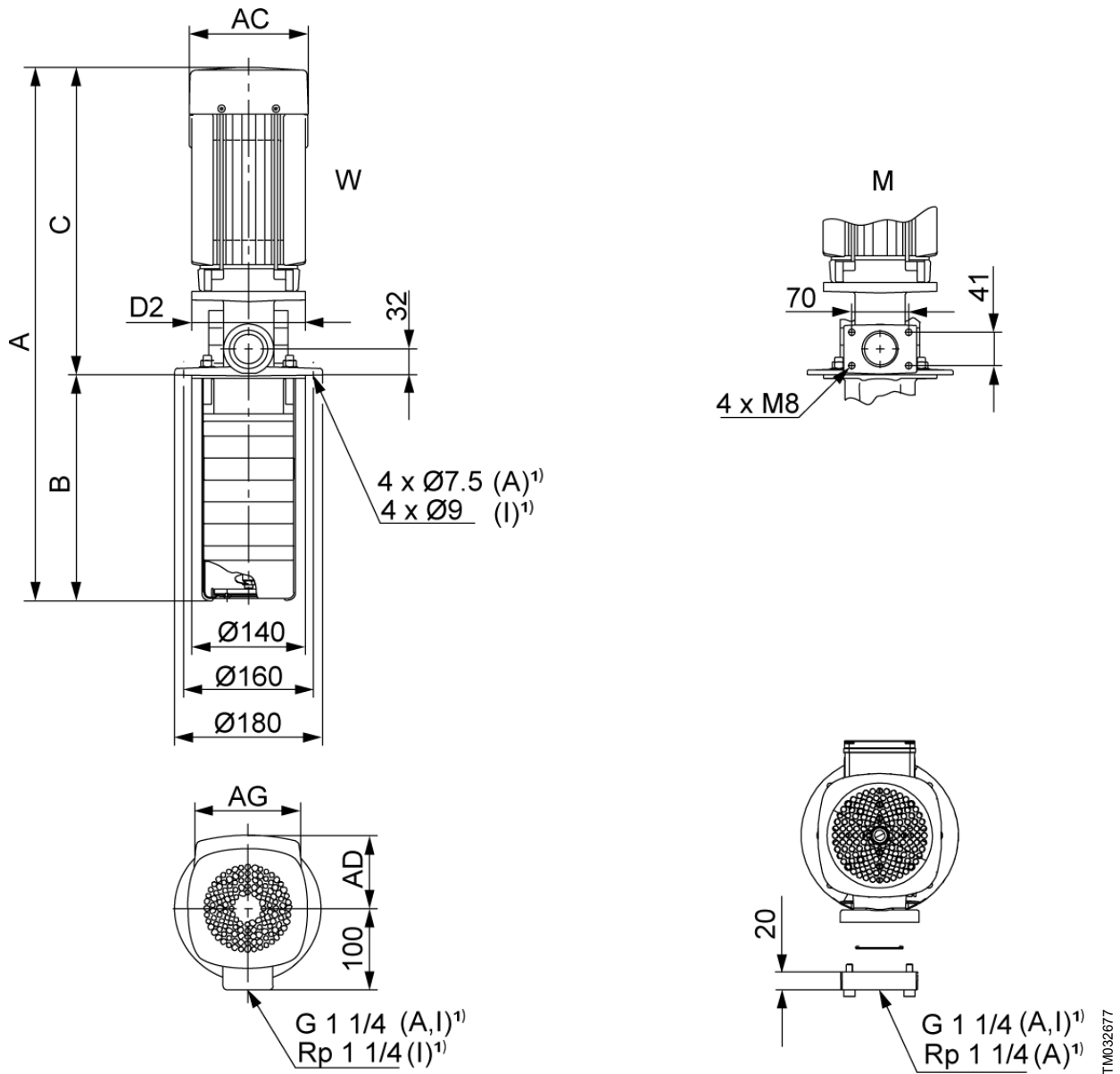

W: Internal thread connection. M: Square flange.

1) A: Basic version, cast iron. I: Stainless steel version.

Dimensions and weights

Pump type	P2 [kW]	MTR								Net weight [kg]	MTRE						
		Dimensions [mm]									Dimensions [mm]						
		A	B	C	AC	D2	AD	AG	A		B	C	AC	D2	AD	AG	
MTR 1s-2/2	0.37	462	160	302	141	140	109	82	12.93	-	-	-	-	-	-	-	-
MTR 1s-3/3	0.37	480	178	302	141	140	109	82	12.95	-	-	-	-	-	-	-	-
MTR, MTRE 1s-4/4	0.37	498	196	302	141	140	109	82	12.98	561	196	365	122	140	158	268	17.4
MTR 1s-5/5	0.37	516	214	302	141	140	109	82	13	-	-	-	-	-	-	-	-
MTR 1s-6/6	0.37	534	232	302	141	140	109	82	13.02	-	-	-	-	-	-	-	-
MTR, MTRE 1s-7/7	0.37	552	250	302	141	140	109	82	13.05	615	250	365	122	140	158	268	17.5
MTR 1s-8/8	0.55	570	268	302	141	140	109	82	12.53	-	-	-	-	-	-	-	-
MTR 1s-9/9	0.55	588	286	302	141	140	109	82	12.55	-	-	-	-	-	-	-	-
MTR, MTRE 1s-10/10	0.55	606	304	302	141	140	109	82	12.57	669	304	365	122	140	158	268	17.5
MTR 1s-11/11	0.75	664	322	342	141	140	109	82	14.88	-	-	-	-	-	-	-	-

TM032677

Pump type	P2 [kW]	MTR							Net weight [kg]	MTRE							Net weight [kg]			
		Dimensions [mm]								Dimensions [mm]										
		A	B	C	AC	D2	AD	AG		A	B	C	AC	D2	AD	AG				
MTR 1s-12/12	0.75	682	340	342	141	140	109	82	14.9	-	-	-	-	-	-	-	-	-	-	-
MTR, MTRE 1s-13/13	0.75	700	358	342	141	140	109	82	14.92	723	358	365	122	140	158	268	17.7			
MTR 1s-15/15	1.1	756	394	362	141	140	109	82	16.97	-	-	-	-	-	-	-	-	-	-	-
MTR 1s-17/17	1.1	792	430	362	141	140	109	82	17.01	-	-	-	-	-	-	-	-	-	-	-
MTR 1s-19/19	1.1	828	466	362	141	140	109	82	17.06	-	-	-	-	-	-	-	-	-	-	-
MTR, MTRE 1s-21/21	1.1	864	502	362	141	140	109	82	17.1	867	502	365	122	140	158	268	18.6			
MTR 1s-22/22	1.5	912	520	392	178	140	110	162	23.48	-	-	-	-	-	-	-	-	-	-	-
MTR, MTRE 1s-23/23	1.5	930	538	392	178	140	110	162	23.51	923	538	385	122	140	158	268	21.6			
MTR 1s-25/25	1.5	966	574	392	178	140	110	162	23.55	-	-	-	-	-	-	-	-	-	-	-
MTR 1s-26/26	1.5	984	592	392	178	140	110	162	23.57	-	-	-	-	-	-	-	-	-	-	-
MTR, MTRE 1s-27/27	1.5	1002	610	392	178	140	110	162	23.6	995	610	385	122	140	158	268	21.7			

The maximum immersion depth is 1006 mm.

MTR, MTRE 1, 60 Hz

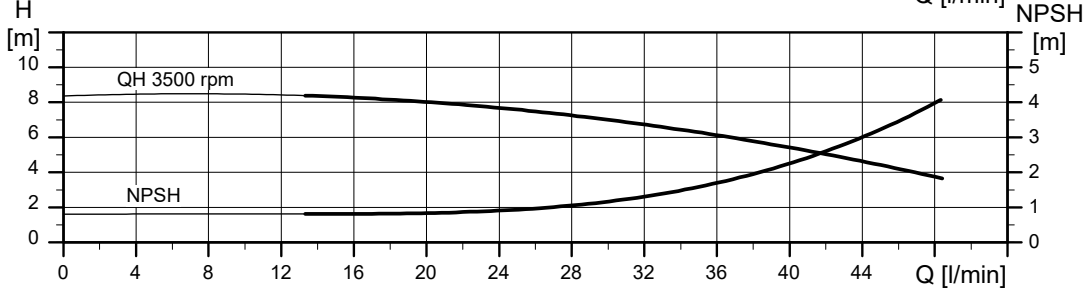
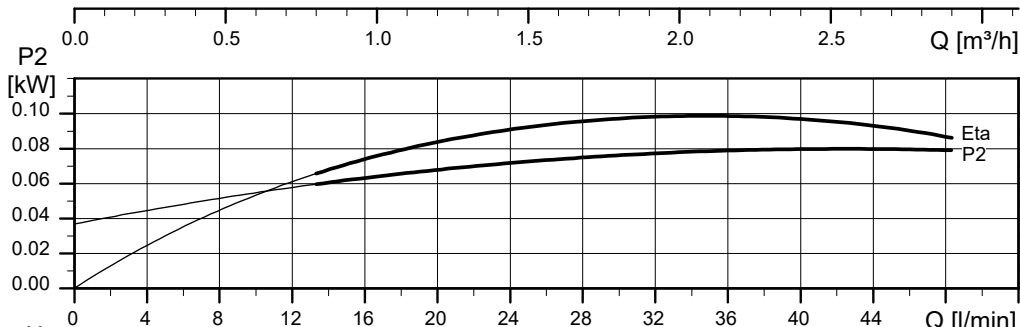
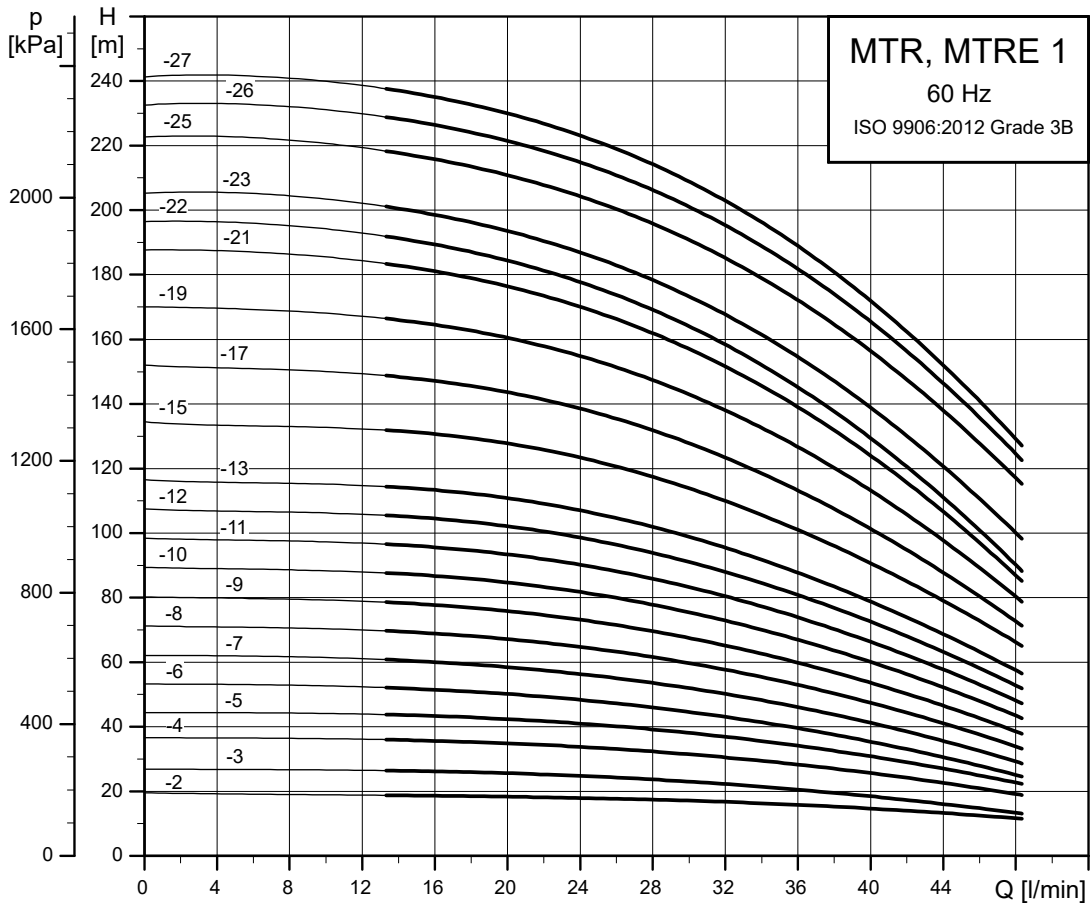

TM027847

Dimensional sketches

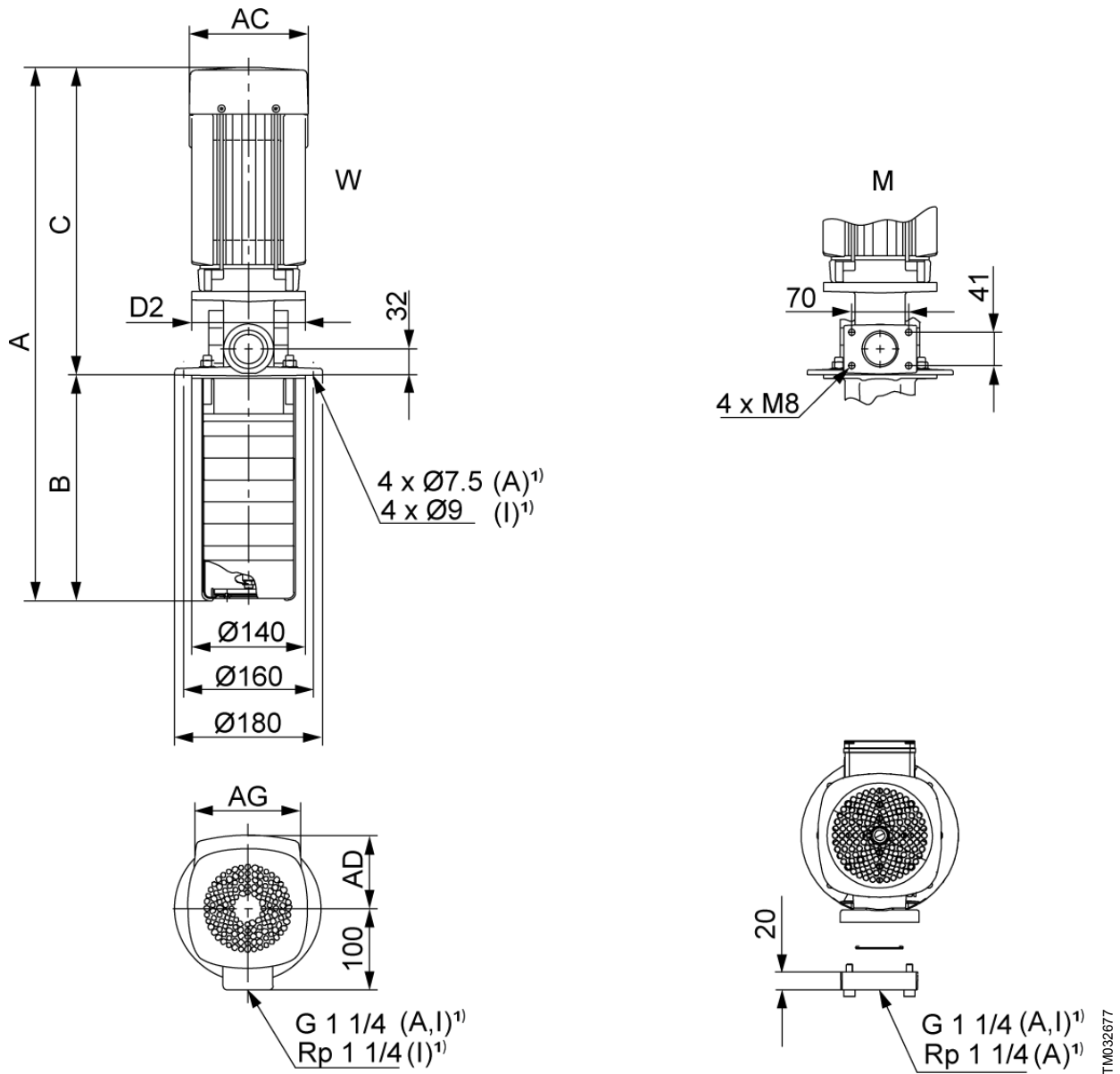

W: Internal thread connection. M: Square flange.

1) A: Basic version, cast iron. I: Stainless steel version.

Dimensions and weights

Pump type	P2 [kW]	MTR							Net weight [kg]	MTRE							
		Dimensions [mm]								Dimensions [mm]							
		A	B	C	AC	D2	AD	AG		A	B	C	AC	D2	AD	AG	
MTR 1-2/2	0.37	462	160	302	141	140	109	82	12.9	-	-	-	-	-	-	-	-
MTR 1-3/3	0.37	480	178	302	141	140	109	82	13	-	-	-	-	-	-	-	-
MTR, MTRE 1-4/4	0.37	498	196	302	141	140	109	82	13	561	196	365	122	140	158	268	17.4
MTR 1-5/5	0.55	516	214	302	141	140	109	82	12.5	-	-	-	-	-	-	-	-
MTR 1-6/6	0.55	534	232	302	141	140	109	82	12.5	-	-	-	-	-	-	-	-
MTR, MTRE 1-7/7	0.75	592	250	342	141	140	109	82	14.8	615	250	365	122	140	158	268	17.5
MTR 1-8/8	0.75	610	268	342	141	140	109	82	14.8	-	-	-	-	-	-	-	-
MTR, MTRE 1-9/9	0.75	628	286	342	141	140	109	82	14.8	651	286	365	122	140	158	268	17.6
MTR 1-10/10	1.1	666	304	362	141	140	109	82	16.9	-	-	-	-	-	-	-	-
MTR 1-11/11	1.1	684	322	362	141	140	109	82	16.9	-	-	-	-	-	-	-	-

TM032677

Pump type	P2 [kW]	MTR								MTRE								
		Dimensions [mm]							Net weight [kg]	Dimensions [mm]							Net weight [kg]	
		A	B	C	AC	D2	AD	AG		A	B	C	AC	D2	AD	AG		
MTR 1-12/12	1.1	702	340	362	141	140	109	82	16.9	-	-	-	-	-	-	-	-	-
MTR, MTRE 1-13/13	1.1	720	358	362	141	140	109	82	16.9	723	358	365	122	140	158	268	18.4	-
MTR 1-15/15	1.5	786	394	392	178	140	110	162	23.3	-	-	-	-	-	-	-	-	-
MTR, MTRE 1-17/17	1.5	822	430	392	178	140	110	162	23.4	815	430	385	122	140	158	268	21.4	-
MTR 1-19/19	2.2	898	466	432	178	140	110	162	27.2	-	-	-	-	-	-	-	-	-
MTR 1-21/21	2.2	934	502	432	178	140	110	162	27.3	-	-	-	-	-	-	-	-	-
MTR, MTRE 1-22/22	2.2	952	520	432	178	140	110	162	27.3	905	520	385	122	140	158	268	23	-
MTR 1-23/23	2.2	970	538	432	178	140	110	162	27.3	-	-	-	-	-	-	-	-	-
MTR 1-25/25	2.2	1006	574	432	178	140	110	162	27.4	-	-	-	-	-	-	-	-	-
MTR 1-26/26	3	1038	592	446	198	160	120	162	32.4	-	-	-	-	-	-	-	-	-
MTR, MTRE 1-27/27	3	1056	610	446	198	160	120	162	32.4	1055	610	445	191	160	201	291	32.3	-

The maximum immersion depth is 1006 mm.

MTR, MTRE 3, 60 Hz

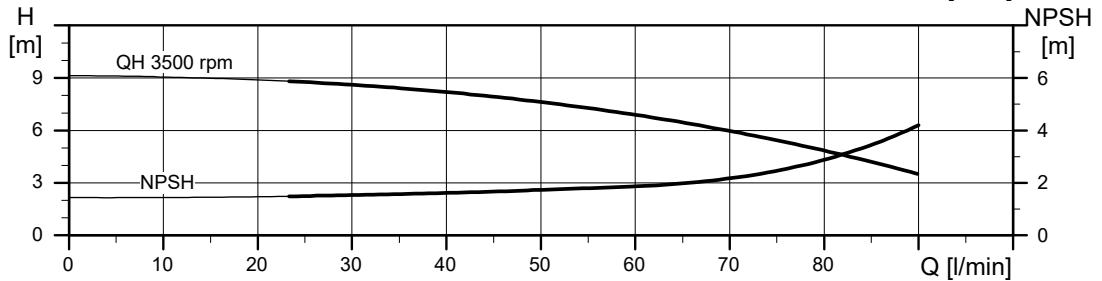
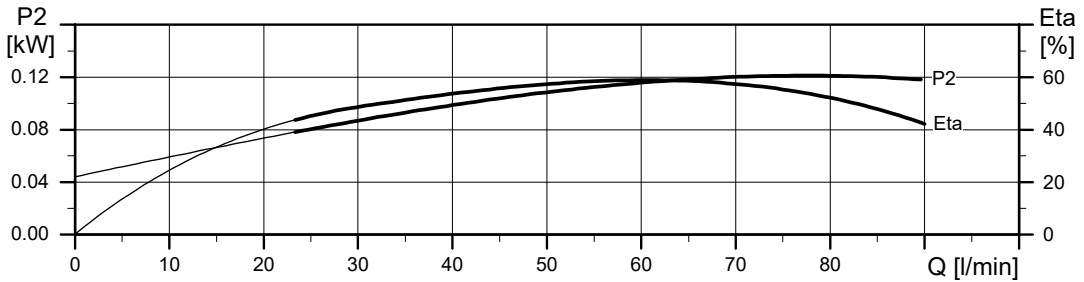
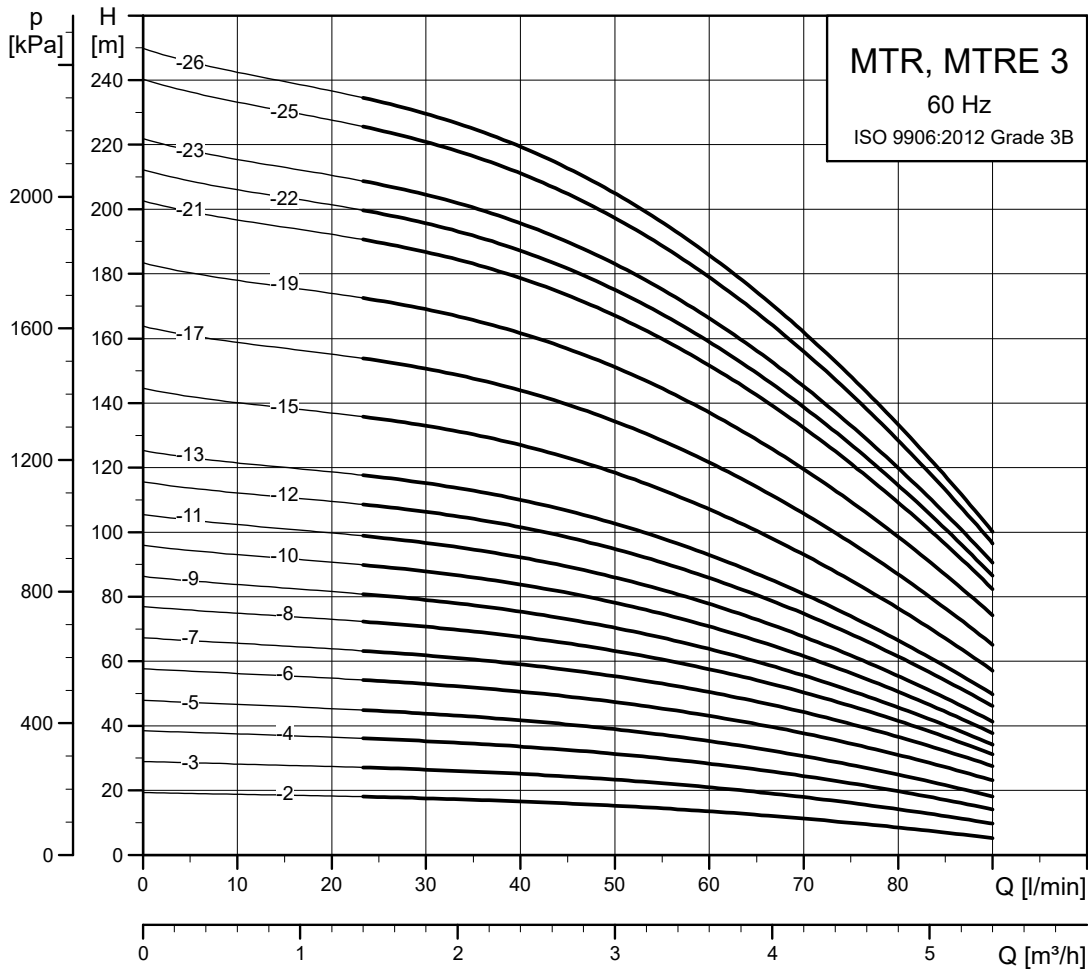

TM027848

Dimensional sketches

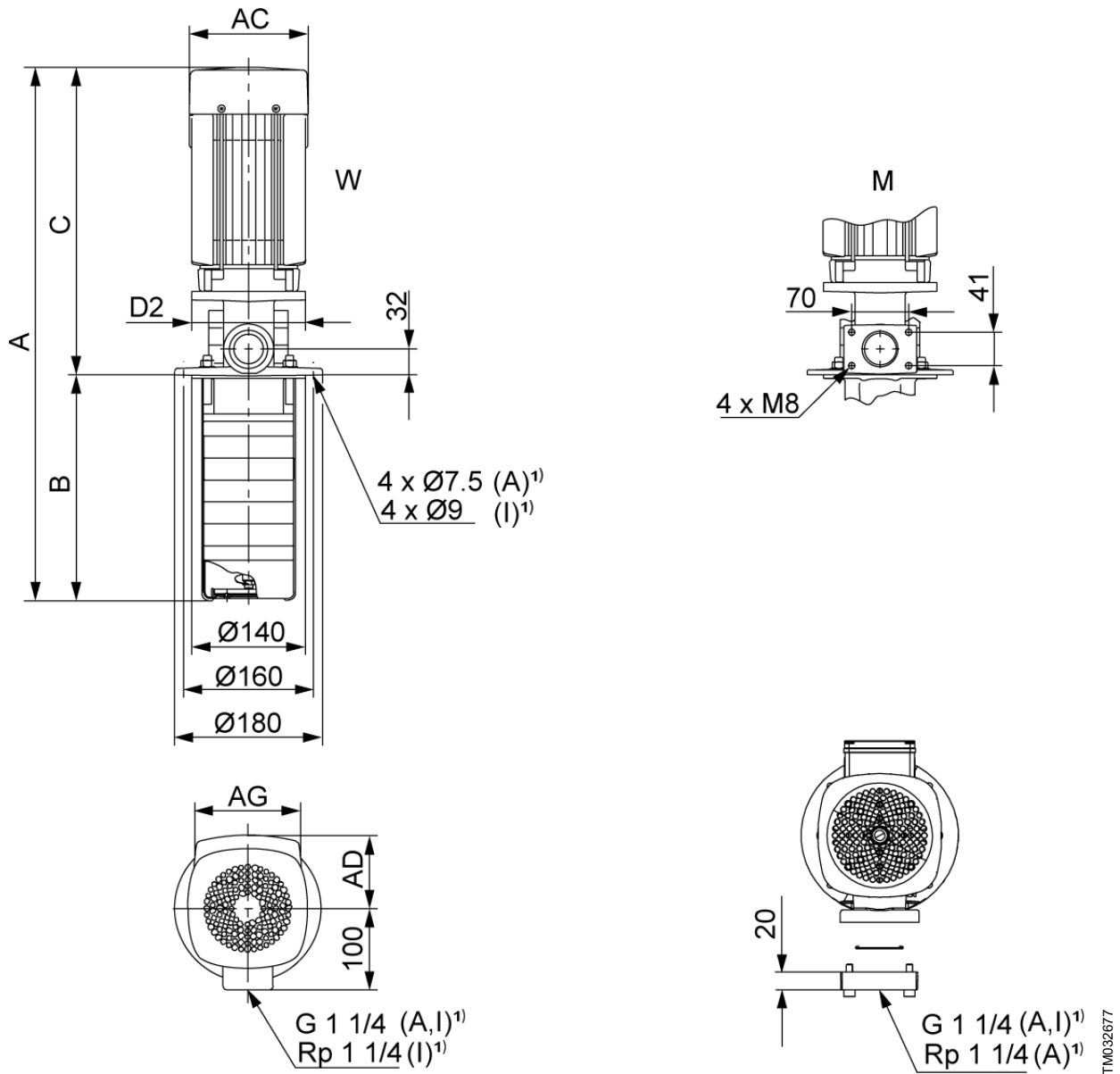

W: Internal thread connection. M: Square flange.

1) A: Basic version, cast iron. I: Stainless steel version.

Dimensions and weights

Pump type	P2 [kW]	MTR							Net weight [kg]	MTRE						Net weight [kg]	
		Dimensions [mm]								Dimensions [mm]							
		A	B	C	AC	D2	AD	AG		A	B	C	AC	D2	AD		AG
MTR 3-2/2	0.37	462	160	302	141	140	109	82	12.9	-	-	-	-	-	-	-	-
MTR, MTRE 3-3/3	0.55	480	178	302	141	140	109	82	12.4	543	178	365	122	140	158	268	17.4
MTR, MTRE 3-4/4	0.55	498	196	302	141	140	109	82	12.4	561	196	365	122	140	158	268	17.4
MTR 3-5/5	0.75	556	214	342	141	140	109	82	14.7	-	-	-	-	-	-	-	-
MTR, MTRE 3-6/6	1.1	594	232	362	141	140	109	82	16.8	597	232	365	122	140	158	268	18.3
MTR 3-7/7	1.1	612	250	362	141	140	109	82	16.8	-	-	-	-	-	-	-	-
MTR 3-8/8	1.1	630	268	362	141	140	109	82	16.8	-	-	-	-	-	-	-	-
MTR 3-9/9	1.5	678	286	392	178	140	110	162	23.2	-	-	-	-	-	-	-	-
MTR 3-10/10	1.5	696	304	392	178	140	110	162	23.2	-	-	-	-	-	-	-	-
MTR, MTRE 3-11/11	1.5	714	322	392	178	140	110	162	23.2	707	322	385	122	140	158	268	21.3

TM032677

Pump type	P2 [kW]	MTR								MTRE								
		Dimensions [mm]							Net weight [kg]	Dimensions [mm]							Net weight [kg]	
		A	B	C	AC	D2	AD	AG		A	B	C	AC	D2	AD	AG		
MTR 3-12/12	2.2	772	340	432	178	140	110	162	27.1	-	-	-	-	-	-	-	-	-
MTR 3-13/13	2.2	790	358	432	178	140	110	162	27.1	-	-	-	-	-	-	-	-	-
MTR 3-15/15	2.2	826	394	432	178	140	110	162	27.1	-	-	-	-	-	-	-	-	-
MTR, MTRE 3-17/17	2.2	862	430	432	178	140	110	162	27.2	815	430	385	122	140	158	268	22.8	
MTR 3-19/19	3	912	466	446	198	160	120	162	32.3	-	-	-	-	-	-	-	-	-
MTR 3-21/21	3	948	502	446	198	160	120	162	32.3	-	-	-	-	-	-	-	-	-
MTR 3-22/22	3	966	520	446	198	160	120	162	32.3	-	-	-	-	-	-	-	-	-
MTR, MTRE 3-23/23	3	984	538	446	198	160	120	162	32.4	983	538	445	191	160	201	291	32.2	
MTR 3-25/25	4	1057	574	483	220	160	134	202	44.1	-	-	-	-	-	-	-	-	-
MTR, MTRE 3-26/26	4	1075	592	483	220	160	134	202	44.1	1037	592	445	191	160	201	291	35.4	

The maximum immersion depth is 1006 mm.

MTR, MTRE 5, 60 Hz

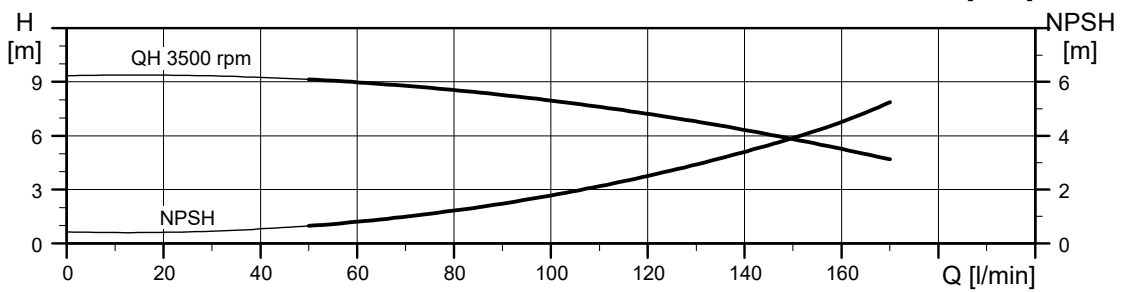
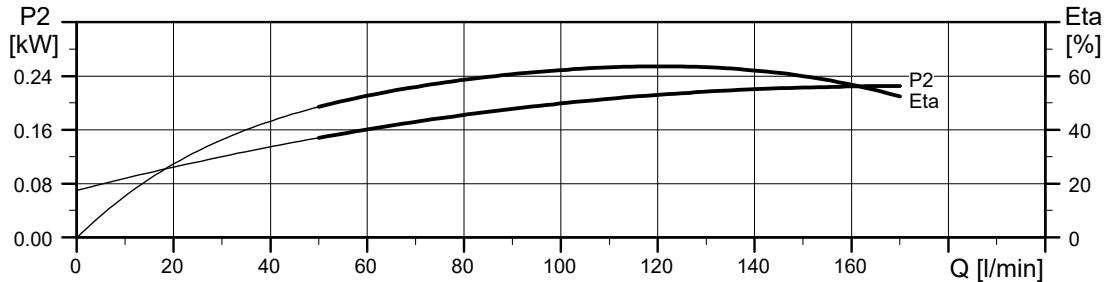
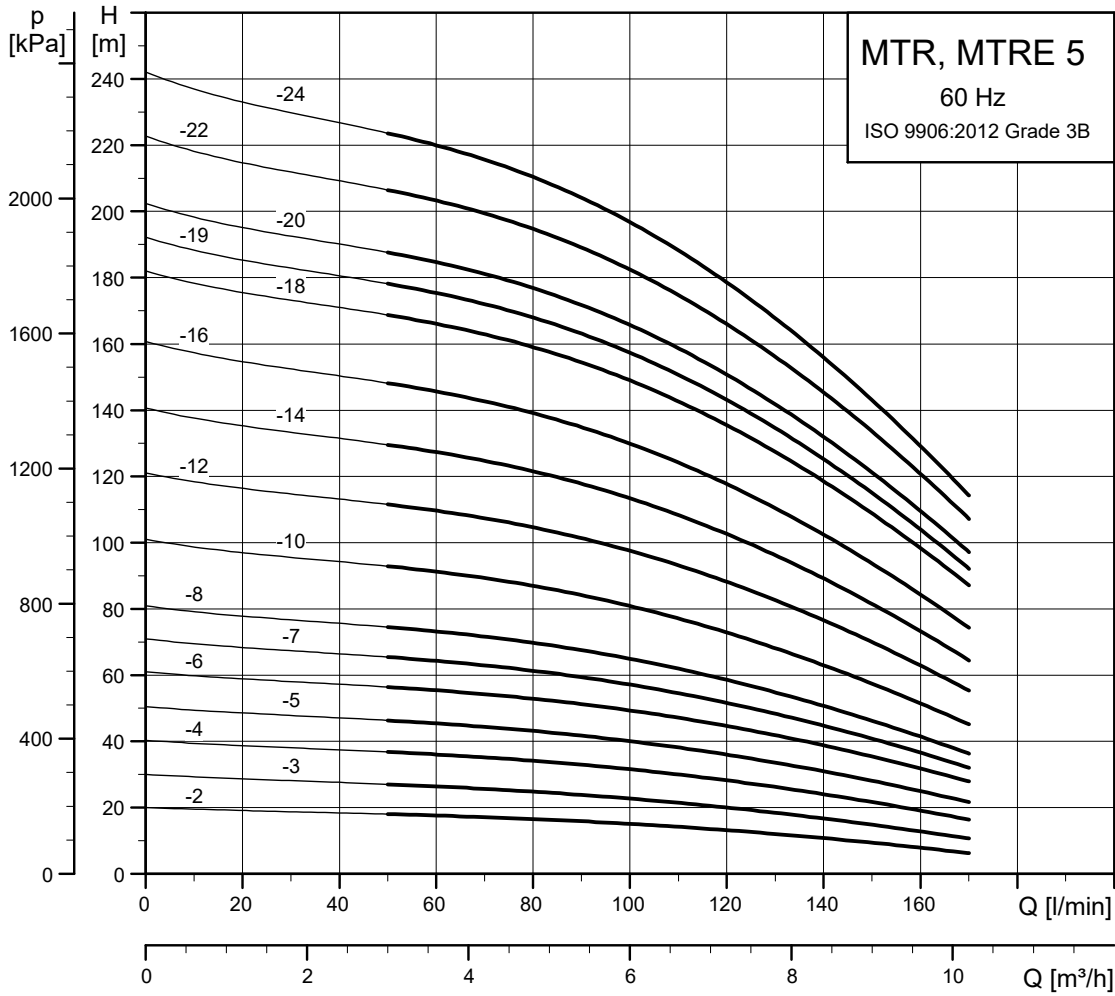

TM027849

Dimensional sketches

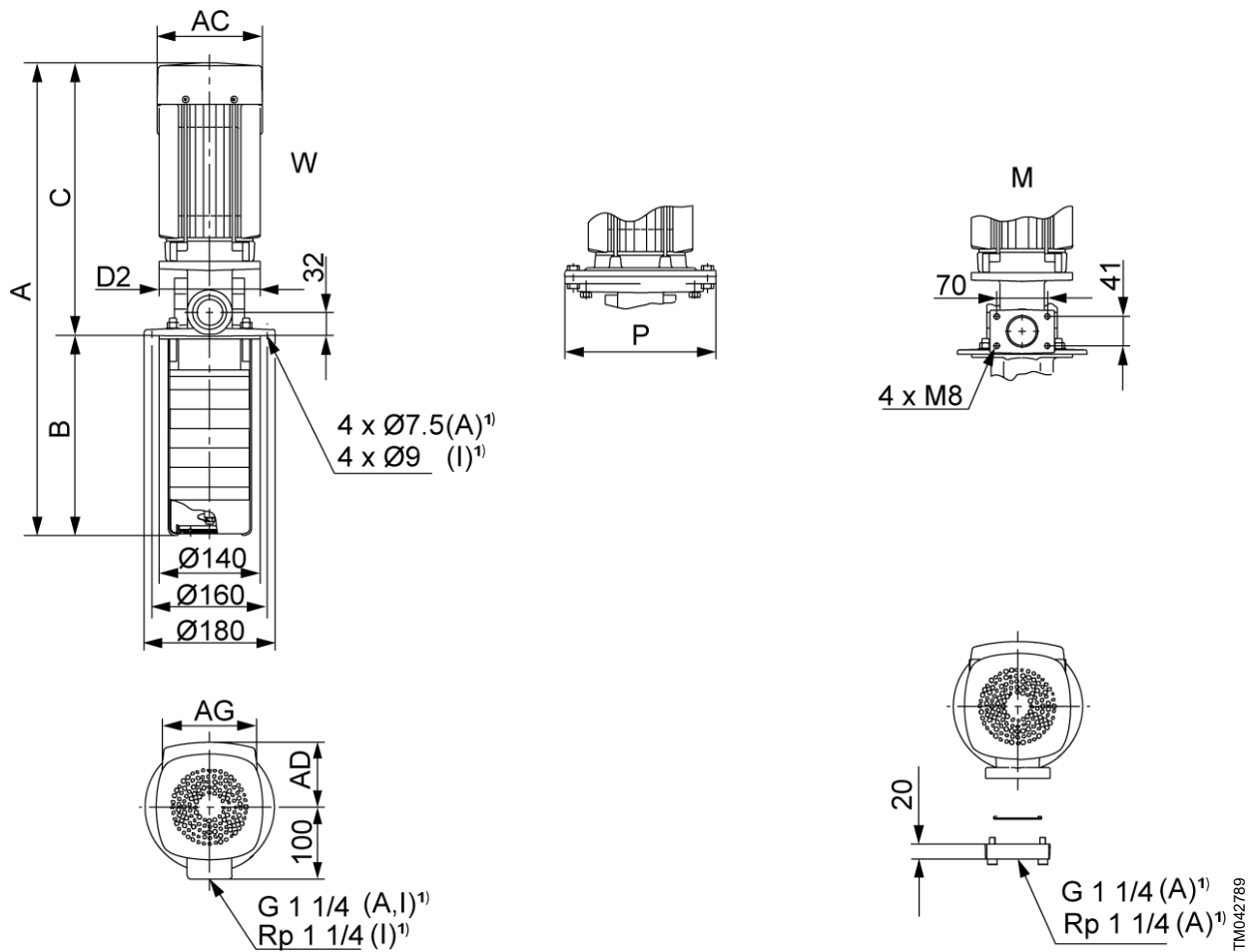

W: Internal thread connection. M: Square flange.

1) A: Basic version, cast iron. I: Stainless steel version.

Dimensions and weights

Pump type	P2 [kW]	MTR								Net weight [kg]	MTRE								
		Dimensions [mm]									Dimensions [mm]								
		A	B	C	AC	D2	P	AD	AG		A	B	C	AC	D2	P	AD	AG	
MTR, MTRE 5-2/2	0.55	471	169	302	141	140	-	109	82	12.7	534	169	365	122	140	-	158	268	17.6
MTR 5-3/3	1.1	558	196	362	141	140	-	109	82	17	-	-	-	-	-	-	-	-	-
MTR, MTRE 5-4/4	1.1	585	223	362	141	140	-	109	82	17	588	223	365	122	140	-	158	268	18.5
MTR, MTRE 5-5/5	1.5	642	250	392	178	140	-	110	162	23.4	635	250	385	122	140	-	158	268	21.5
MTR 5-6/6	2.2	709	277	432	178	140	-	110	162	27.3	-	-	-	-	-	-	-	-	-
MTR 5-7/7	2.2	736	304	432	178	140	-	110	162	27.3	-	-	-	-	-	-	-	-	-
MTR, MTRE 5-8/8	2.2	763	331	432	178	140	-	110	162	27.3	716	331	385	122	140	-	158	268	23
MTR 5-10/10	3	831	385	446	198	160	-	120	162	32.4	-	-	-	-	-	-	-	-	-
MTR, MTRE 5-12/12	3	885	439	446	198	160	-	120	162	32.5	884	439	445	191	160	-	201	291	32.4
MTR 5-14/14	4	976	493	483	220	160	-	134	202	44.3	-	-	-	-	-	-	-	-	-
MTR, MTRE 5-16/16	4	1030	547	483	220	160	-	134	202	44.3	992	547	445	191	160	-	201	291	35.6
MTR 5-18/18	5.5	1128	601	527	220	300	300	134	202	61.6	-	-	-	-	-	-	-	-	-
MTR 5-19/19	5.5	1155	628	527	220	300	300	134	202	61.6	-	-	-	-	-	-	-	-	-
MTR 5-20/20	5.5	1182	655	527	220	300	300	134	202	61.7	-	-	-	-	-	-	-	-	-
MTR, MTRE 5-22/22	5.5	1236	709	527	220	300	300	134	202	61.7	1210	709	501	191	300	300	201	291	57
MTR, MTRE 5-24/24	7.5	1278	763	515	260	300	300	159	203	71.6	1288	763	525	255	300	300	237	346	66.5

The maximum immersion depth is 1006 mm.

MTR, MTRE 8, 60 Hz

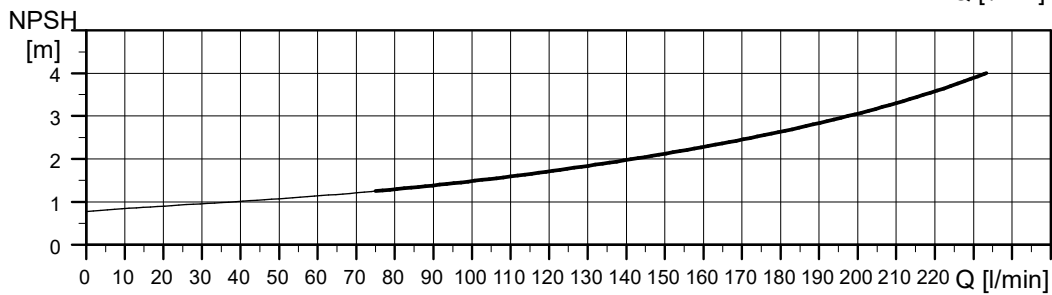
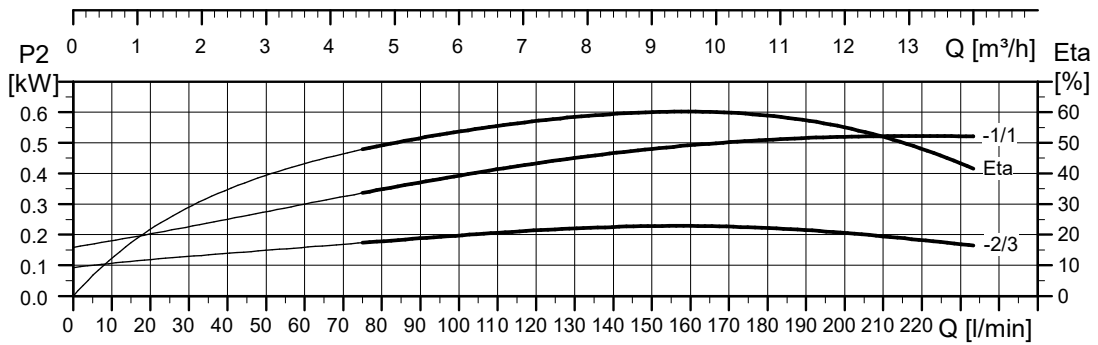
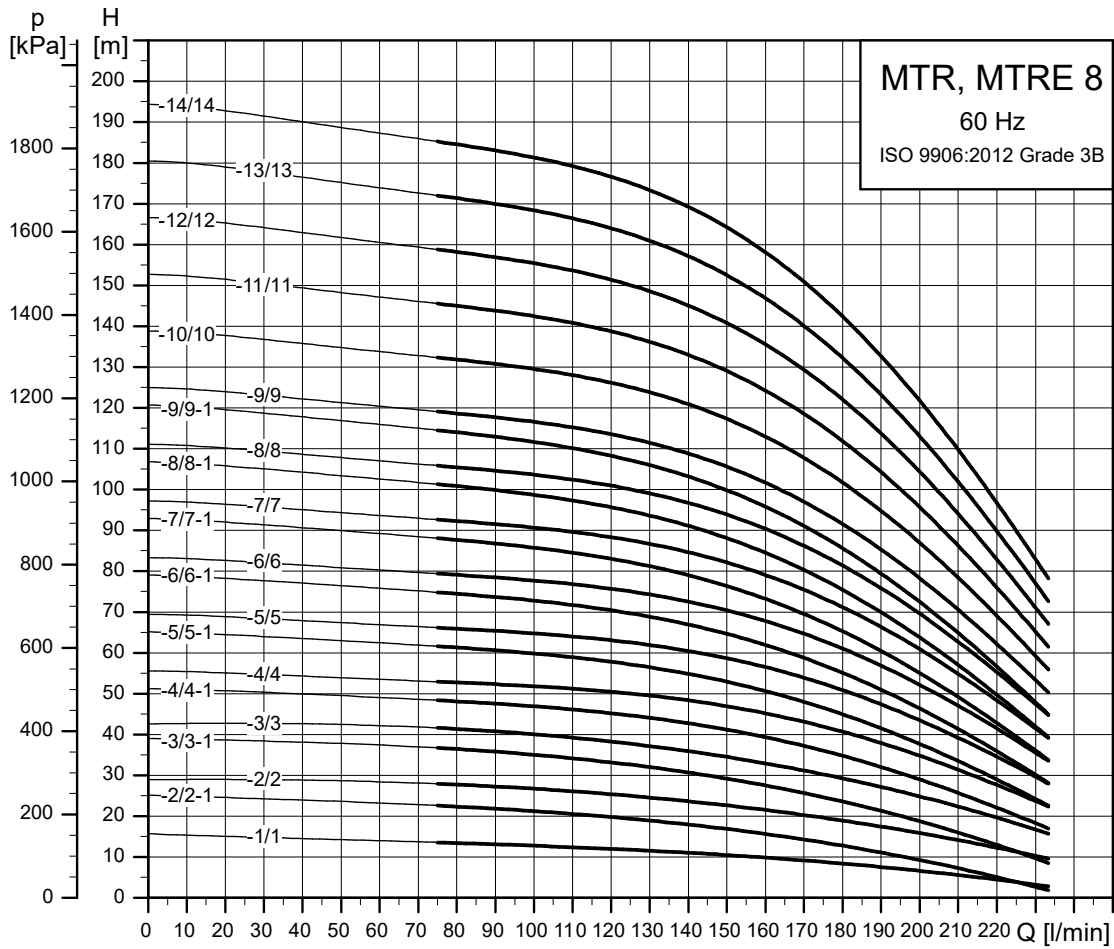

TM062364

Dimensional sketches

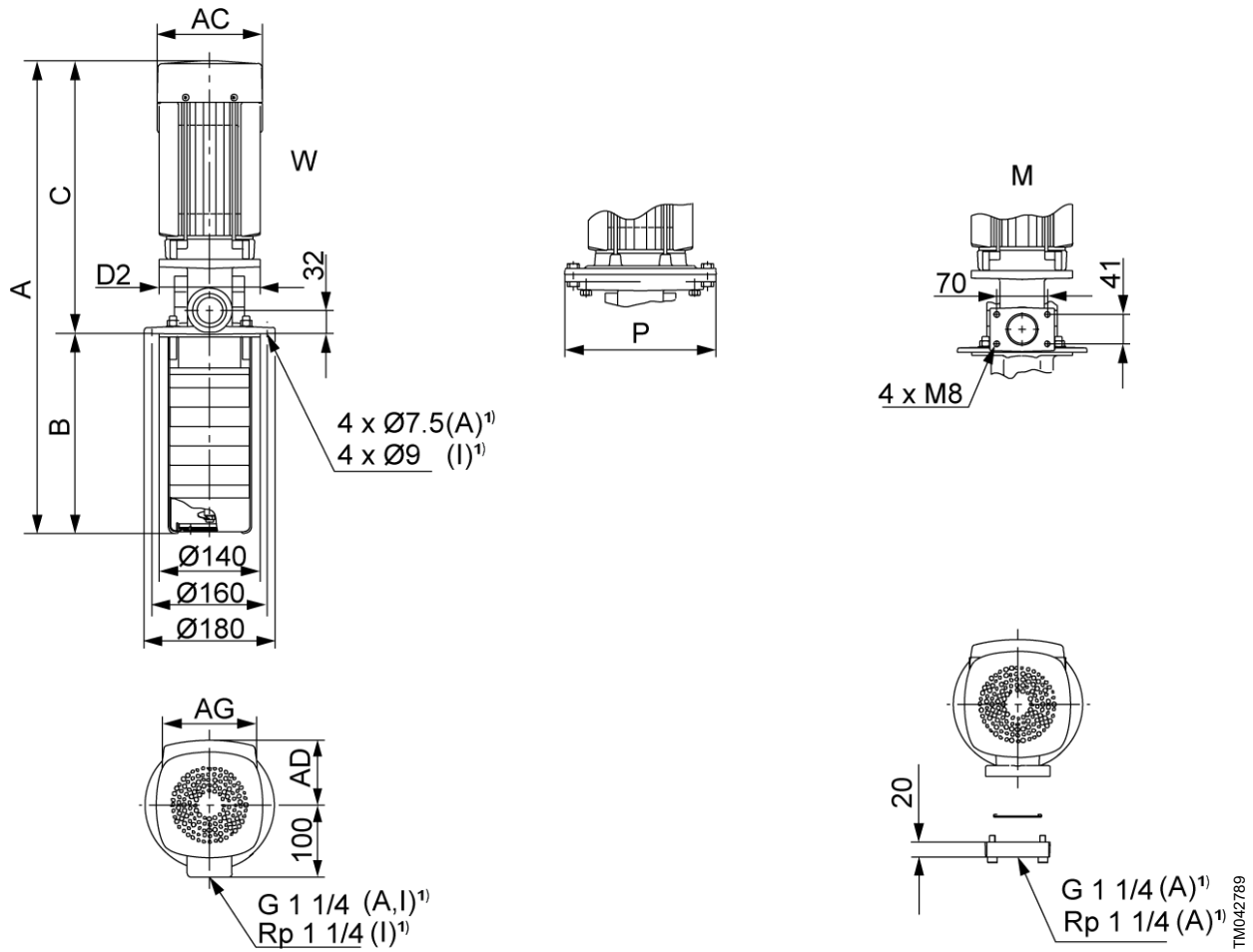

W: Internal thread connection. M: Square flange.

1) A: Basic version, cast iron. I: Stainless steel version.

Dimensions and weights

Pump type	P2 [kW]	MTR								Net weight [kg]	MTRE								
		Dimensions [mm]									Dimensions [mm]								
		A	B	C	AC	D2	P	AD	AG		A	B	C	AC	D2	P	AD	AG	
MTR, MTRE 8-1/1	0.75	538	196	342	141	140	-	109	82	19.3	561	196	365	122	140	-	158	268	22.1
MTR, MTRE 8-2/2-1	1.1	585	223	362	141	140	-	109	82	21.4	588	223	365	122	140	-	158	268	22.9
MTR, MTRE 8-2/2	1.1	585	223	362	141	140	-	109	82	21.4	588	223	365	122	140	-	158	268	22.9
MTR, MTRE 8-3/3-1	1.5	642	250	392	178	140	-	110	162	27.8	635	250	385	122	140	-	158	268	25.8
MTR 8-3/3	2.2	682	250	432	178	140	-	110	162	31.6	-	-	-	-	-	-	-	-	-
MTR 8-4/4-1	2.2	709	277	432	178	140	-	110	162	31.6	-	-	-	-	-	-	-	-	-
MTR, MTRE 8-4/4	2.2	709	277	432	178	140	-	110	162	31.6	662	277	385	122	140	-	158	268	27.2
MTR 8-5/5-1	3	750	304	446	198	160	-	120	162	36.7	-	-	-	-	-	-	-	-	-
MTR 8-5/5	3	750	304	446	198	160	-	120	162	36.7	-	-	-	-	-	-	-	-	-
MTR, MTRE 8-6/6-1	3	777	331	446	198	160	-	120	162	36.7	776	331	445	191	160	-	201	291	36.6
MTR 8-6/6	4	814	331	483	220	160	-	134	202	48.4	-	-	-	-	-	-	-	-	-
MTR 8-7/7-1	4	841	358	483	220	160	-	134	202	48.4	-	-	-	-	-	-	-	-	-
MTR 8-7/7	4	841	358	483	220	160	-	134	202	48.4	-	-	-	-	-	-	-	-	-
MTR, MTRE 8-8/8-1	4	868	385	483	220	160	-	134	202	48.5	830	385	445	191	160	-	201	291	39.7
MTR 8-8/8	5.5	912	385	527	220	300	300	134	202	65.7	-	-	-	-	-	-	-	-	-
MTR 8-9/9-1	5.5	939	412	527	220	300	300	134	202	65.7	-	-	-	-	-	-	-	-	-
MTR 8-9/9	5.5	939	412	527	220	300	300	134	202	65.7	-	-	-	-	-	-	-	-	-
MTR, MTRE 8-10/10	5.5	966	439	527	220	300	300	134	202	65.7	940	439	501	191	300	300	201	291	61

Pump type	P2 [kW]	MTR									MTRE										
		Dimensions [mm]									Net weight [kg]	Dimensions [mm]									Net weight [kg]
		A	B	C	AC	D2	P	AD	AG	A		B	C	AC	D2	P	AD	AG			
MTR 8-11/11	7.5	981	466	515	260	300	300	159	203	75.6	-	-	-	-	-	-	-	-	-	-	
MTR 8-12/12	7.5	1008	493	515	260	300	300	159	203	75.6	-	-	-	-	-	-	-	-	-	-	
MTR 8-13/13	7.5	1035	520	515	260	300	300	159	203	75.6	-	-	-	-	-	-	-	-	-	-	
MTR, MTRE 8-14/14	7.5	1062	547	515	260	300	300	159	203	75.7	1072	547	525	255	300	300	237	346	70.5		

The maximum immersion depth is 1006 mm.

MTR, MTRE 10, 60 Hz

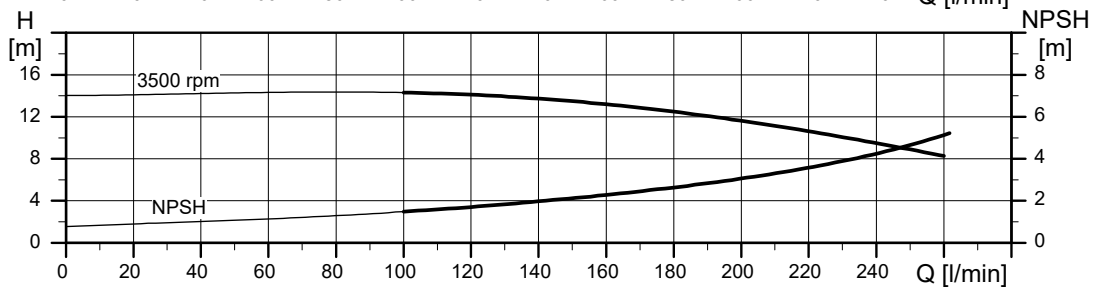
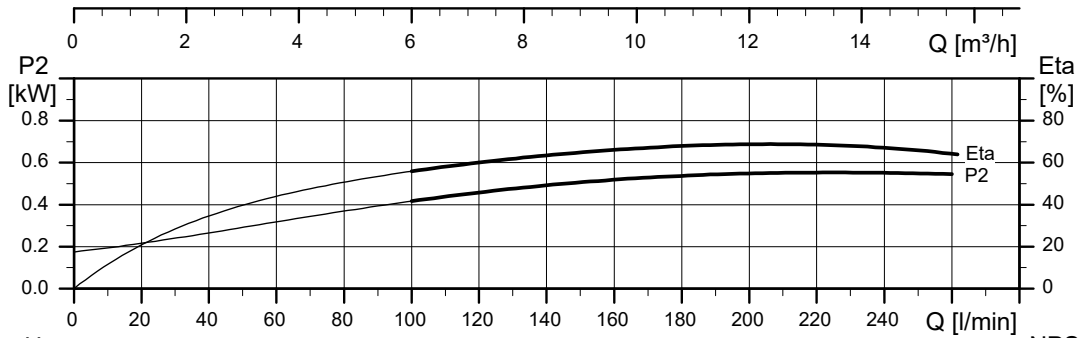
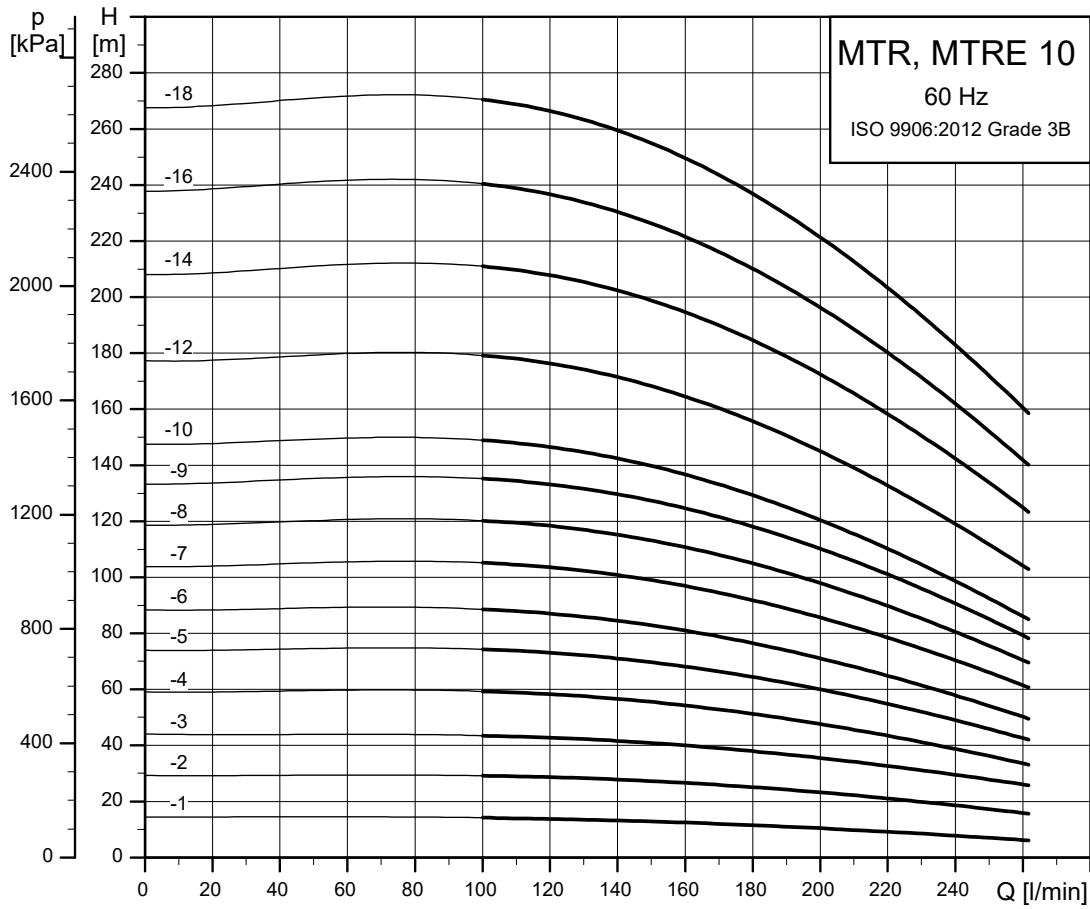

TM027850

Dimensional sketches

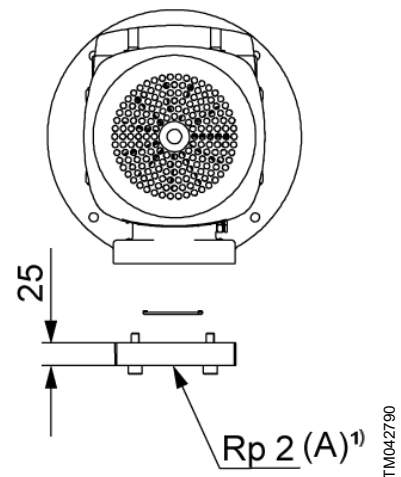
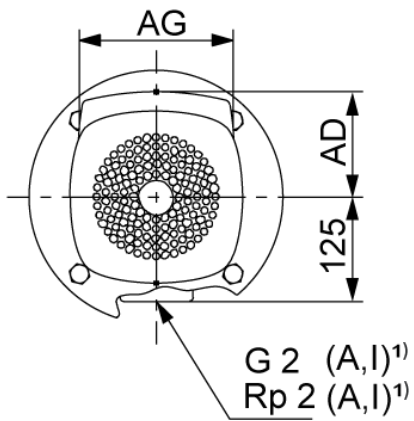
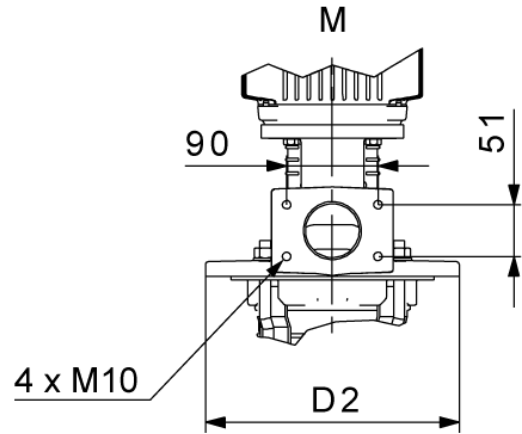
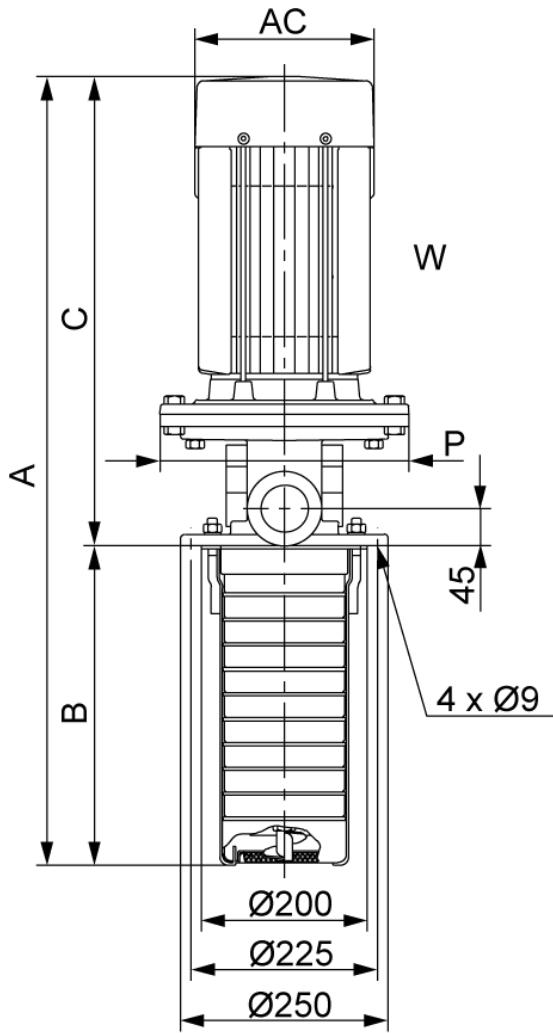

W: Internal thread connection. M: Square flange.

1) A: Basic version, cast iron. I: Stainless steel version.

TM042790

MTR, MTRE 15, 60 Hz

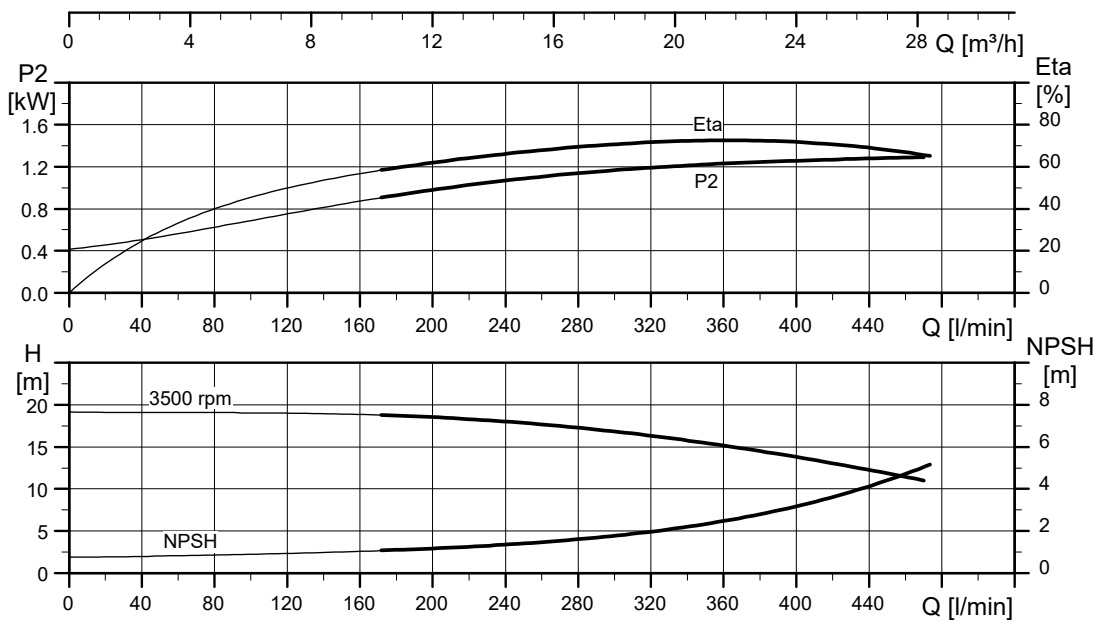
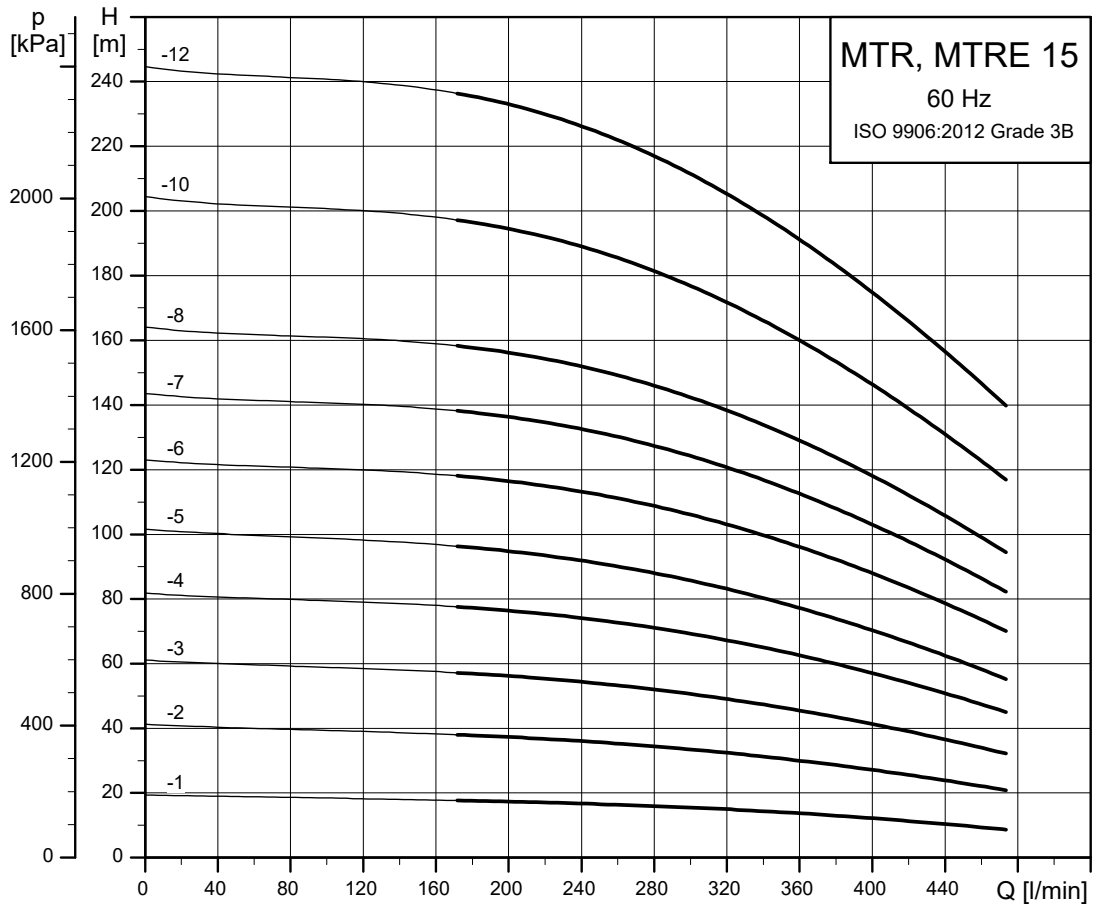

TM027851

Dimensional sketches

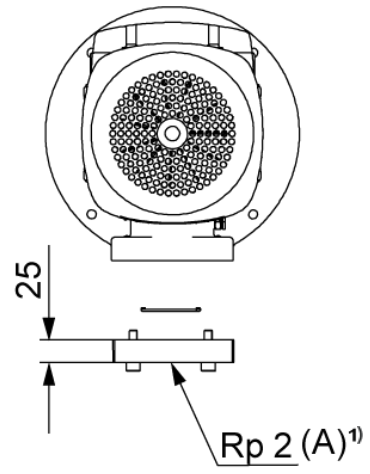
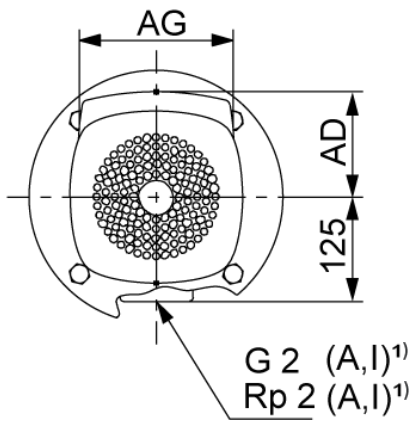
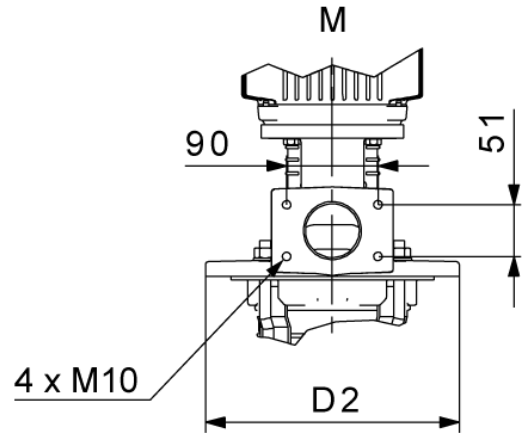
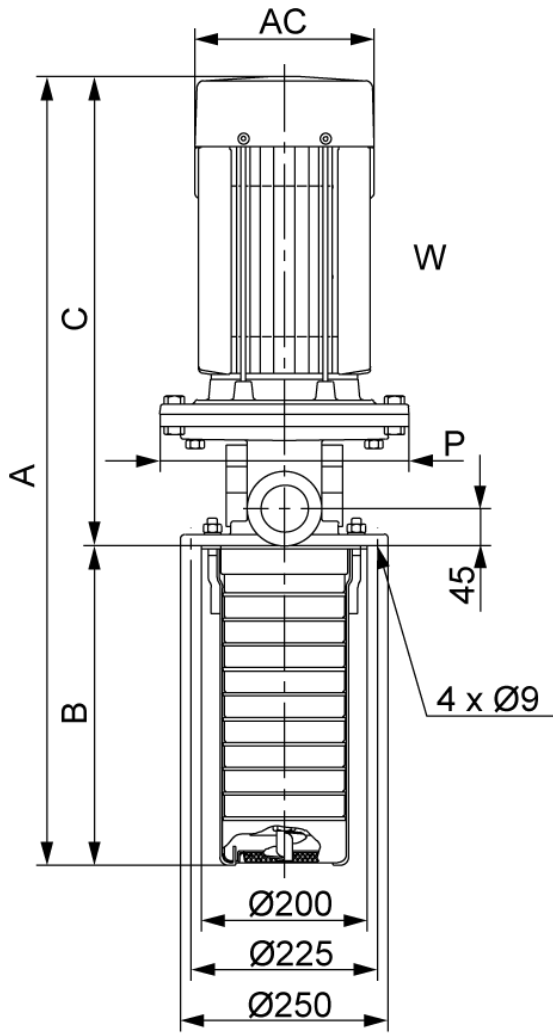

TM042790

W: Internal thread connection. M: Square flange.

1) A: Basic version, cast iron. I: Stainless steel version.

Dimensions and weights

Pump type	P2 [kW]	MTR									MTRE									
		Dimensions [mm]									Net weight [kg]	Dimensions [mm]								Net weight [kg]
		A	B	C	AC	D2	P	AD	AG	A		B	C	AC	D2	P	AD	AG		
MTR, MTRE 15-2/1	1.5	599	178	421	178	140	-	110	162	32.1	592	178	414	122	140	-	158	268	30.2	
MTR, MTRE 15-2/2	3	653	178	475	198	160	-	120	162	41	652	178	474	191	160	-	201	291	40.8	
MTR, MTRE 15-3/3	4	735	223	512	220	160	-	134	202	52.8	697	223	474	191	160	-	201	291	44	
MTR, MTRE 15-4/4	5.5	823	268	555	220	300	300	134	202	65.1	797	268	529	191	300	300	201	291	60.4	
MTR, MTRE 15-5/5	7.5	856	313	543	260	300	300	159	203	75	866	313	553	255	300	300	237	346	69.9	
MTR 15-6/6	11	1034	358	676	318	350	350	204	243	112.6	-	-	-	-	-	-	-	-	-	
MTR 15-7/7	11	1079	403	676	318	350	350	204	243	112.7	-	-	-	-	-	-	-	-	-	
MTR, MTRE 15-8/8	11	1124	448	676	318	350	350	204	243	112.8	1048	448	600	255	350	350	237	346	89.4	
MTR, MTRE 15-10/10	15	1214	538	676	318	350	350	204	243	124.8	1214	538	676	318	350	350	303	420	107.6	
MTR, MTRE 15-12/12	18.5	1348	628	720	318	350	350	204	243	137.7	1304	628	720	318	350	350	303	420	112.3	
MTR 15-14/12	18.5	1438	718	720	318	350	350	204	243	137.9	-	-	-	-	-	-	-	-	-	
MTR 15-16/12	18.5	1528	808	720	318	350	350	204	243	138.1	-	-	-	-	-	-	-	-	-	
MTR 15-17/12	18.5	1573	853	720	318	350	350	204	243	138.2	-	-	-	-	-	-	-	-	-	

The maximum immersion depth is 1033 mm.

MTR, MTRE 20, 60 Hz

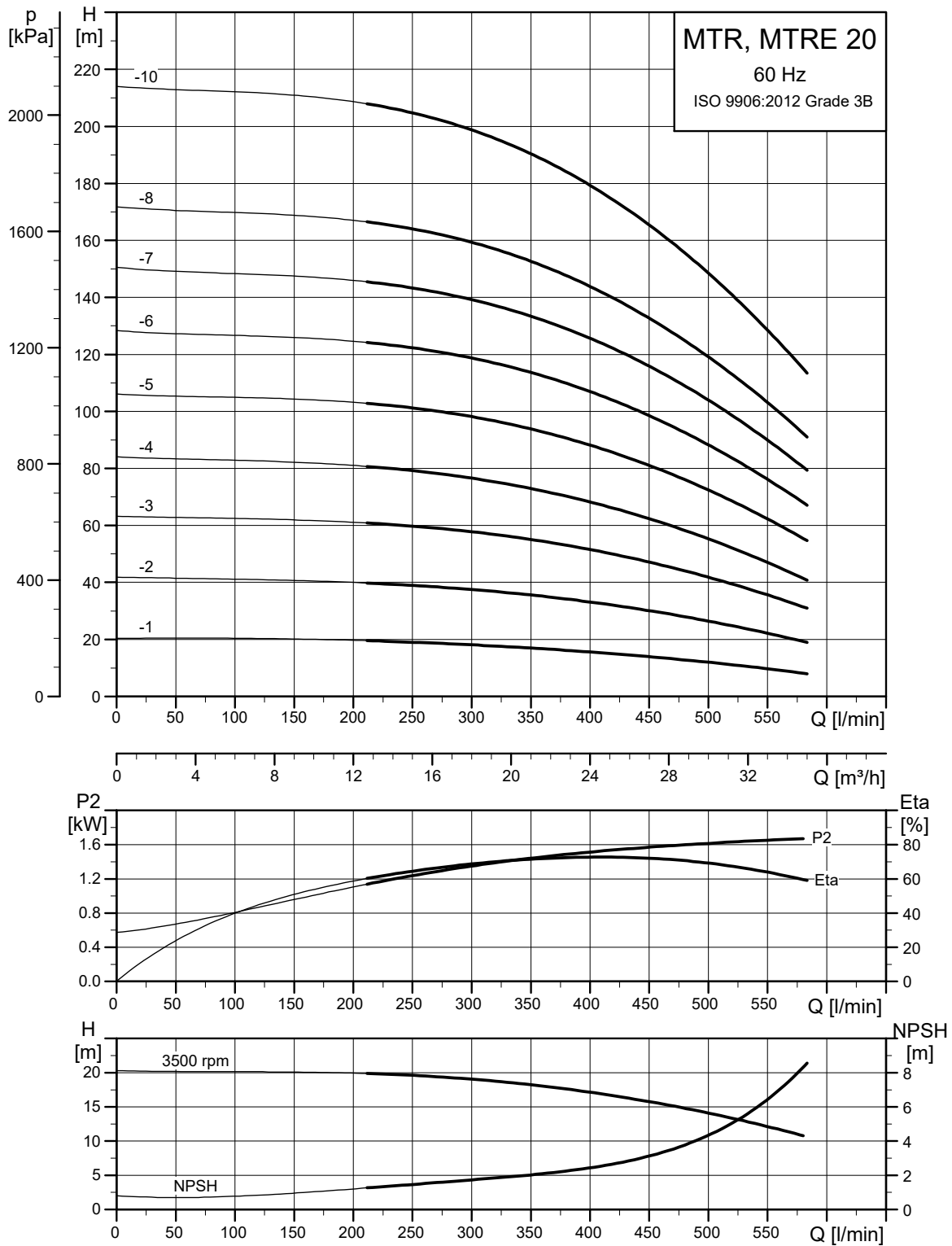

TM027852

Dimensional sketches

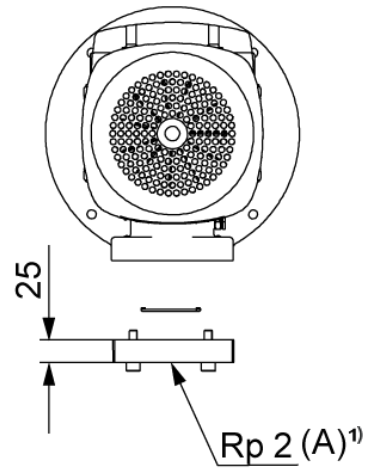
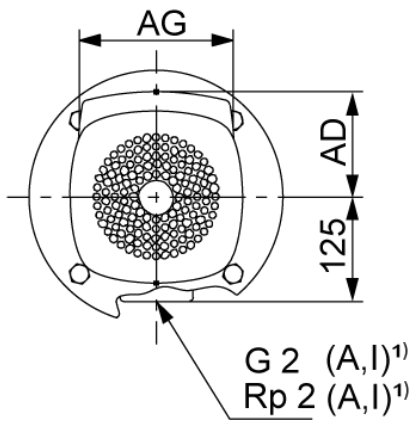
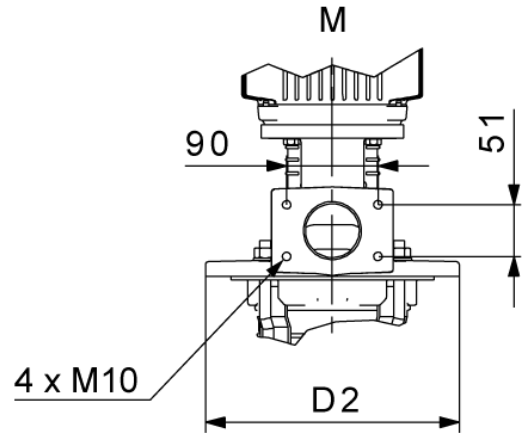
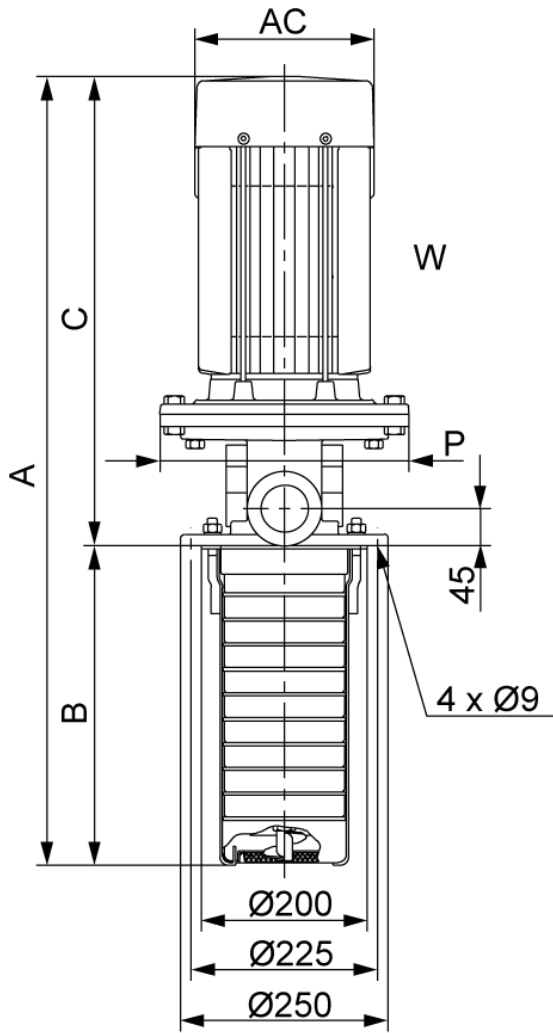

W: Internal thread connection. M: Square flange.

1) A: Basic version, cast iron. I: Stainless steel version.

TM042790

Dimensions and weights

Pump type	P2 [kW]	MTR									MTRE								
		Dimensions [mm]								Net weight [kg]	Dimensions [mm]								Net weight [kg]
		A	B	C	AC	D2	P	AD	AG		A	B	C	AC	D2	P	AD	AG	
MTR, MTRE 20-2/1	2.2	639	178	461	178	140	-	110	162	35.9	592	178	414	122	140	-	158	268	31.6
MTR, MTRE 20-2/2	4	690	178	512	220	160	-	134	202	52.7	652	178	474	191	160	-	201	291	43.9
MTR, MTRE 20-3/3	5.5	778	223	555	220	300	300	134	202	65	752	223	529	191	300	300	201	291	60.3
MTR, MTRE 20-4/4	7.5	811	268	543	260	300	300	159	203	74.9	821	268	553	255	300	300	237	346	69.8
MTR 20-5/5	11	989	313	676	318	350	350	204	243	112.5	-	-	-	-	-	-	-	-	-
MTR, MTRE 20-6/6	11	1034	358	676	318	350	350	204	243	112.6	958	358	600	255	350	350	237	346	89.2
MTR 20-7/7	15	1079	403	676	318	350	350	204	243	124.5	-	-	-	-	-	-	-	-	-
MTR, MTRE 20-8/8	15	1124	448	676	318	350	350	204	243	124.6	1124	448	676	318	350	350	303	420	107.4
MTR, MTRE 20-10/10	18.5	1258	538	720	318	350	350	204	243	137.5	1214	538	676	318	350	350	303	420	112.1
MTR 20-12/10	18.5	1348	628	720	318	350	350	204	243	137.7	-	-	-	-	-	-	-	-	-
MTR 20-14/10	18.5	1438	718	720	318	350	350	204	243	137.9	-	-	-	-	-	-	-	-	-
MTR 20-16/10	18.5	1528	808	720	318	350	350	204	243	138.1	-	-	-	-	-	-	-	-	-
MTR 20-17/10	18.5	1573	853	720	318	350	350	204	243	138.2	-	-	-	-	-	-	-	-	-

The maximum immersion depth is 1033 mm.

MTR, MTRE 32, 60 Hz

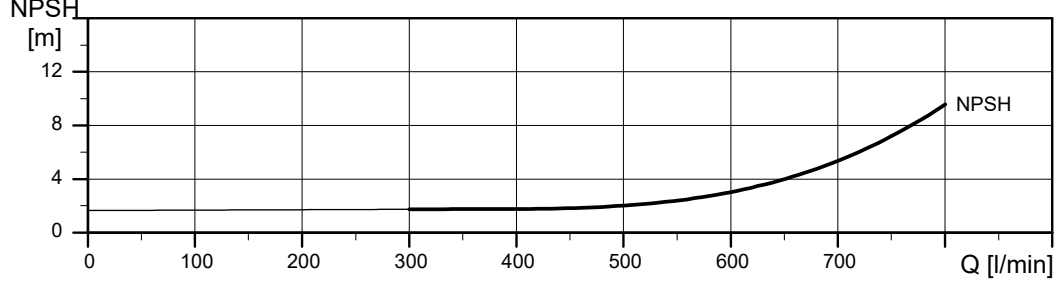
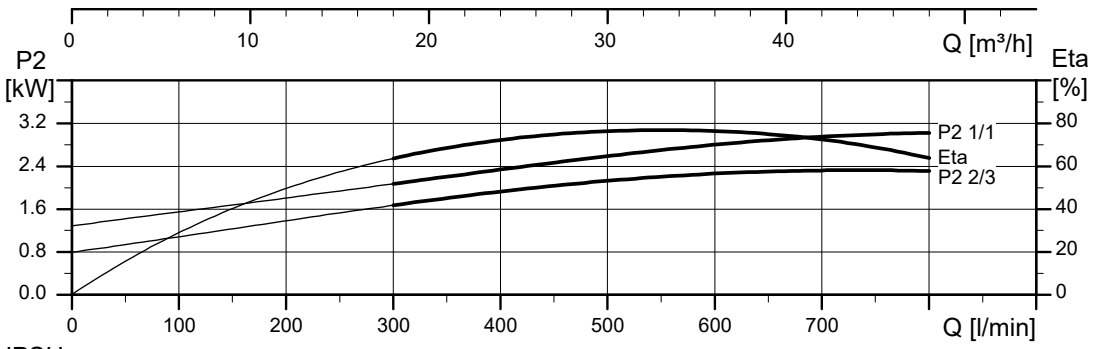
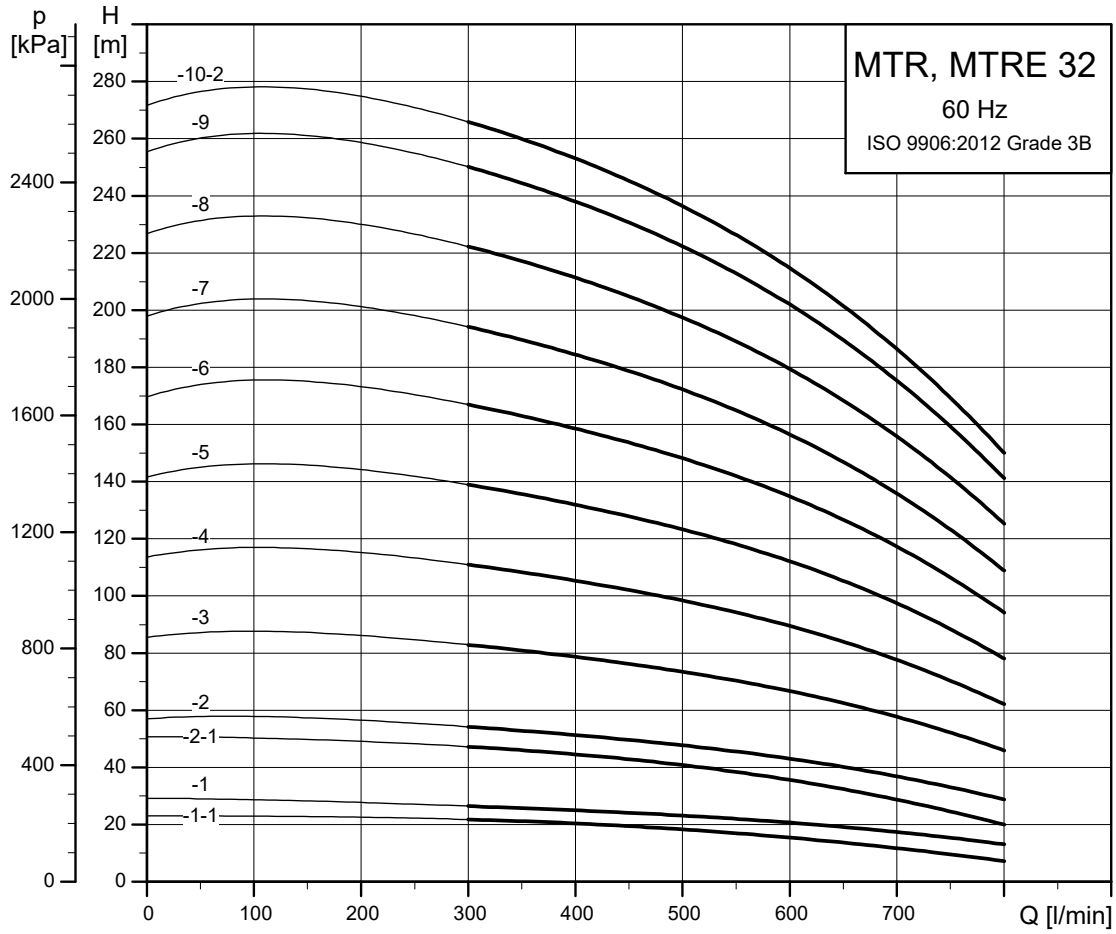

TM014305

Dimensional sketches

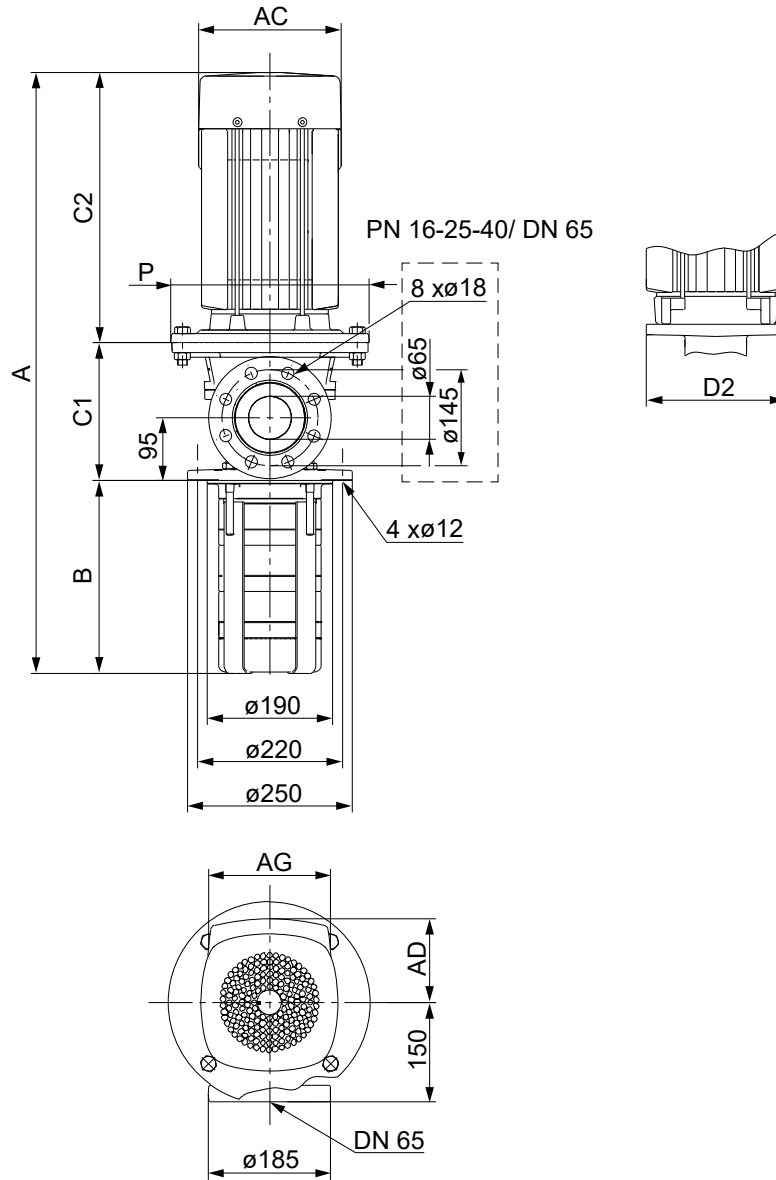

Note that A and C1 are higher for drainage back to tank versions.

Dimensions and weights

Pump type	P2 [kW]	MTR										MTRE											
		Dimensions [mm]										Net weight [kg]	Dimensions [mm]										Net weight [kg]
		A ¹⁴⁾	B	C1 ¹⁴⁾	C2	AC	D2	P	AD	AG	A ¹⁴⁾		B	C1 ¹⁴⁾	C2	AC	D2	P	AD	AG			
MTR, MTRE 32-2/1-1	2.2	682	223	138	321	178	198	-	110	162	57.1	635	223	138	274	12	198	-	158	268	52.8		
MTR, MTRE 32-2/1	3	696	223	138	335	198	198	-	120	162	61.3	695	223	138	334	191	198	-	201	291	61.1		
MTR, MTRE 32-2/2-1	5.5	823	223	209	391	220	298	300	134	202	87.7	797	223	209	365	191	298	300	201	291	82.9		
MTR, MTRE 32-2/2	7.5	811	223	209	379	260	298	300	159	203	97.5	821	223	209	389	255	298	300	237	346	92.3		
MTR, MTRE 32-3/3	11	984	293	209	482	318	350	350	204	243	134.7	908	293	209	406	255	350	350	237	346	111.3		
MTR, MTRE 32-4/4	15	1054	363	209	482	318	350	350	204	243	146.8	1054	363	209	482	318	350	350	303	420	129.6		
MTR 32-5/5	18.5	1168	433	209	526	318	350	350	204	243	159.7	-	-	-	-	-	-	-	-	-	-		
MTR, MTRE 32-6/6	18.5	1238	503	209	526	318	350	350	204	243	160	1194	503	209	482	318	350	350	303	420	134.6		
MTR, MTRE 32-7/7	22	1334	573	209	552	318	350	350	204	243	175.5	1290	573	209	508	318	350	350	303	420	148.8		
MTRE 32-8/8	26	-	-	-	-	-	-	-	-	-	-	1290	573	209	508	318	350	350	303	420	150.4		
MTR 32-8/8	30	1463	643	209	611	396	400	400	315	265	275.5	-	-	-	-	-	-	-	-	-	-		

TM042791

Pump type	P2 [kW]	MTR										MTRE																			
		Dimensions [mm]										Net weight [kg]	Dimensions [mm]										Net weight [kg]								
		A ¹⁴⁾	B	C1 ¹⁴⁾	C2	AC	D2	P	AD	AG	A ¹⁴⁾		B	C1 ¹⁴⁾	C2	AC	D2	P	AD	AG											
MTR 32-9/9	30	1533	713	209	611	396	400	400	315	265	275.8	-	-	-	-	-	-	-	-	-	-	-	-	-	-	-	-	-	-	-	-
MTR 32-10/10-2	30	1603	783	209	611	396	400	400	315	265	276	-	-	-	-	-	-	-	-	-	-	-	-	-	-	-	-	-	-	-	-
MTR 32-11/10-2	30	1673	853	209	611	396	400	400	315	265	276.3	-	-	-	-	-	-	-	-	-	-	-	-	-	-	-	-	-	-	-	-
MTR 32-12/10-2	30	1743	923	209	611	396	400	400	315	265	276.6	-	-	-	-	-	-	-	-	-	-	-	-	-	-	-	-	-	-	-	-
MTR 32-13/10-2	30	1813	993	209	611	396	400	400	315	265	276.8	-	-	-	-	-	-	-	-	-	-	-	-	-	-	-	-	-	-	-	-
MTR 32-14/10-2	30	1883	1063	209	611	396	400	400	315	265	277.1	-	-	-	-	-	-	-	-	-	-	-	-	-	-	-	-	-	-	-	-

¹⁴⁾+20 mm for MTR, MTRE pumps with drainage back to the tank.

The maximum immersion depth is 1343 mm.

MTR, MTRE 45, 60 Hz

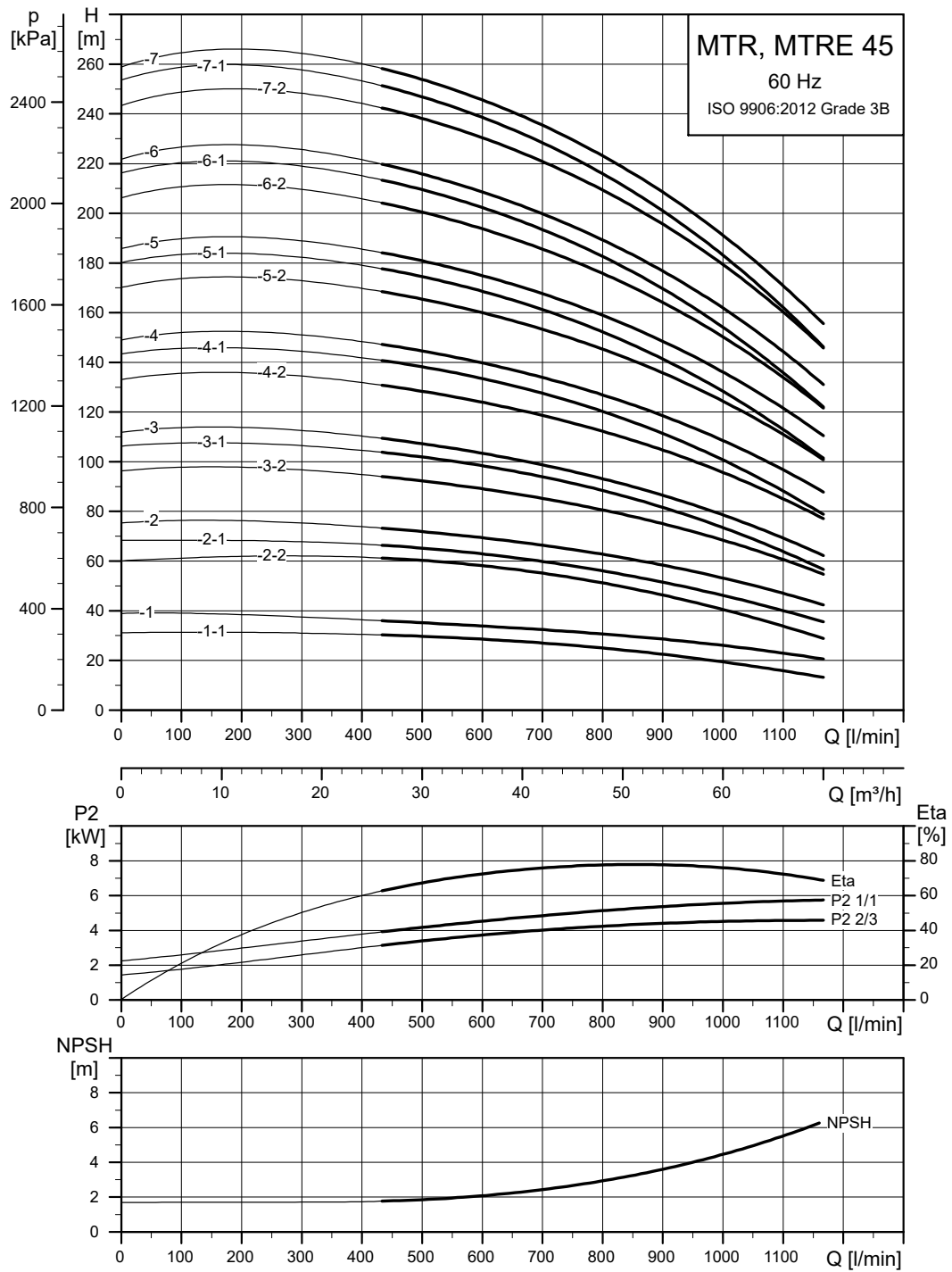

TM014306

Dimensional sketches

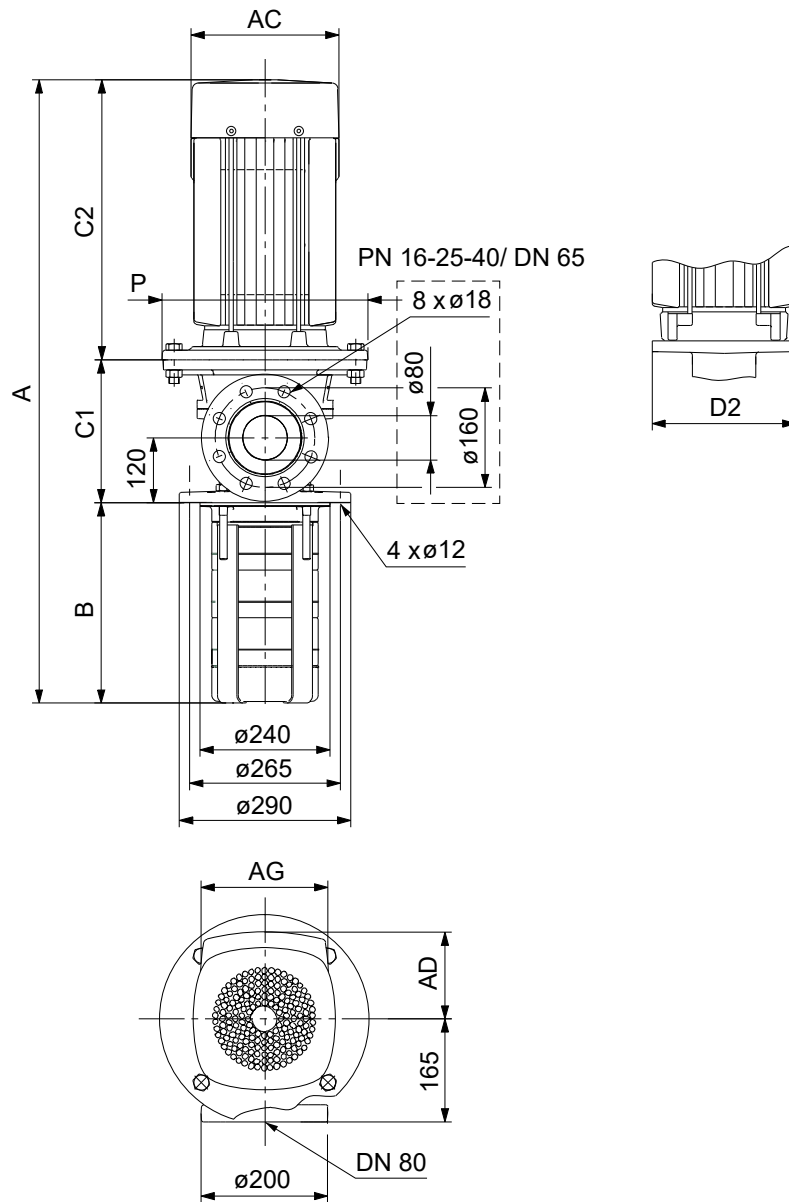

TM042792

Dimensions and weights

Pump type	P2 [kW]	MTR										MTRE									
		Dimensions [mm]										Net weight [kg]	Dimensions [mm]								Net weight [kg]
		A ¹⁵⁾	B	C1 ¹⁵⁾	C2	AC	D2	P	AD	AG	A ¹⁵⁾		B	C1 ¹⁵⁾	C2	AC	D2	P	AD	AG	
MTR, MTRE 45-2/1-1	5.5	875	244	240	391	220	298	300	134	202	96.3	849	244	240	365	191	298	300	201	291	91.6
MTR, MTRE 45-2/1	7.5	863	244	240	379	260	298	300	159	203	106.1	873	244	240	389	255	298	300	237	346	101
MTR, MTRE 45-2/2-2	11	966	244	240	482	318	350	350	204	243	144.1	-	-	-	-	-	-	-	-	-	-
MTR, MTRE 45-2/2-1	11	966	244	240	482	318	350	350	204	243	144.1	890	244	240	406	255	350	350	237	346	120.8
MTR, MTRE 45-2/2	15	966	244	240	482	318	350	350	204	243	155.9	966	244	240	482	318	350	350	303	420	138.7
MTR 45-3/3-2	18.5	1090	324	240	526	318	350	350	204	243	168.9	-	-	-	-	-	-	-	-	-	-
MTR 45-3/3-1	18.5	1090	324	240	526	318	350	350	204	243	168.9	-	-	-	-	-	-	-	-	-	-
MTR, MTRE 45-3/3	18.5	1090	324	240	526	318	350	350	204	243	168.9	1046	324	240	482	318	350	350	303	420	143.5
MTR, MTRE 45-4/4-2	22	1196	404	240	552	318	350	350	204	243	184.4	1152	404	240	508	318	350	350	303	420	157.8
MTRE 45-4/4	26	-	-	-	-	-	-	-	-	-	-	1152	404	240	508	318	350	350	303	420	158.0
MTR 45-4/4-1	30	1255	404	240	611	396	400	400	315	265	284.2	-	-	-	-	-	-	-	-	-	-
MTR 45-4/4	30	1255	404	240	611	396	400	400	315	265	284.2	-	-	-	-	-	-	-	-	-	-

MTR, MTRE 64, 60 Hz

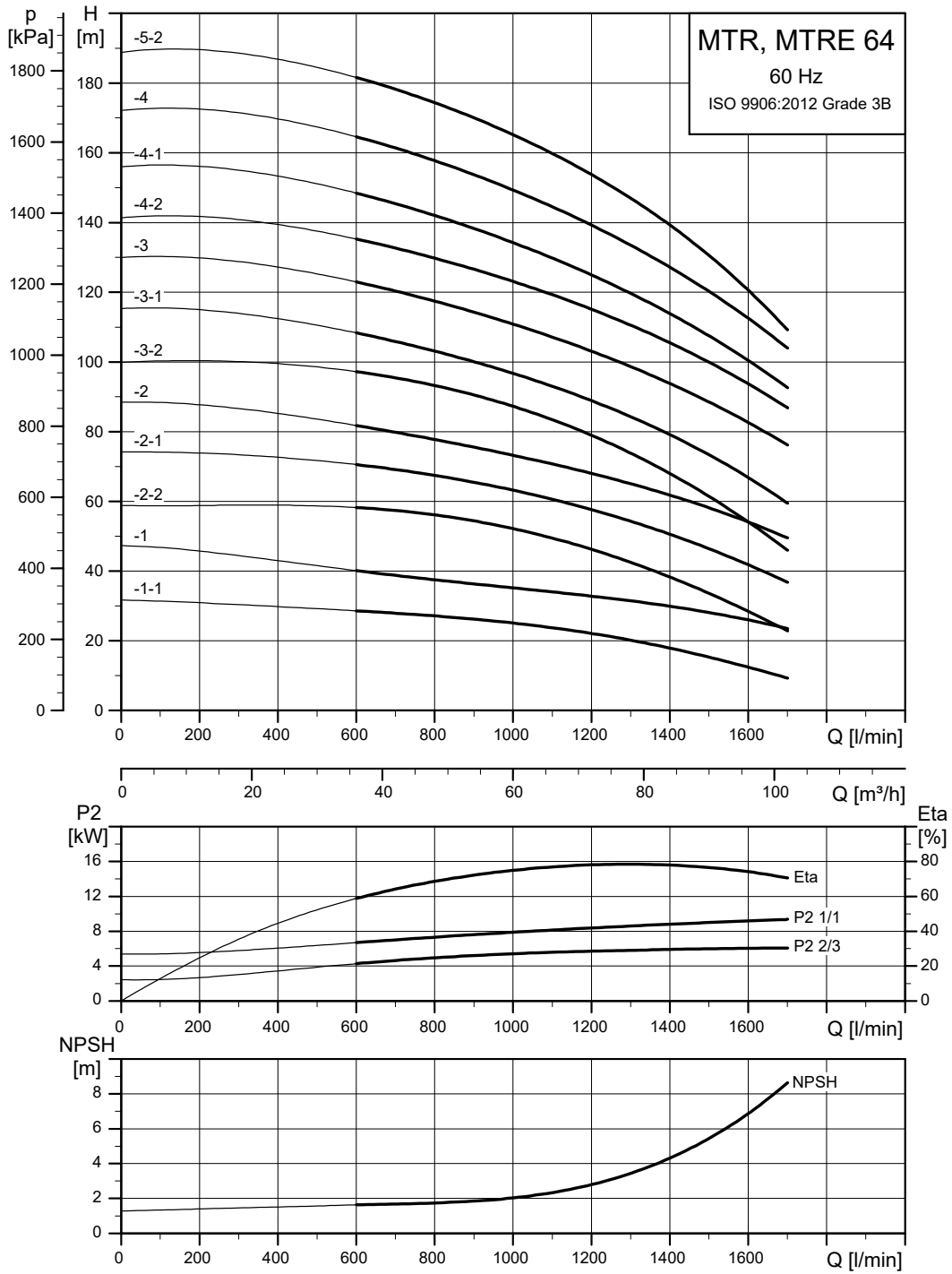

TM014307

Dimensional sketches

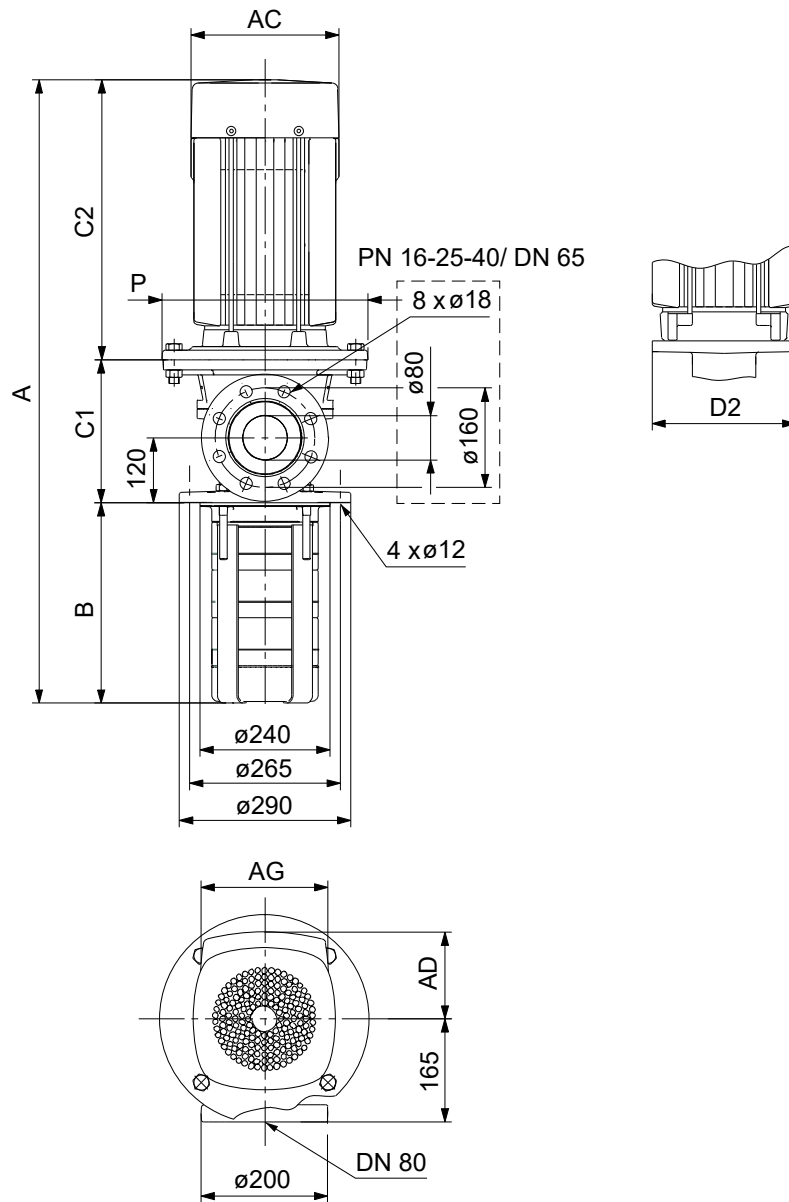

TM042792

Dimensions and weights

Pump type	P2 [kW]	MTR										MTRE									
		Dimensions [mm]										Net weight [kg]	Dimensions [mm]								Net weight [kg]
		A ¹⁶⁾	B	C1 ¹⁶⁾	C2	AC	D2	P	AD	AG	A ¹⁶⁾		B	C1 ¹⁶⁾	C2	AC	D2	P	AD	AG	
MTR, MTRE 64-2/1-1	7.5	868	249	240	379	260	298	300	159	203	109.2	878	249	240	389	255	298	300	237	346	104
MTR, MTRE 64-2/1	11	971	249	240	482	318	350	350	204	243	147.2	895	249	240	406	255	350	350	237	346	123.8
MTR, MTRE 64-2/2-2	15	971	249	240	482	318	350	350	204	243	159	971	249	240	482	318	350	350	303	420	141.8
MTR, MTRE 64-2/2-1	18.5	1015	249	240	526	318	350	350	204	243	171.7	971	249	240	482	318	350	350	303	420	146.3
MTR, MTRE 64-2/2	22	1041	249	240	552	318	350	350	204	243	186.9	997	249	240	508	318	350	350	303	420	160.2
MTR, MTRE 64-3/3-2	22	1124	332	240	552	318	350	350	204	243	187.2	1080	332	240	508	318	350	350	303	420	160.5
MTRE 64-3/3-1	26	-	-	-	-	-	-	-	-	-	-	1080	332	240	508	318	350	350	303	420	160.6
MTR 64-3/3-1	30	1183	332	240	611	396	400	400	315	265	287	-	-	-	-	-	-	-	-	-	-
MTR 64-3/3	30	1183	332	240	611	396	400	400	315	265	287	-	-	-	-	-	-	-	-	-	-
MTR 64-4/4-2	37	1290	414	240	636	396	400	400	315	265	312.3	-	-	-	-	-	-	-	-	-	-
MTR 64-4/4-1	37	1290	414	240	636	396	400	400	315	265	312.3	-	-	-	-	-	-	-	-	-	-
MTR 64-4/4	45	1381	414	259	708	449	450	450	338	266	414.7	-	-	-	-	-	-	-	-	-	-

MTRE for high-pressure applications

For high-pressure applications, Grundfos offers a unique MTR pump capable of generating up to 38 bar. These pumps are equipped with a high-speed motor, type MGE.

MTRE 1s high-pressure pump

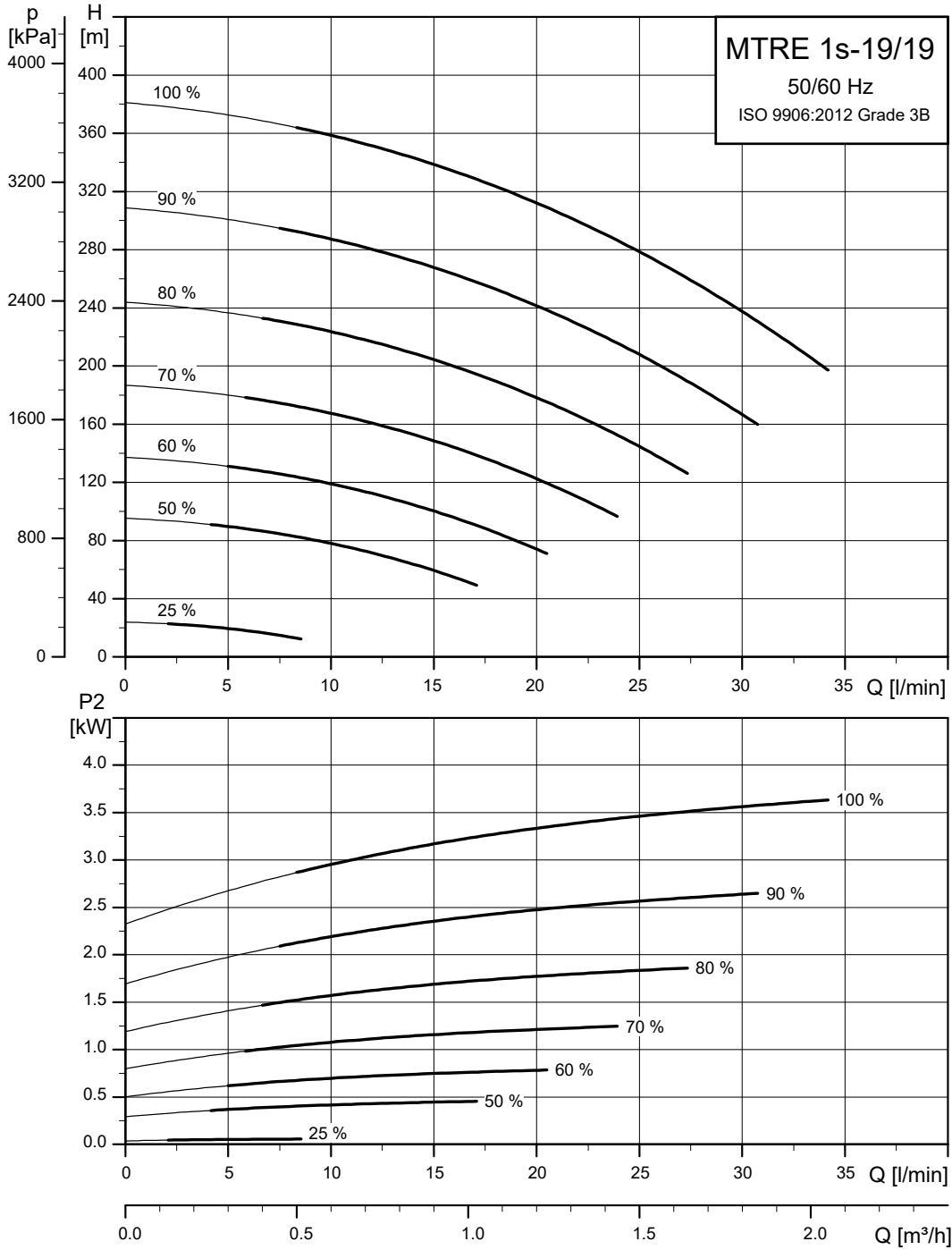

TM051563

Dimensional sketches

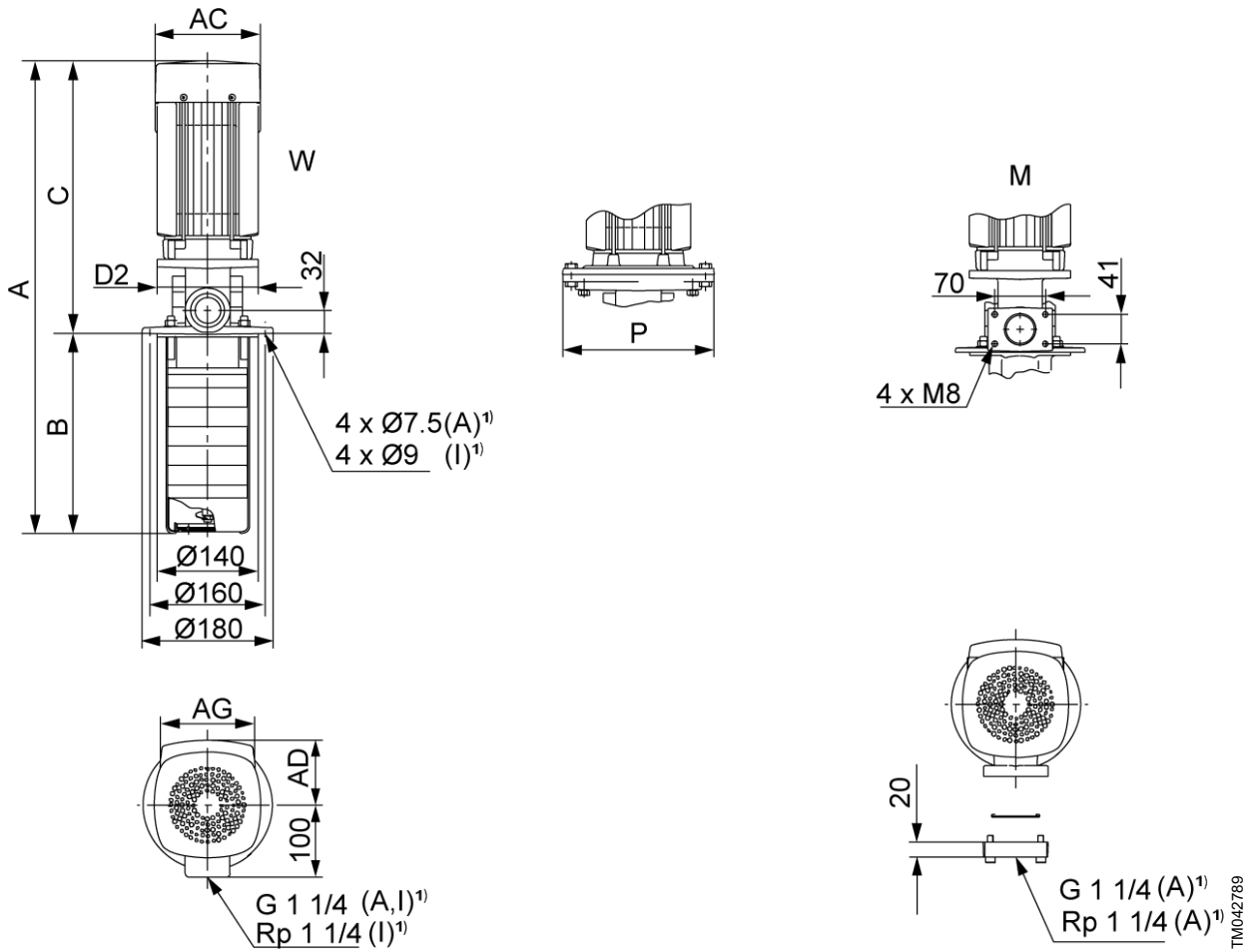

W: Internal thread connection. M: Square flange.

1) A: Basic version, cast iron. I: Stainless steel version.

Dimensions and weight

Pump type	P2 [kW]	Dimensions [mm]								Weight [kg]
		A	B	C	AC	D2	P	AD	AG	
MTRE1s-19/19 HS	4	968	466	502	191	140		201	291	51.2

The maximum immersion depth is 1006 mm.

Electrical data

Voltage	P2 [kW]	Type	I _{1/1} [A]	Power factor cos φ _{1/1}	Motor efficiency		Max. motor speed [min ⁻¹]
					η [%]	Class	
3 x 380-500 V, 50/60 Hz	4	MGE112MC	7.60 - 6.10	0.87 - 0.92	91.3	IE5	5900

MTRE 1 high-pressure pump

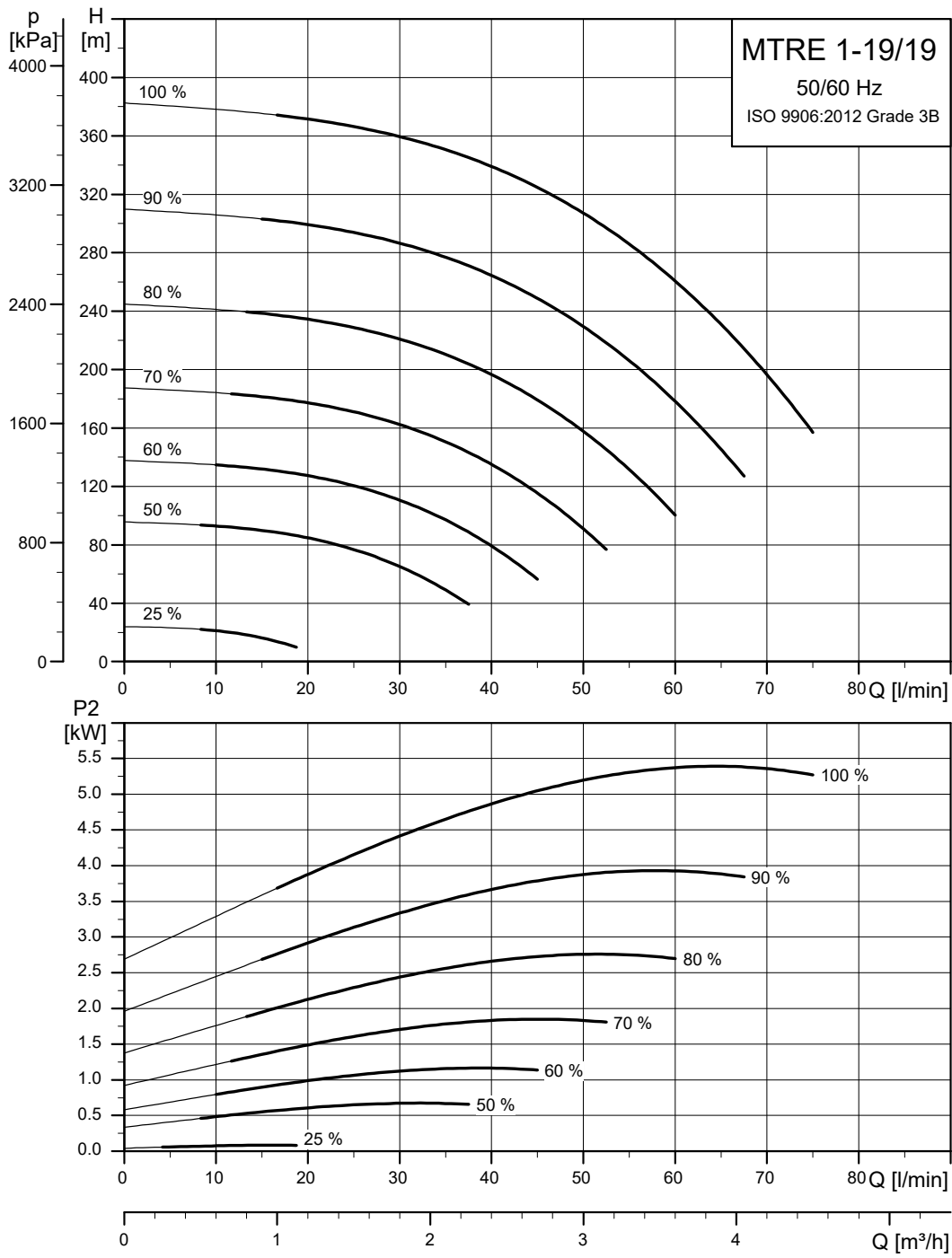

TM045677

Dimensional sketches

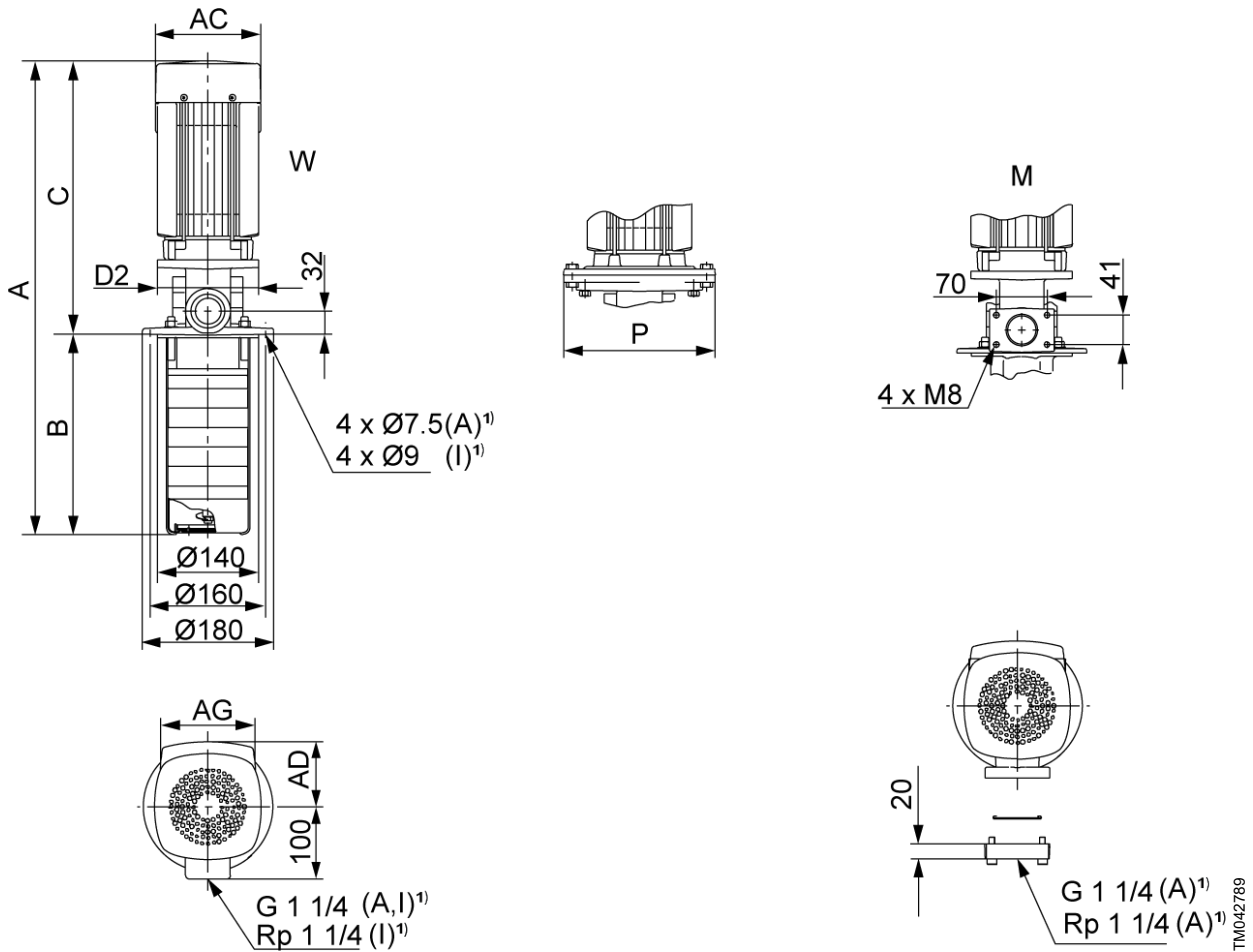

W: Internal thread connection. M: Square flange.

1) A: Basic version, cast iron. I: Stainless steel version.

Dimensions and weight

Pump type	Dimensions [mm]								Weight [kg]
	A	B	C	AC	D2	P	AD	AG	
MTRE1-19/19 HS	1019	466	553	191	160	300	201	291	68.3

The maximum immersion depth is 1006 mm.

Electrical data

Voltage	P2 [kW]	Type	I _{1/1} [A]	Power factor cos φ _{1/1}	Motor efficiency		Max. motor speed [min ⁻¹]
					η [%]	Class	
3 x 380-500 V, 50/60 Hz	5.5	MGE132SE	10.5 - 8.30	0.92 - 0.88	90.5	IE5	5900

MTRE 3 high-pressure pump

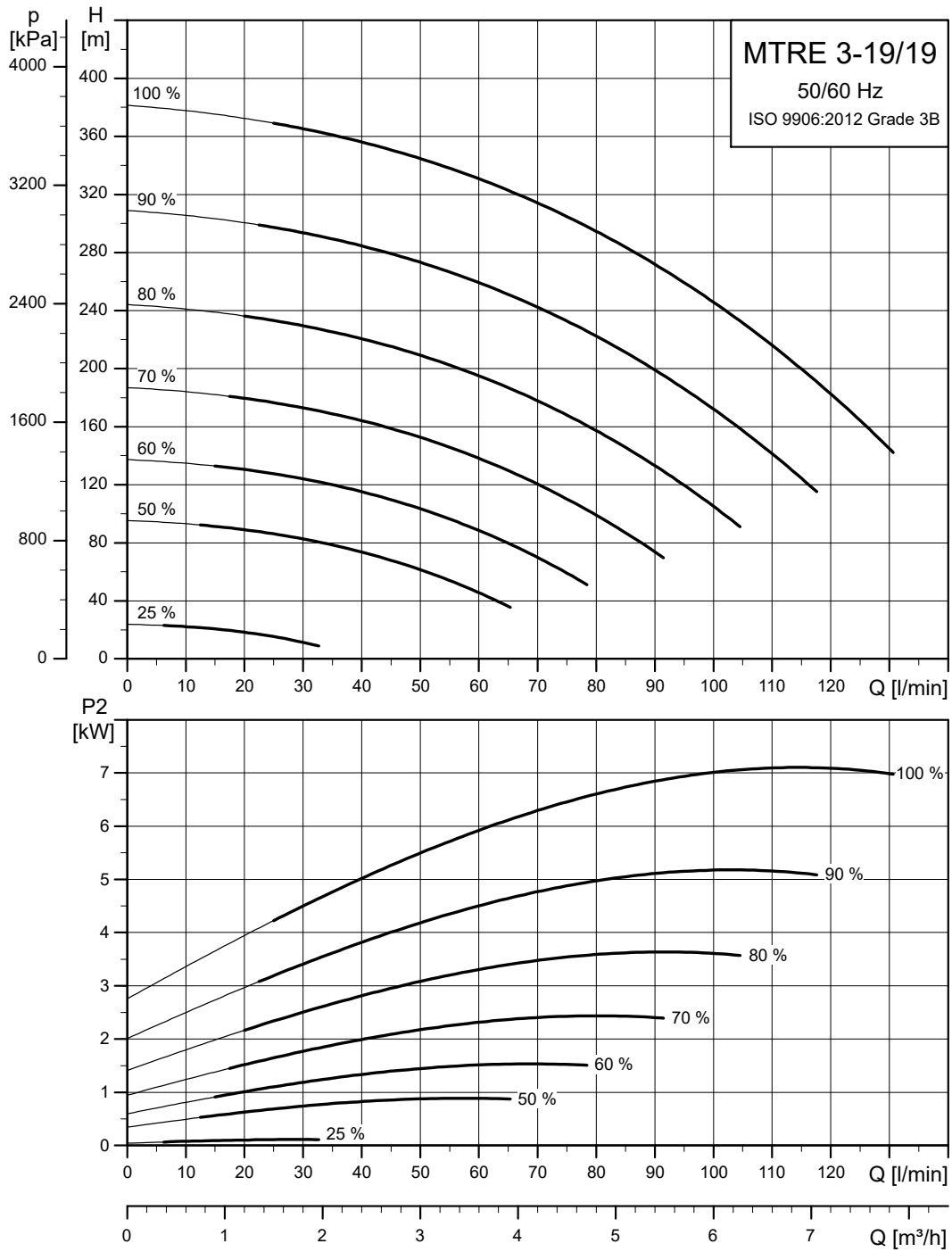

TM051564

Dimensional sketches

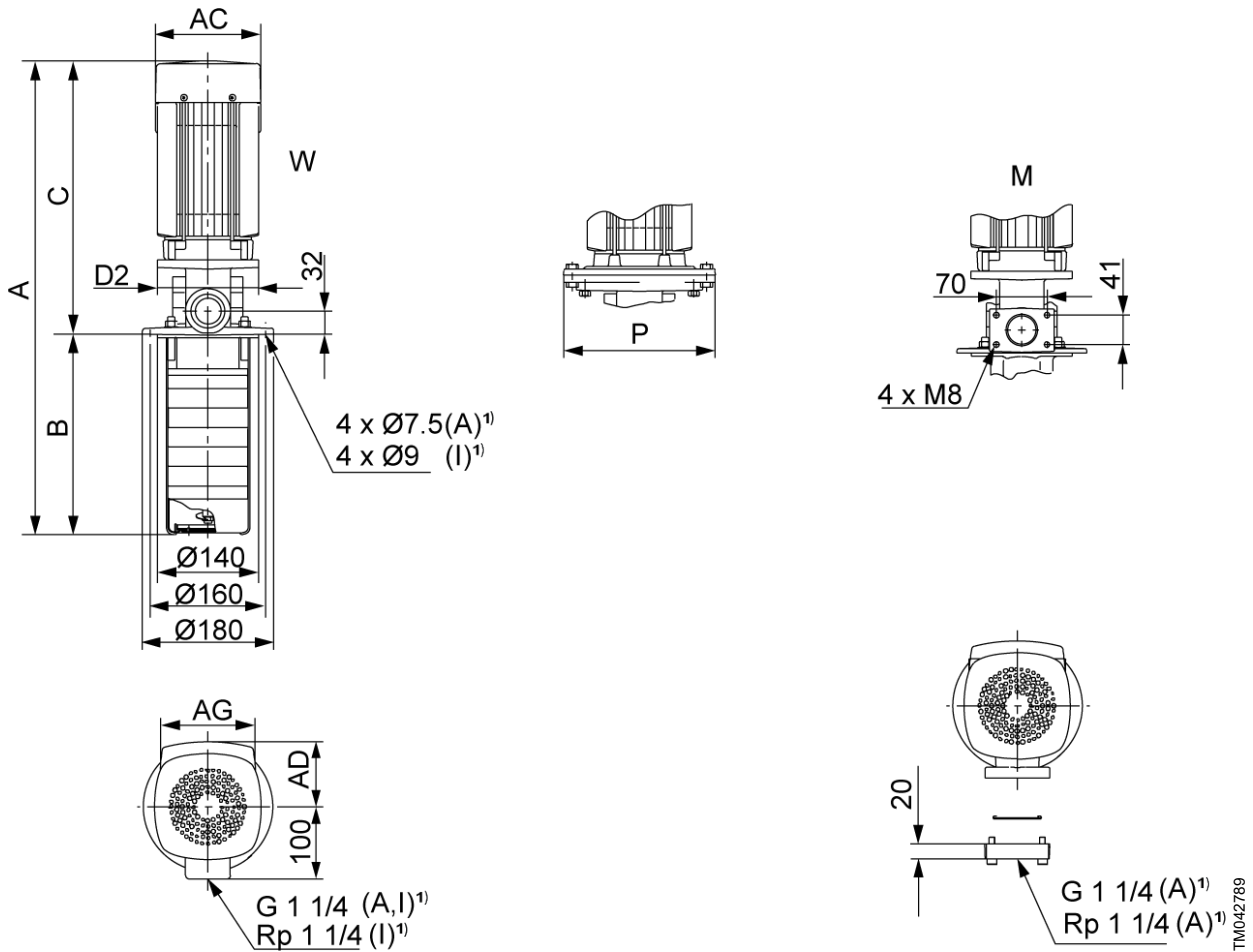

W: Internal thread connection. M: Square flange.

1) A: Basic version, cast iron. I: Stainless steel version.

Dimensions and weight

Pump type	Dimensions [mm]								Weight [kg]
	A	B	C	AC	D2	P	AD	AG	
MTRE3-19/19 HS	1037	466	571	255	160	300	237	346	73.9

The maximum immersion depth is 1006 mm.

Electrical data

Voltage	P2 [kW]	Type	I _{1/1} [A]	Power factor cos φ _{1/1}	Motor efficiency		Max. motor speed [min ⁻¹]
					η [%]	Class	
3 x 380-500 V, 50/60 Hz	7.5	MGE132SF	14.2 - 11.3	0.93 - 0.89	90.9	IE5	5900

SPK, 50 Hz

SPK 1, 50 Hz

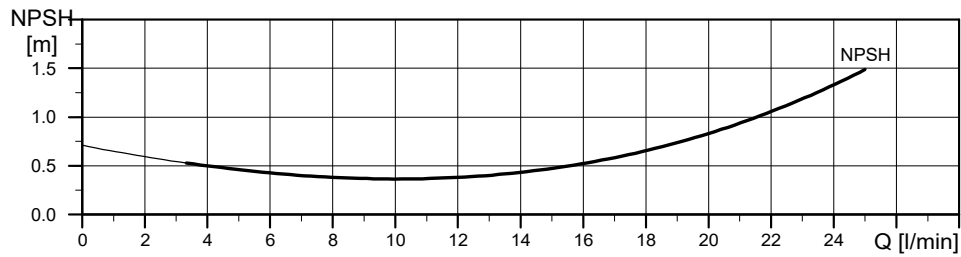
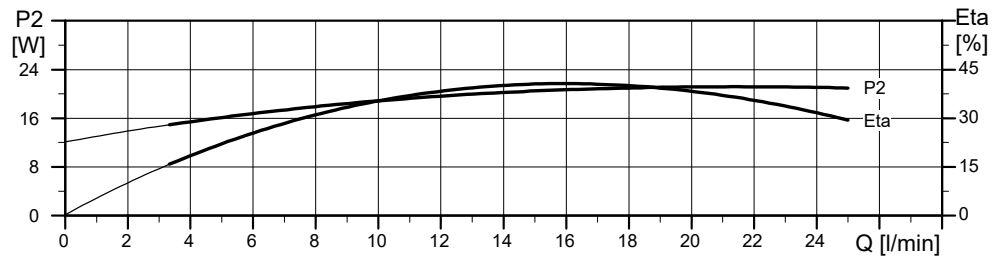
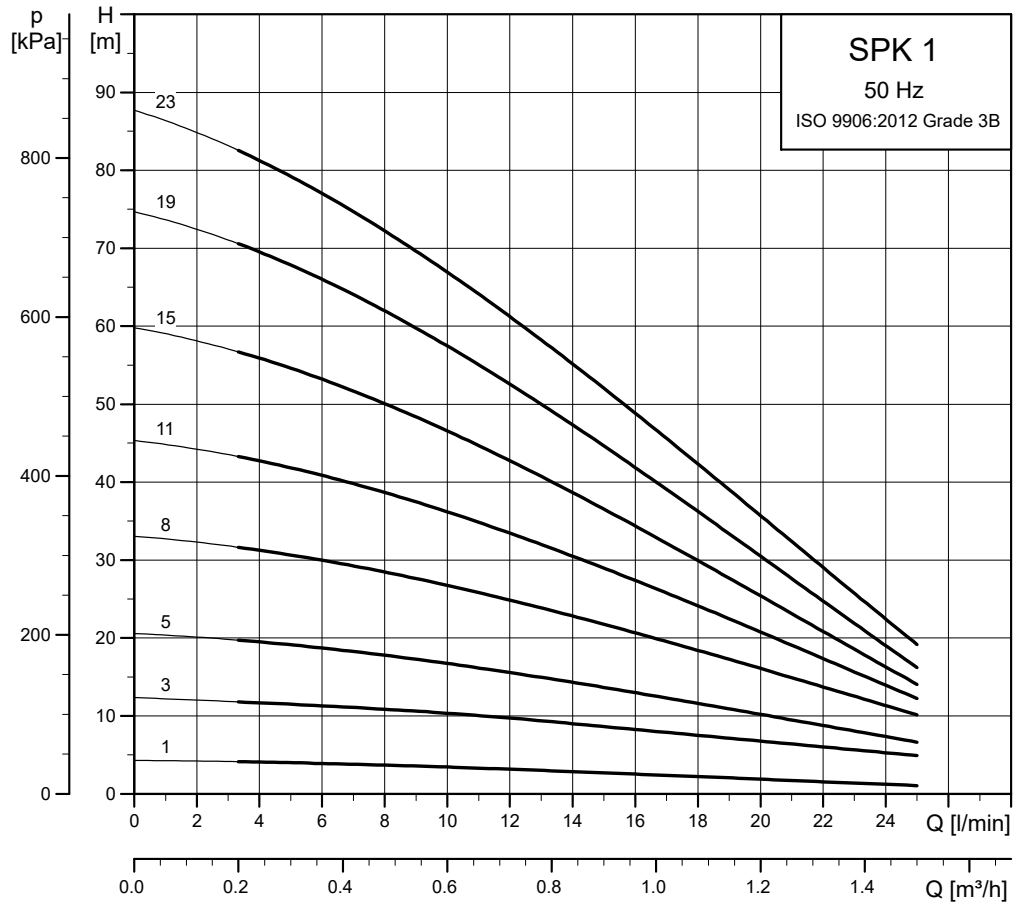

TM001930

Dimensional sketches

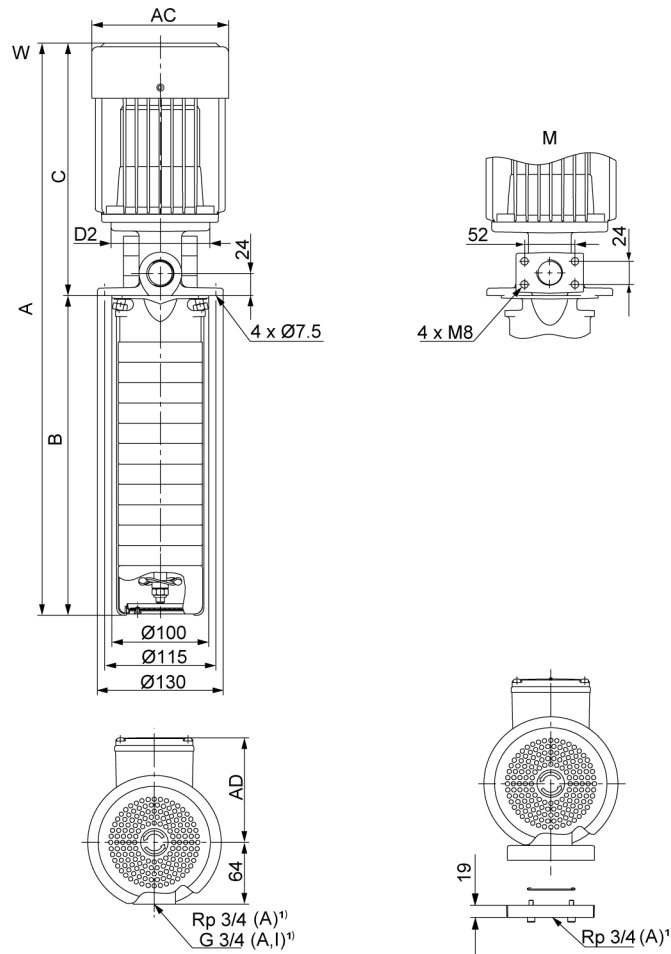

TMD45801

W: Internal thread connection. M: Square flange.

1) A: Basic version, cast iron. I: Stainless steel version.

Dimensions and weights

Pump type	P2 [kW]	Dimensions [mm]						Weight ¹⁷⁾ [kg]
		A	B	C	AC	D2	AD	
SPK 1-1/1	0.06	395	140	255	124	90	101	9.3
SPK 1-3/3	0.12	437	182	255	124	90	101	8.7
SPK 1-5/5	0.12	479	224	255	124	90	101	9.3
SPK 1-8/8	0.18	543	287	256	124	90	101	10.1
SPK 1-11/11	0.25	596	350	246	141	102	109	12.6
SPK 1-15/15	0.37	701	434	267	141	102	109	14
SPK 1-19/19	0.37	785	518	267	141	102	109	15.1
SPK 1-23/23	0.55	869	602	267	141	102	109	15.7

SPK with extension pipe

Pump type	P2 [kW]	Dimensions [mm]						Weight ¹⁷⁾ [kg]
		A	B	C	AC	D2	AD	
SPK 1-23/23	0.55	1272	1005	267	141	102	109	20.3

¹⁷⁾The weights apply to the standard range (A-version). For the stainless steel versions (I-version), add 1 kg.

For information about electrical data, see the section on electrical data.

SPK 2, 50 Hz

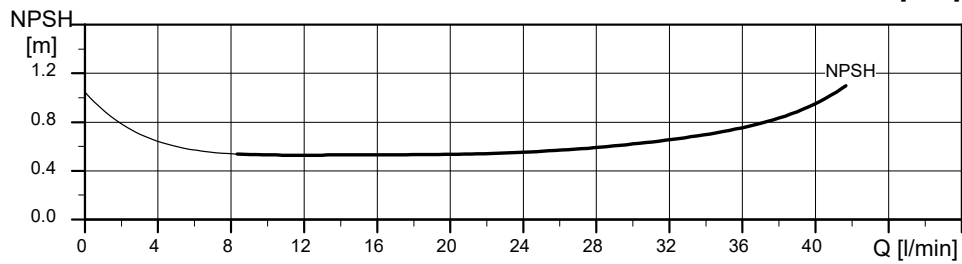
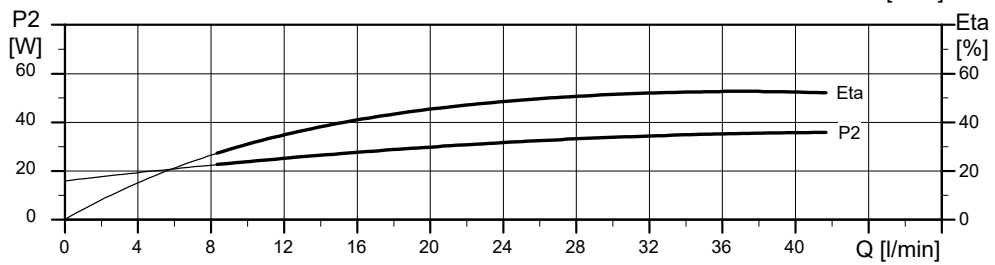
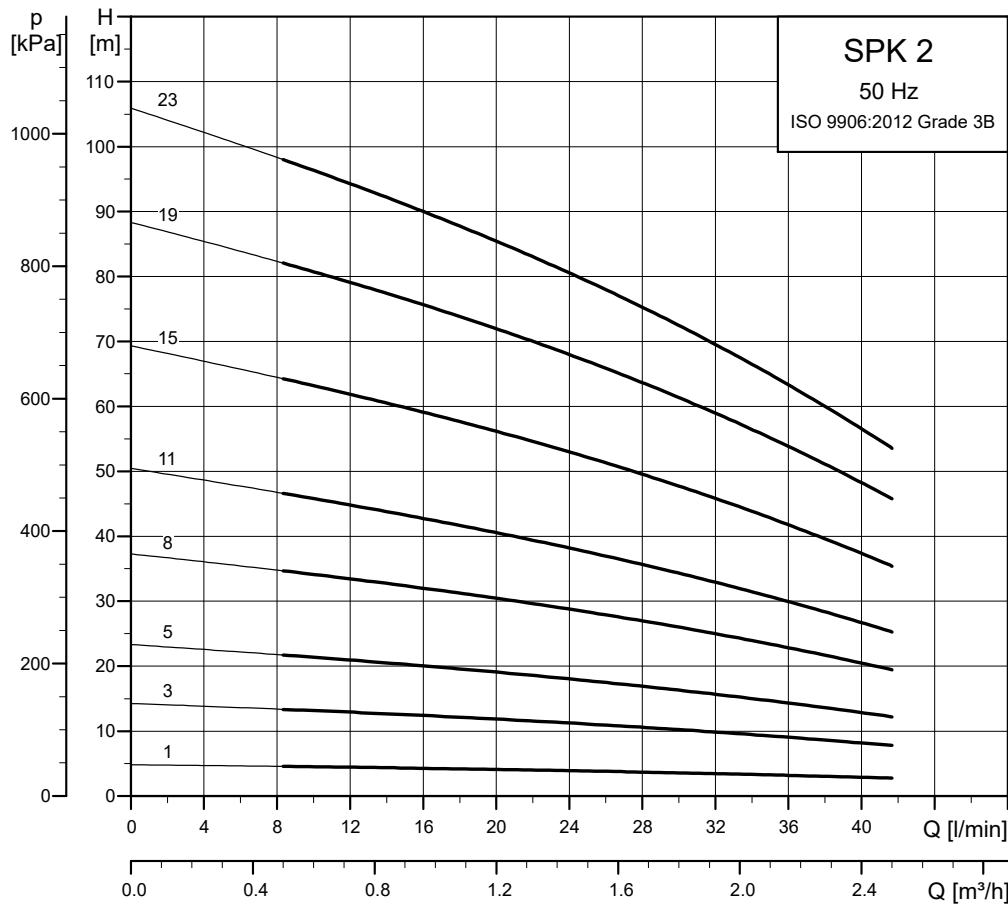

TM001932

Dimensional sketches

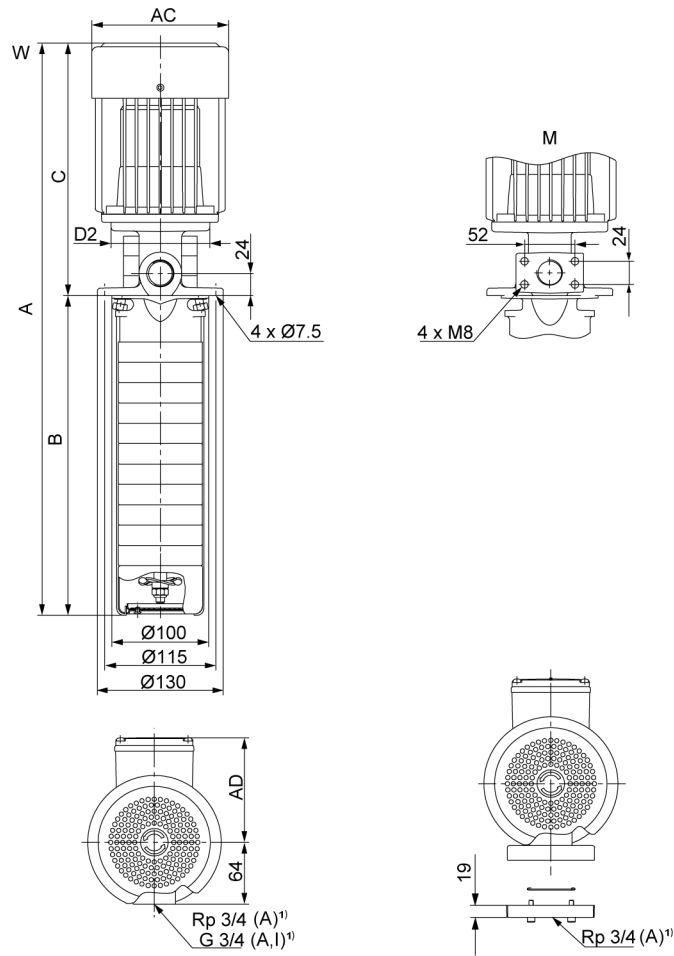

W: Internal thread connection. M: Square flange.

1) A: Basic version, cast iron. I: Stainless steel version.

Dimensions and weights

Pump type	P2 [kW]	Dimensions [mm]						Weight ¹⁸⁾ [kg]
		A	B	C	AC	D2	AD	
SPK 2-1/1	0.06	395	140	255	124	90	101	9.3
SPK 2-3/3	0.12	437	182	255	124	90	101	8.8
SPK 2-5/5	0.18	480	224	256	124	90	101	9.3
SPK 2-8/8	0.37	554	287	267	141	102	109	12.1
SPK 2-11/11	0.37	617	350	267	141	102	109	12.9
SPK 2-15/15	0.55	701	434	267	141	102	109	13.6
SPK 2-19/19	0.75	825	518	307	141	120	109	17.2
SPK 2-23/23	0.75	909	602	307	141	120	109	18.4

¹⁸⁾ The weights apply to the standard range (A-version). For the stainless steel versions (I-version), add 1 kg.

SPK with extension pipe

Pump type	P2 [kW]	Dimensions [mm]						Weight ¹⁸⁾ [kg]
		A	B	C	AC	D2	AD	
SPK 2-23/23	0.75	1312	1005	307	141	120	109	23

For information about electrical data, see the section on electrical data.

TMD45801

SPK 4, 50 Hz

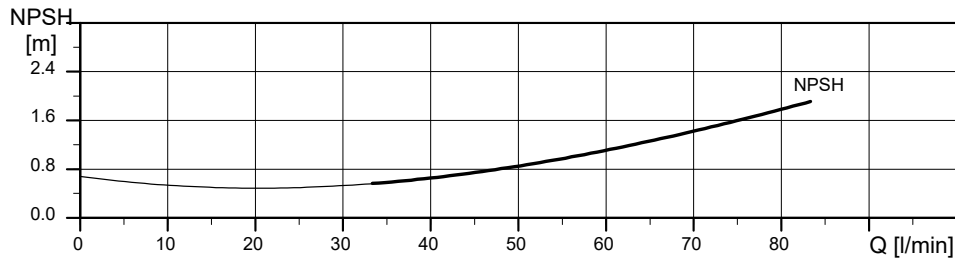
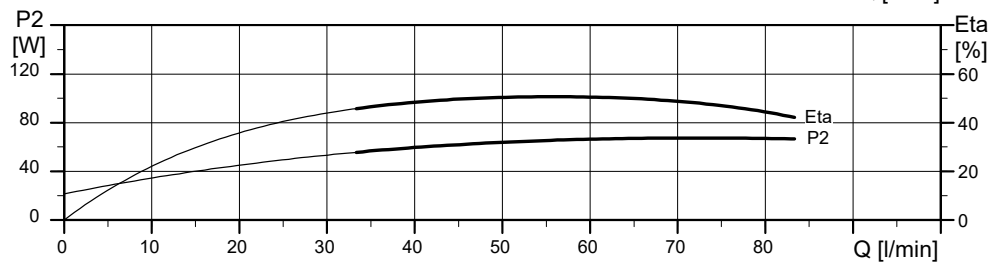
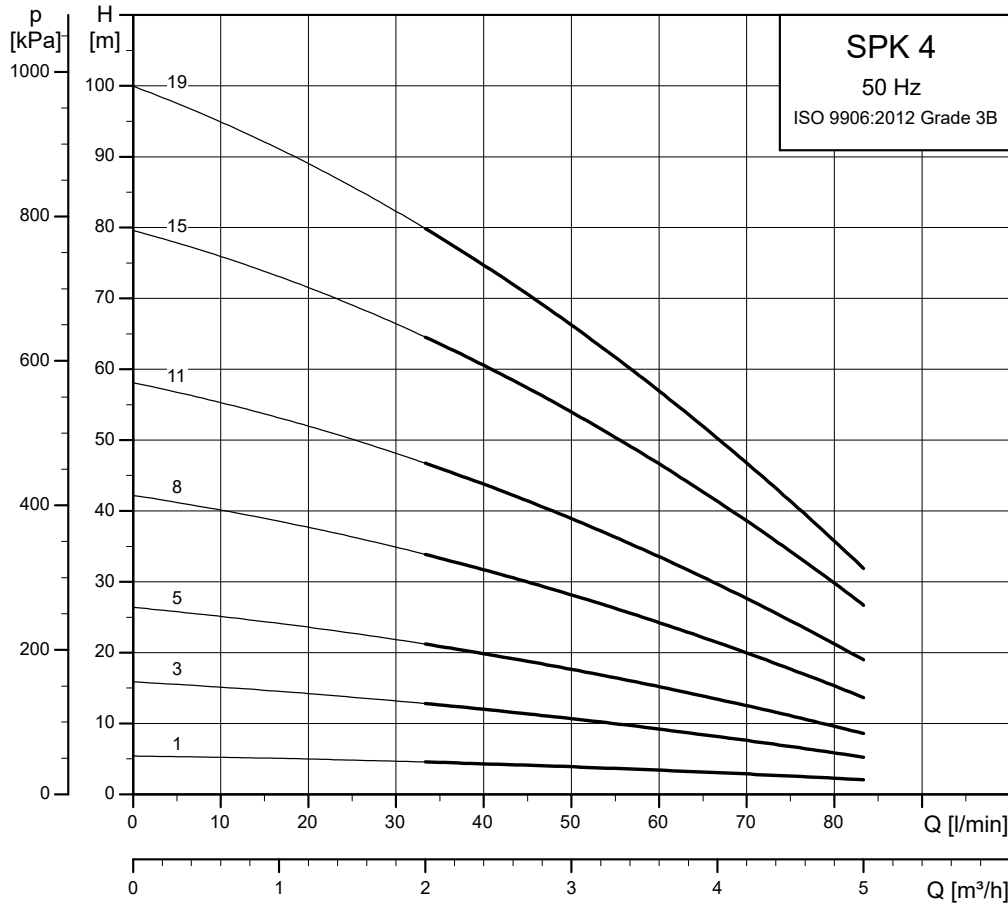

TM001934

Dimensional sketches

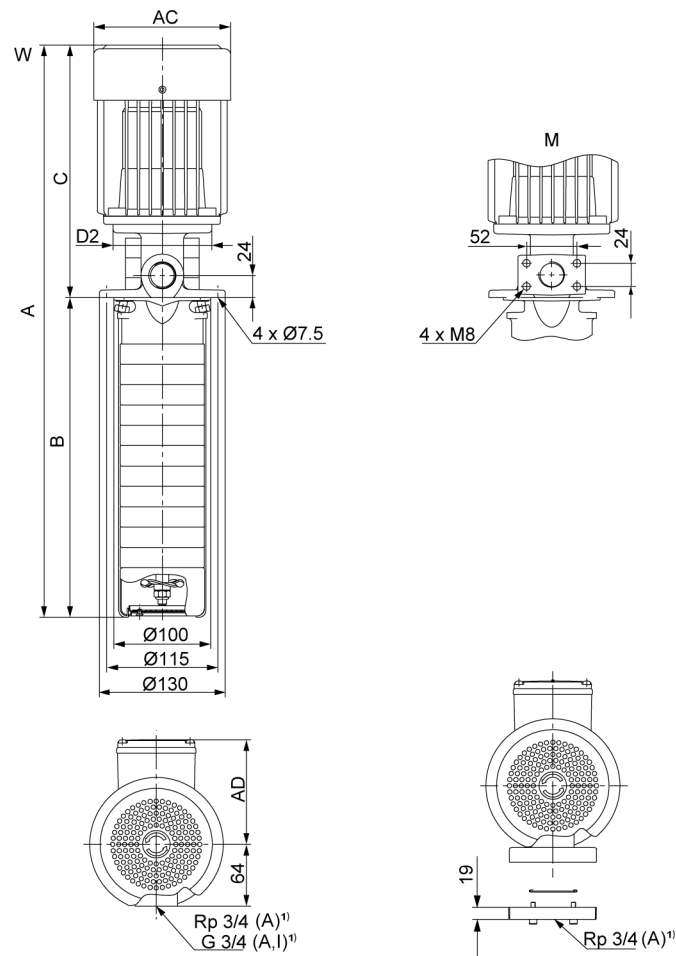

W: Internal thread connection. M: Square flange.

1) A: Basic version, cast iron. I: Stainless steel version.

Dimensions and weights

Pump type	P2 [kW]	Dimensions [mm]						Weight ¹⁹⁾ [kg]
		A	B	C	AC	D2	AD	
SPK 4-1/1	0.12	395	140	255	124	90	101	8.3
SPK 4-3/3	0.25	428	182	246	141	102	109	10.3
SPK 4-5/5	0.37	491	224	267	141	102	109	10.8
SPK 4-8/8	0.55	554	287	267	141	102	109	10.7
SPK 4-11/11	0.75	657	350	307	141	120	109	13.6
SPK 4-15/15	1.1	761	434	327	141	120	109	16.3
SPK 4-19/19	1.1	845	518	327	141	120	109	16.9

¹⁹⁾ The weights apply to the standard range (A-version). For the stainless steel versions (I-version), add 1.3 kg.

SPK with extension pipe

Pump type	P2 [kW]	Dimensions [mm]						Weight ¹⁹⁾ [kg]
		A	B	C	AC	D2	AD	
SPK 4-19/19	1.1	1332	1005	327	141	120	109	22.1

For information about electrical data, see the section on electrical data.

TMD45801

SPK, 60 Hz

SPK 1, 60 Hz

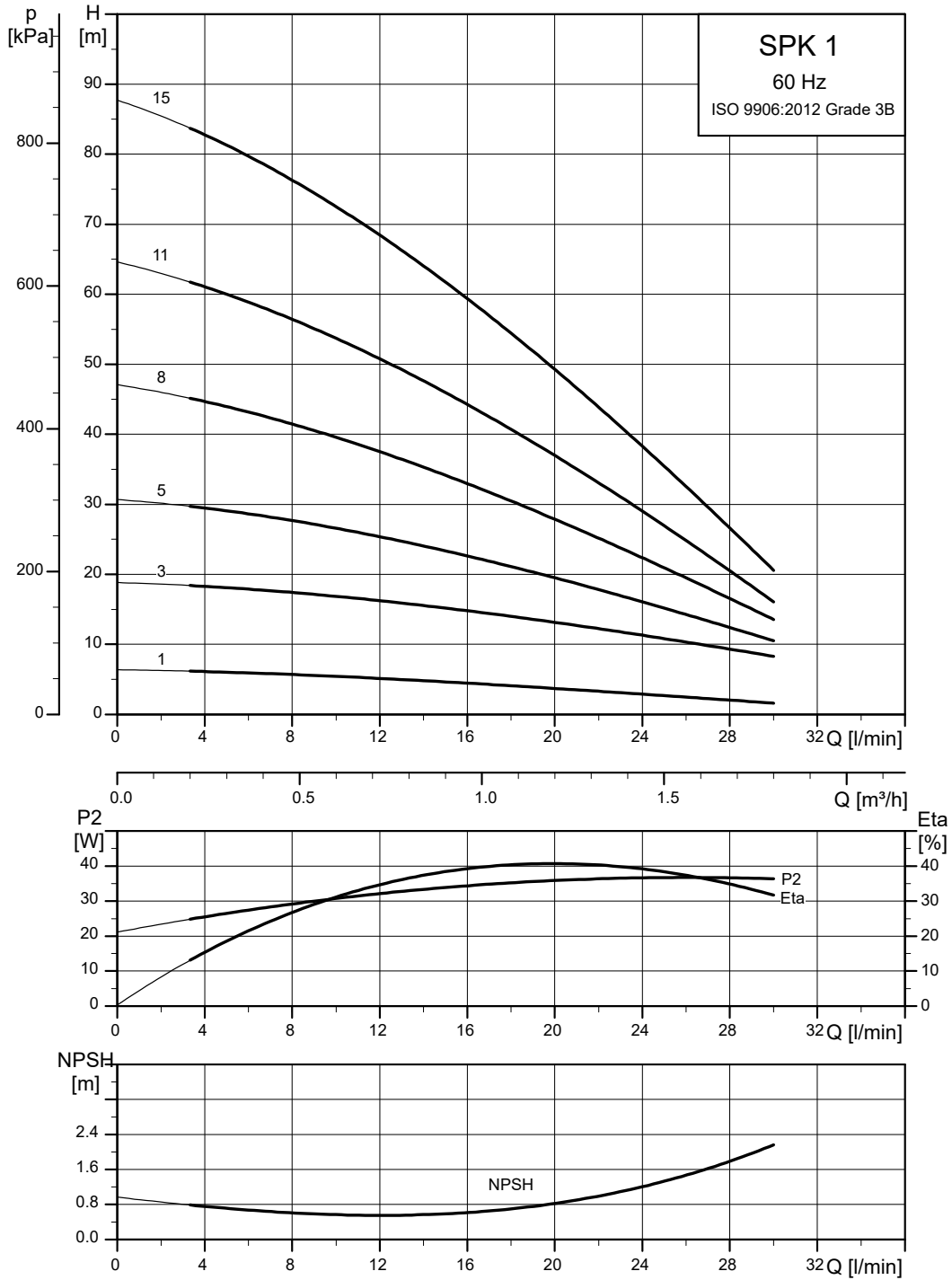

TM001931

Dimensional sketches

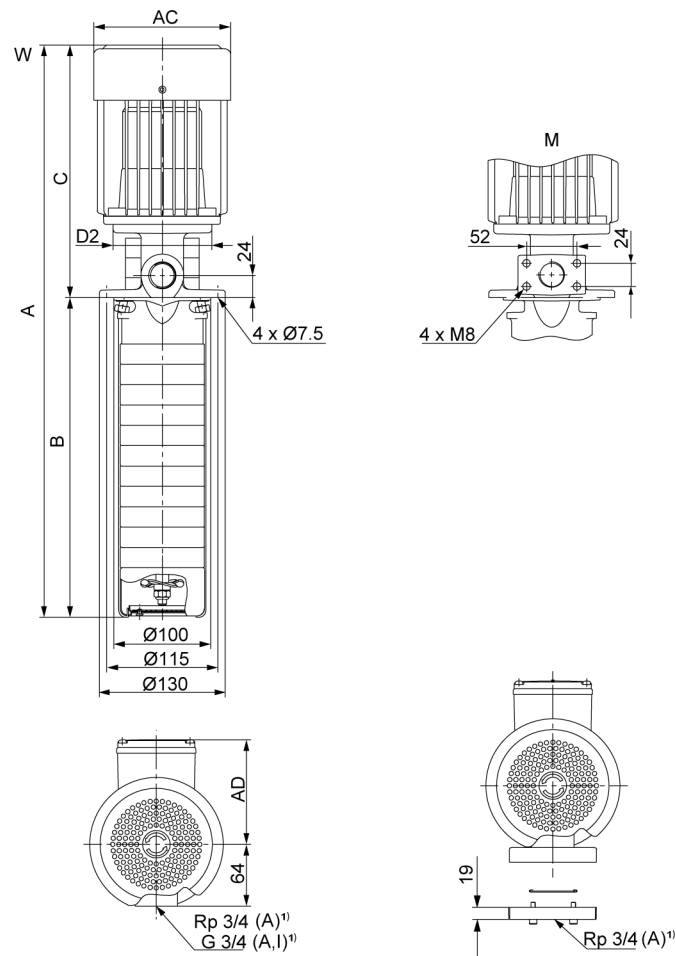

W: Internal thread connection. *M*: Square flange.

1) A: Basic version, cast iron. I: Stainless steel version.

Dimensions and weights

Pump type	P2 [kW]	Dimensions [mm]						Weight ²⁰⁾ [kg]
		A	B	C	AC	D2	AD	
SPK 1-1/1	0.06	395	140	255	124	90	101	9.3
SPK 1-3/3	0.12	437	182	255	124	90	101	8.7
SPK 1-5/5	0.25	479	224	255	141	90	109	9
SPK 1-8/8	0.25	533	287	246	141	102	109	11.8
SPK 1-11/11	0.37	617	350	267	141	102	109	12.8
SPK 1-15/15	0.55	701	434	267	141	102	109	13.4
SPK 1-19/15	0.55	785	518	267	141	102	109	13.8
SPK 1-23/15	0.55	869	602	267	141	102	109	14.3

²⁰⁾ The weights apply to the standard range (A-version). For the stainless steel versions (I-version), add 1 kg.

SPK with extension pipe

Pump type	P2 [kW]	Dimensions [mm]						Weight ²¹⁾ [kg]
		A	B	C	AC	D2	AD	
SPK 1-23/15	0.55	1272	1.005	267	141	102	109	19

²¹⁾ The weights apply to the standard range (A-version). For the stainless steel versions (I-version), add 1 kg.

For information about electrical data, see the section on electrical data.

TMC045801

SPK 2, 60 Hz

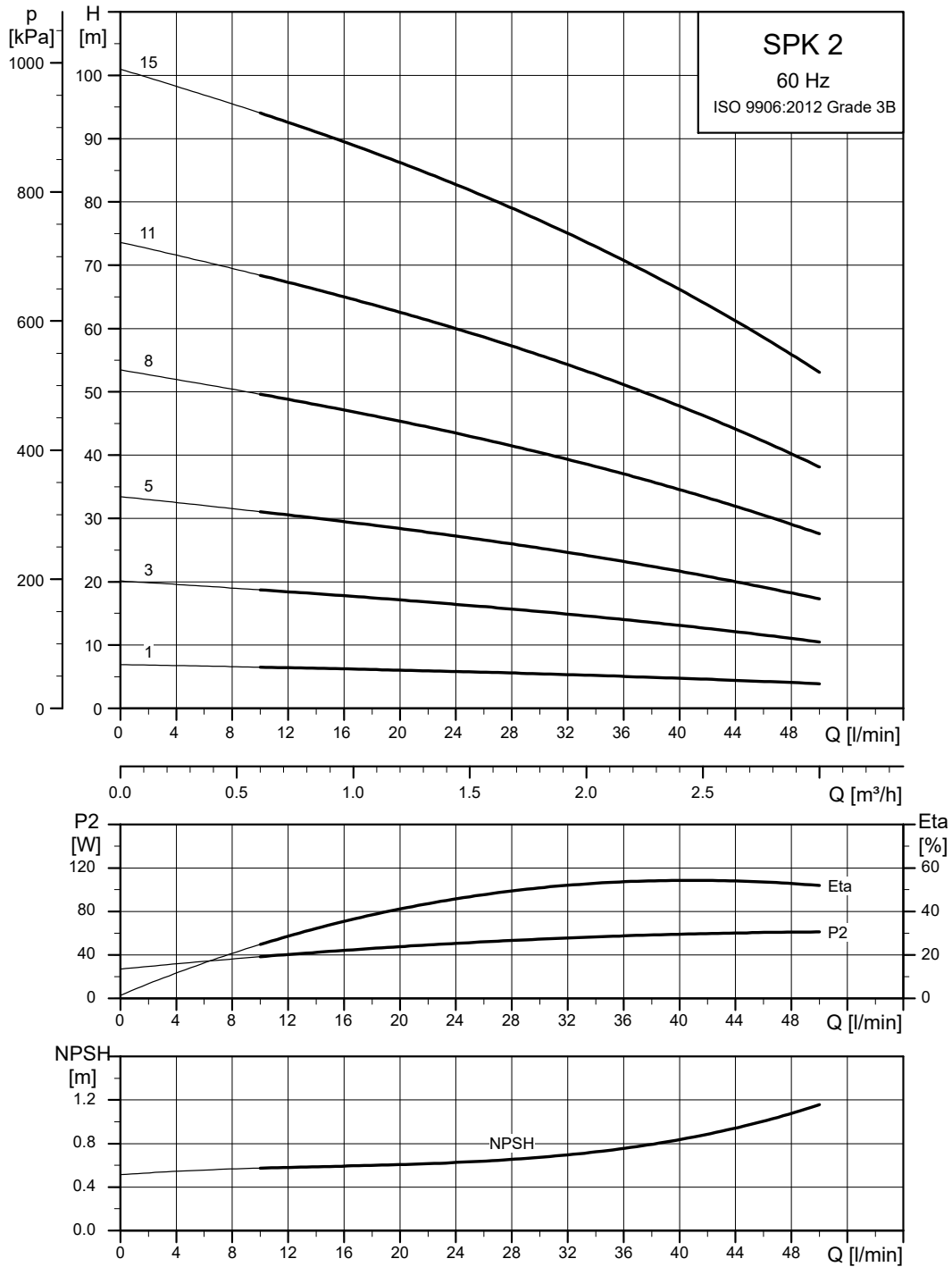

TM001933

Dimensional sketches

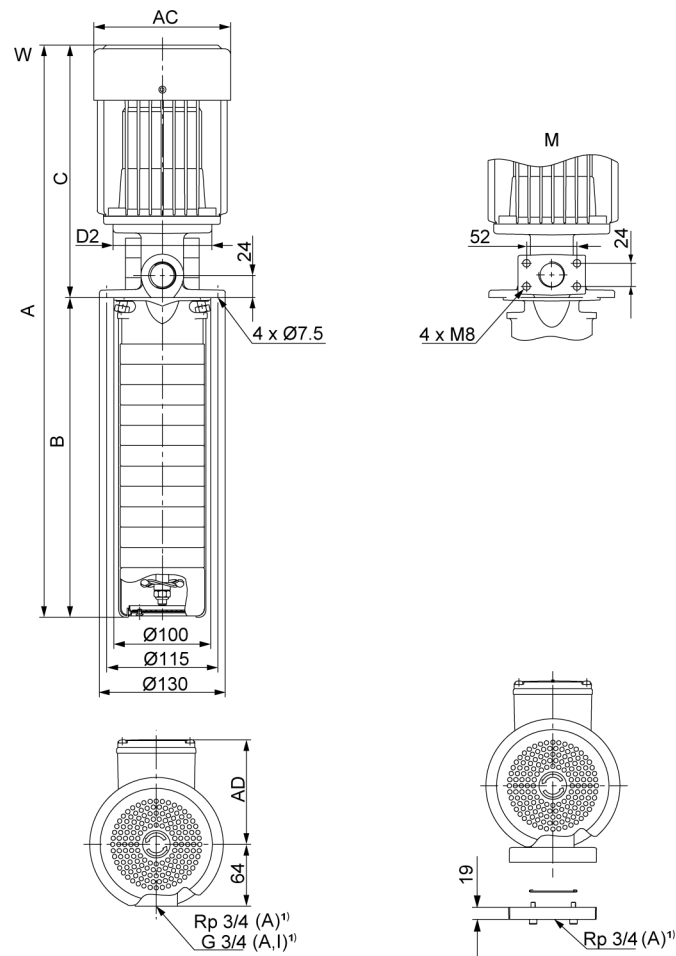

TMD45801

W: Internal thread connection. *M*: Square flange.

1) A: Basic version, cast iron. I: Stainless steel version.

Dimensions and weights

Pump type	P2 [kW]	Dimensions [mm]						Weight ²²⁾ [kg]
		A	B	C	AC	D2	AD	
SPK 2-1/1	0.06	395	140	255	124	90	101	9.3
SPK 2-3/3	0.25	437	182	255	141	90	109	8
SPK 2-5/5	0.37	491	224	267	141	102	109	11.2
SPK 2-8/8	0.55	554	287	267	141	102	109	11.5
SPK 2-11/11	0.75	657	350	307	141	120	109	14.9
SPK 2-15/15	1.1	761	434	327	141	120	109	18
SPK 2-19/15	1.1	845	518	327	141	120	109	18.5
SPK 2-23/15	1.1	929	602	327	141	120	109	18.9

²²⁾ The weights apply to the standard range (A-version). For the stainless steel versions (I-version), add 1 kg.

SPK with extension pipe

Pump type	P2 [kW]	Dimensions [mm]						Weight ²³⁾ [kg]
		A	B	C	AC	D2	AD	
SPK 2-23/15	1.1	1332	1005	327	141	120	109	23.6

²³⁾ The weights apply to the standard range (A-version). For the stainless steel versions (I-version), add 1 kg.

For information about electrical data, see the section on electrical data.

SPK 4, 60 Hz

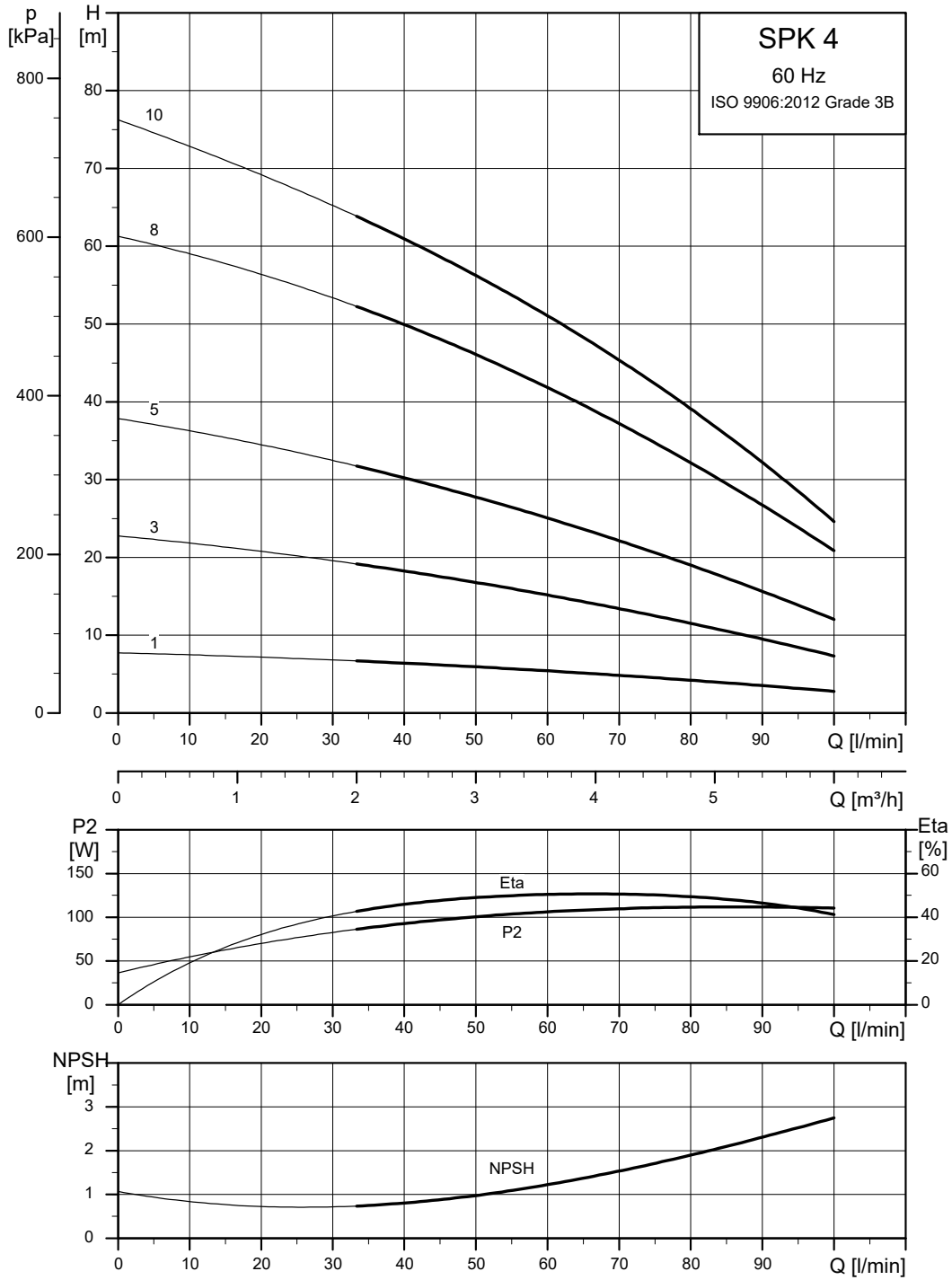

TM001935

Dimensional sketches

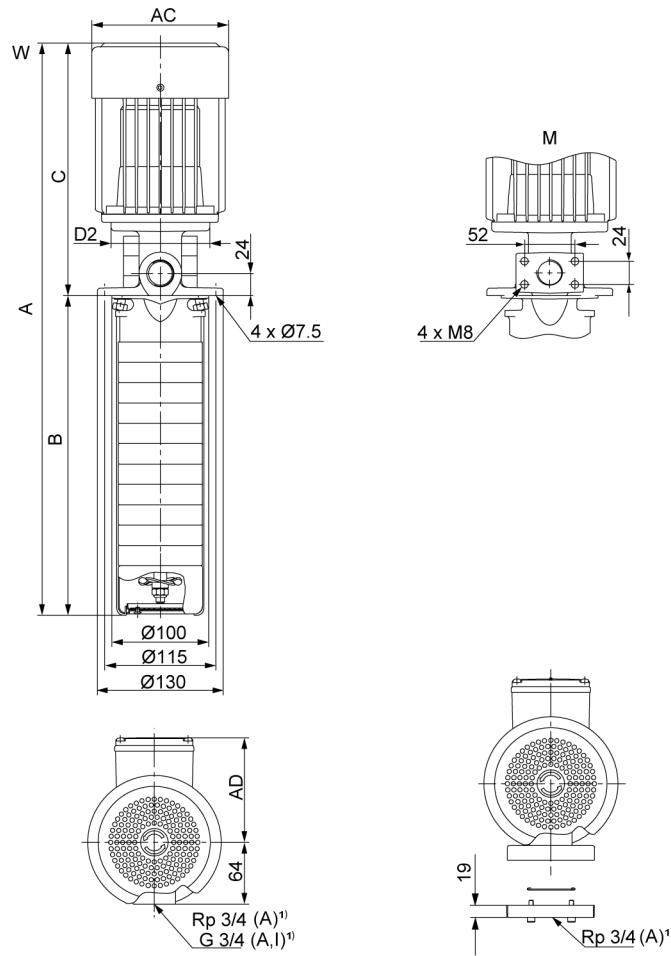

W: Internal thread connection. M: Square flange.

1) A: Basic version, cast iron. I: Stainless steel version.

Dimensions and weights

Pump type	P2 [kW]	Dimensions [mm]						Weight ²⁴⁾ [kg]
		A	B	C	AC	D2	AD	
SPK 4-1/1	0.12	395	140	255	124	90	101	8.3
SPK 4-3/3	0.37	449	182	267	141	102	109	10.5
SPK 4-5/5	0.55	491	224	267	141	102	109	10.2
SPK 4-8/8	1.1	614	287	327	141	120	109	15.2
SPK 4-11/10	1.1	677	350	327	141	120	109	15.5
SPK 4-15/10	1.1	761	434	327	141	120	109	16.1
SPK 4-19/10	1.1	845	518	327	141	120	109	16.6

²⁴⁾The weights apply to the standard range (A-version). For the stainless steel versions (I-version), add 1.3 kg.

SPK with extension pipe

Pump type	P2 [kW]	Dimensions [mm]						Weight ²⁵⁾ [kg]
		A	B	C	AC	D2	AD	
SPK 4-19/10	1.1	1332	1005	327	141	120	109	21.8

²⁵⁾The weights apply to the standard range (A-version). For the stainless steel versions (I-version), add 1.3 kg.

For information about electrical data, see the section on electrical data.

TMD45801

MTH, 50 Hz

MTH 2, 50 Hz

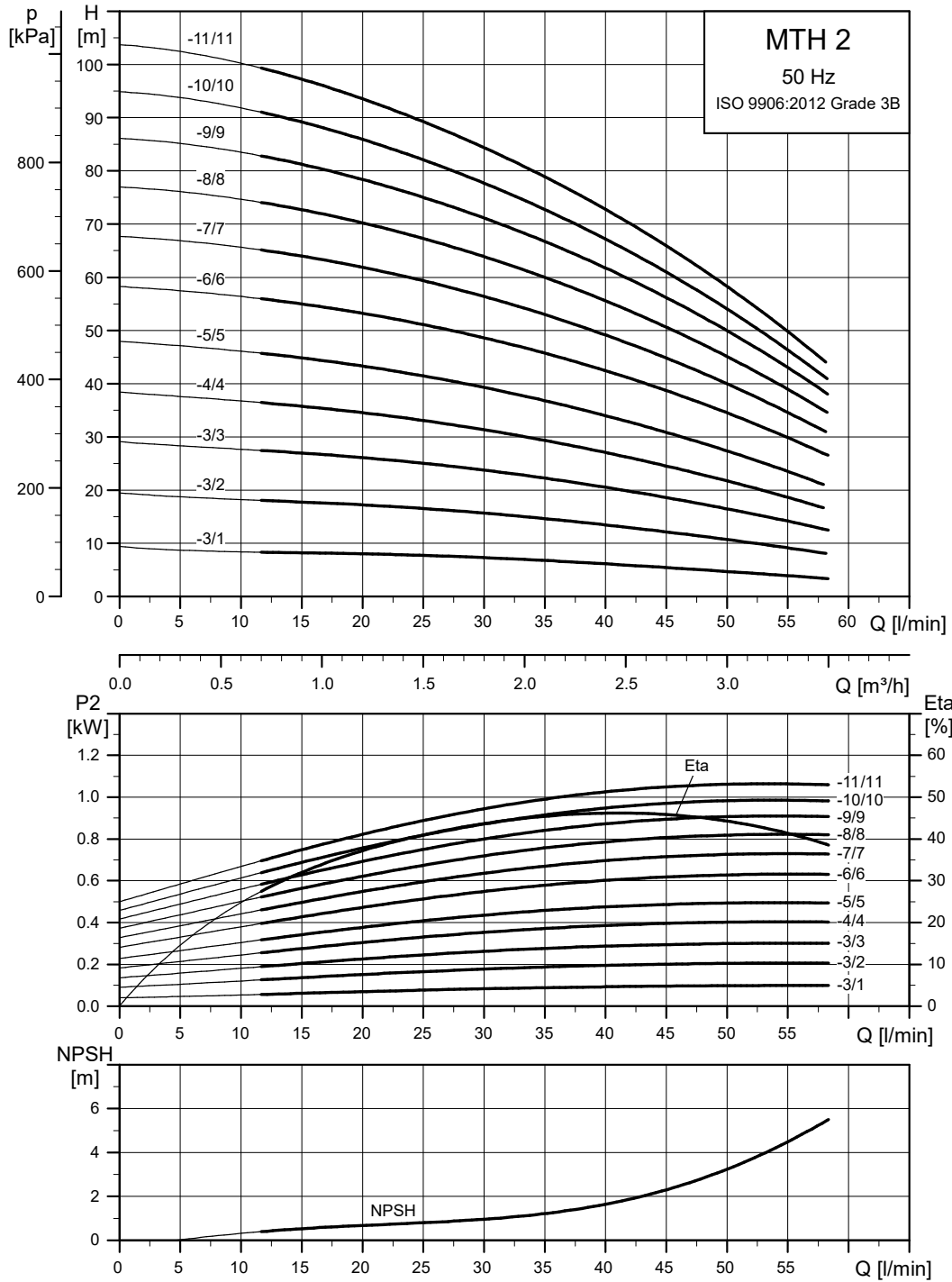

TM027824

Dimensional sketches

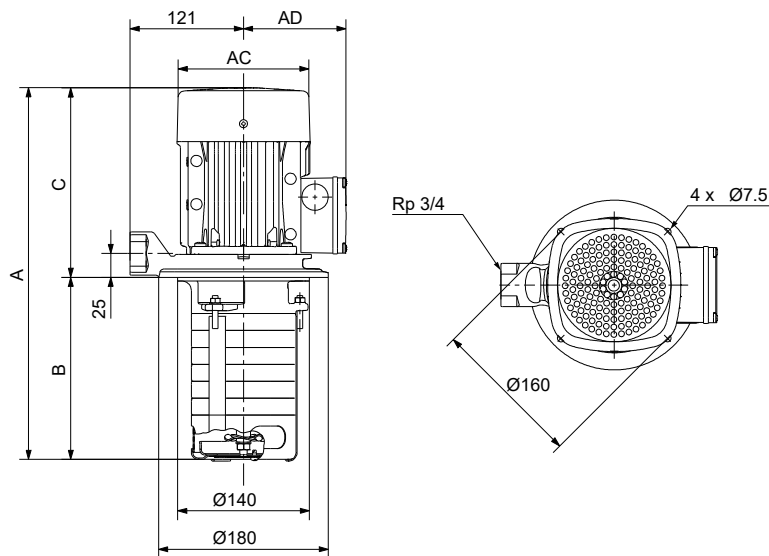

TM067672

Dimensions and weights

Pump type	Motor P2 [kW]	Dimensions [mm]					Weight [kg]
		A	B	C	AC	AD	
MTH 2-3/1	0.55	347	145	202	141	109	13/12.4 ²⁶⁾
MTH 2-3/2	0.55	347	145	202	141	109	13.1/12.5 ²⁶⁾
MTH 2-3/3	0.55	347	145	202	141	109	13.2/12.6 ²⁶⁾
MTH 2-4/1	0.55	365	163	202	141	109	13.3/12.7 ²⁶⁾
MTH 2-4/2	0.55	365	163	202	141	109	13.5/12.9 ²⁶⁾
MTH 2-4/3	0.55	365	163	202	141	109	13.6/13 ²⁶⁾
MTH 2-4/4	0.75	405	163	242	141	109	16.5/13.4 ²⁶⁾
MTH 2-5/1	0.55	383	181	202	141	109	13.7/13.1 ²⁶⁾
MTH 2-5/2	0.55	383	181	202	141	109	13.9/13.3 ²⁶⁾
MTH 2-5/3	0.55	383	181	202	141	109	14/13.4 ²⁶⁾
MTH 2-5/4	0.75	423	181	242	141	109	17/13.9 ²⁶⁾
MTH 2-5/5	0.75	423	181	242	141	109	17.1/14 ²⁶⁾
MTH 2-6/1	0.55	401	199	202	141	109	13.9/13.3 ²⁶⁾
MTH 2-6/2	0.55	401	199	202	141	109	14.2/13.6 ²⁶⁾
MTH 2-6/3	0.55	401	199	202	141	109	14.3/13.7 ²⁶⁾
MTH 2-6/4	0.75	441	199	242	141	109	17.3/14.2 ²⁶⁾
MTH 2-6/5	0.75	441	199	242	141	109	17.5/14.4 ²⁶⁾
MTH 2-6/6	1.1	461	199	262	141	109	15.5/15.2 ²⁶⁾
MTH 2-7/1	0.55	419	217	202	141	109	14.2/13.6 ²⁶⁾
MTH 2-7/2	0.55	419	217	202	141	109	14.4/13.8 ²⁶⁾
MTH 2-7/3	0.55	419	217	202	141	109	14.7/14.1 ²⁶⁾
MTH 2-7/4	0.75	459	217	242	141	109	17.7/14.6 ²⁶⁾
MTH 2-7/5	0.75	459	217	242	141	109	17.8/14.7 ²⁶⁾
MTH 2-7/6	1.1	479	217	262	141	109	16/15.6 ²⁶⁾
MTH 2-7/7	1.1	479	217	262	141	109	16.1/15.7 ²⁶⁾
MTH 2-8/1	0.55	437	235	202	141	109	14.4/13.8 ²⁶⁾
MTH 2-8/2	0.55	437	235	202	141	109	14.7/14.1 ²⁶⁾
MTH 2-8/3	0.55	437	235	202	141	109	14.9/14.3 ²⁶⁾
MTH 2-8/4	0.75	477	235	242	141	109	17.9/14.8 ²⁶⁾
MTH 2-8/5	0.75	477	235	242	141	109	18.1/15.1 ²⁶⁾
MTH 2-8/6	1.1	497	235	262	141	109	16.3/15.9 ²⁶⁾

Pump type	Motor P2 [kW]	Dimensions [mm]					Weight [kg]
		A	B	C	AC	AD	
MTH 2-8/7	1.1	497	235	262	141	109	16.5/16.1 ²⁶⁾
MTH 2-8/8	1.1	497	235	262	141	109	16.6/16.2 ²⁶⁾
MTH 2-9/1	0.55	455	253	202	141	109	14.6/14 ²⁶⁾
MTH 2-9/2	0.55	455	253	202	141	109	14.9/14.3 ²⁶⁾
MTH 2-9/3	0.55	455	253	202	141	109	15.1/14.5 ²⁶⁾
MTH 2-9/4	0.75	495	253	242	141	109	18.1/15 ²⁶⁾
MTH 2-9/5	0.75	495	253	242	141	109	18.4/15.3 ²⁶⁾
MTH 2-9/6	1.1	515	253	262	141	109	16.5/16.2 ²⁶⁾
MTH 2-9/7	1.1	515	253	262	141	109	16.8/16.4 ²⁶⁾
MTH 2-9/8	1.1	515	253	262	141	109	16.9/16.6 ²⁶⁾
MTH 2-9/9	1.1	515	253	262	141	109	17/13.3 ²⁶⁾
MTH 2-10/1	0.55	473	271	202	141	109	14.9/14.3 ²⁶⁾
MTH 2-10/2	0.55	473	271	202	141	109	15.1/14.5 ²⁶⁾
MTH 2-10/3	0.55	473	271	202	141	109	15.3/14.7 ²⁶⁾
MTH 2-10/4	0.75	513	271	242	141	109	18.4/15.3 ²⁶⁾
MTH 2-10/5	0.75	513	271	242	141	109	18.6/15.5 ²⁶⁾
MTH 2-10/6	1.1	533	271	262	141	109	16.8/16.4 ²⁶⁾
MTH 2-10/7	1.1	533	271	262	141	109	17/16.6 ²⁶⁾
MTH 2-10/8	1.1	533	271	262	141	109	17.2/16.9 ²⁶⁾
MTH 2-10/9	1.1	533	271	262	141	109	17.4/13.7 ²⁶⁾
MTH 2-10/10	1.1	533	271	262	141	109	17.5/13.8 ²⁶⁾
MTH 2-11/1	0.55	491	289	202	141	109	15.1/14.5 ²⁶⁾
MTH 2-11/2	0.55	491	289	202	141	109	15.3/14.7 ²⁶⁾
MTH 2-11/3	0.55	491	289	202	141	109	15.6/15 ²⁶⁾
MTH 2-11/4	0.75	531	289	242	141	109	18.6/15.5 ²⁶⁾
MTH 2-11/5	0.75	531	289	242	141	109	18.8/15.7 ²⁶⁾
MTH 2-11/6	1.1	551	289	262	141	109	17/16.6 ²⁶⁾
MTH 2-11/7	1.1	551	289	262	141	109	17.2/16.9 ²⁶⁾
MTH 2-11/8	1.1	551	289	262	141	109	17.5/17.1 ²⁶⁾
MTH 2-11/9	1.1	551	289	262	141	109	17.7/14 ²⁶⁾
MTH 2-11/10	1.1	551	289	262	141	109	17.9/14.2 ²⁶⁾
MTH 2-11/11	1.1	551	289	262	141	109	18/14.3 ²⁶⁾

²⁶⁾ Applies to pumps fitted with 200 V motors.

MTH 4, 50 Hz

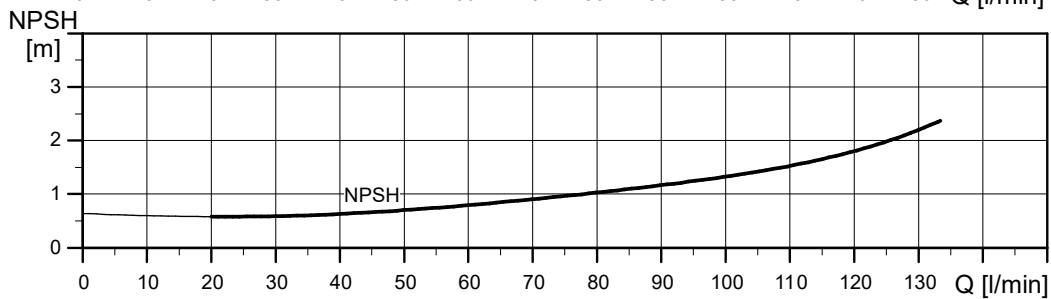
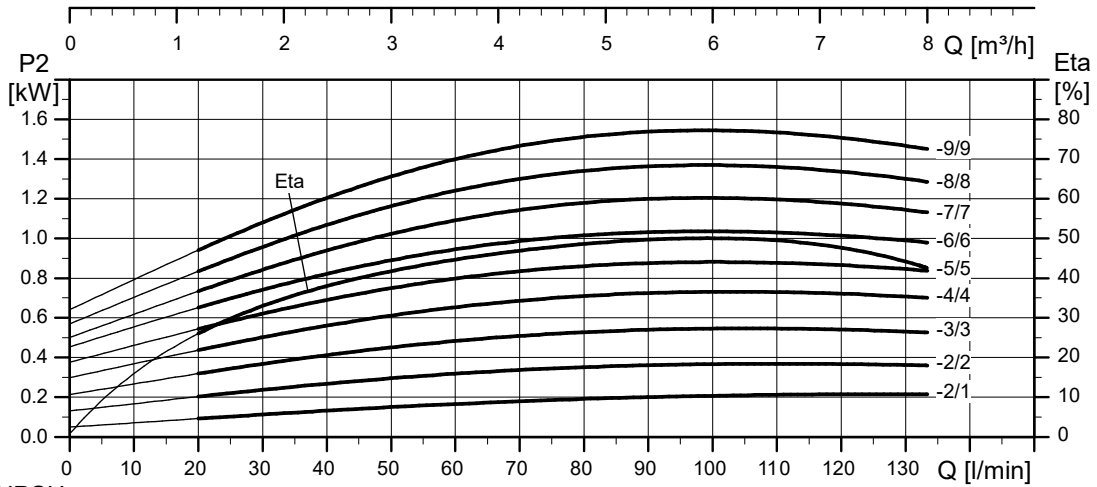
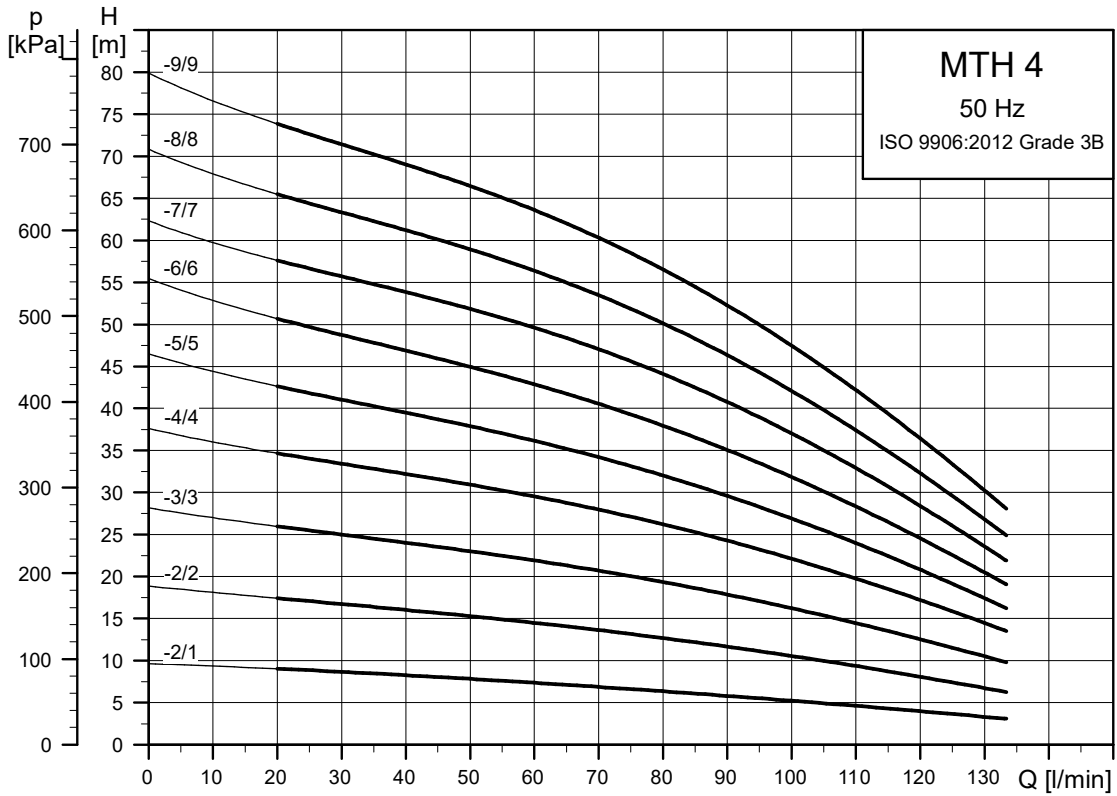

TM027825

Dimensional sketches

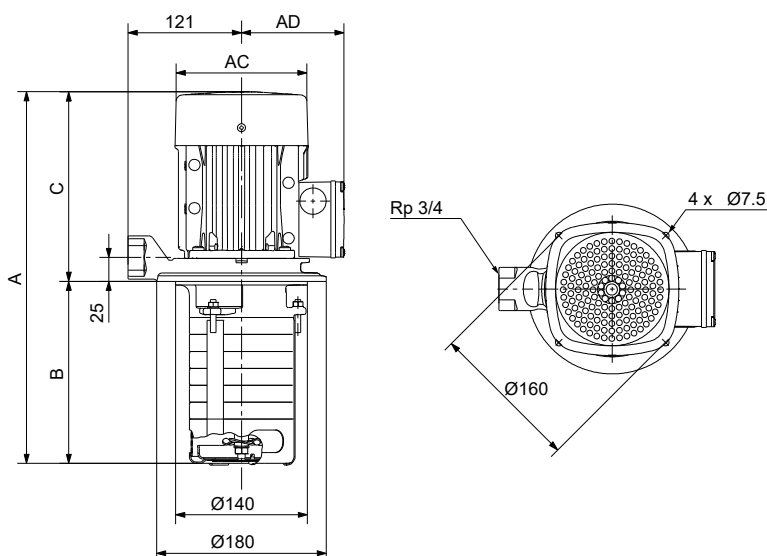

TM067672

Dimensions and weights

Pump type	Motor P2 [kW]	Dimensions [mm]					Weight [kg]
		A	B	C	AC	AD	
MTH 4-2/1	0.55	347	145	202	141	109	13.2/12.6 ²⁷⁾
MTH 4-2/2	0.55	347	145	202	141	109	13.3/12.7 ²⁷⁾
MTH 4-3/1	0.55	374	172	202	141	109	13.3/12.7 ²⁷⁾
MTH 4-3/2	0.55	374	172	202	141	109	13.4/12.8 ²⁷⁾
MTH 4-3/3	0.75	414	172	242	141	109	16.3/13.3 ²⁷⁾
MTH 4-4/1	0.55	401	199	202	141	109	13.6/13 ²⁷⁾
MTH 4-4/2	0.55	401	199	202	141	109	13.7/13.1 ²⁷⁾
MTH 4-4/3	0.75	441	199	242	141	109	16.7/13.6 ²⁷⁾
MTH 4-4/4	1.1	461	199	262	141	109	14.7/14.3 ²⁷⁾
MTH 4-5/1	0.55	428	226	202	141	109	13.7/13.1 ²⁷⁾
MTH 4-5/2	0.55	428	226	202	141	109	13.9/13.3 ²⁷⁾
MTH 4-5/3	0.75	468	226	242	141	109	16.8/13.7 ²⁷⁾
MTH 4-5/4	1.1	488	226	262	141	109	14.9/14.6 ²⁷⁾
MTH 4-5/5	1.1	488	226	262	141	109	15/11.3 ²⁷⁾
MTH 4-6/1	0.55	455	253	202	141	109	13.9/13.3 ²⁷⁾
MTH 4-6/2	0.55	455	253	202	141	109	14/13.4 ²⁷⁾
MTH 4-6/3	0.75	495	253	242	141	109	17/13.9 ²⁷⁾
MTH 4-6/4	1.1	515	253	262	141	109	15.1/14.7 ²⁷⁾
MTH 4-6/5	1.1	515	253	262	141	109	15.2/11.5 ²⁷⁾
MTH 4-6/6	1.1	515	253	262	141	109	15.3/11.6 ²⁷⁾
MTH 4-7/1	0.55	482	280	202	141	109	14.1/13.5 ²⁷⁾
MTH 4-7/2	0.55	482	280	202	141	109	14.2/13.6 ²⁷⁾
MTH 4-7/3	0.75	522	280	242	141	109	17.1/14 ²⁷⁾
MTH 4-7/4	1.1	542	280	262	141	109	15.2/14.9 ²⁷⁾
MTH 4-7/5	1.1	542	280	262	141	109	15.4/11.7 ²⁷⁾
MTH 4-7/6	1.1	542	280	262	141	109	15.5/11.8 ²⁷⁾
MTH 4-7/7	1.5	592/632 ²⁷⁾	280	312/352 ²⁷⁾	178	110	26.8/29.3 ²⁷⁾
MTH 4-8/1	0.55	509	307	202	141	109	14.2/13.6 ²⁷⁾
MTH 4-8/2	0.55	509	307	202	141	109	14.3/13.7 ²⁷⁾
MTH 4-8/3	0.75	549	307	242	141	109	17.3/14.2 ²⁷⁾
MTH 4-8/4	1.1	569	307	262	141	109	15.4/15 ²⁷⁾

Pump type	Motor P2 [kW]	Dimensions [mm]					Weight [kg]
		A	B	C	AC	AD	
MTH 4-8/5	1.1	569	307	262	141	109	15.5/11.8 ²⁷⁾
MTH 4-8/6	1.1	569	307	262	141	109	15.7/12 ²⁷⁾
MTH 4-8/7	1.5	619/659 ²⁷⁾	307	312/352 ²⁷⁾	178	110	27/29.5 ²⁷⁾
MTH 4-8/8	1.5	619/659 ²⁷⁾	307	312/352 ²⁷⁾	178	110	27.1/29.6 ²⁷⁾
MTH 4-9/1	0.55	536	334	202	141	109	14.5/13.9 ²⁷⁾
MTH 4-9/2	0.55	536	334	202	141	109	14.7/14.1 ²⁷⁾
MTH 4-9/3	0.75	576	334	242	141	109	17.6/14.5 ²⁷⁾
MTH 4-9/4	1.1	596	334	262	141	109	15.7/15.4 ²⁷⁾
MTH 4-9/5	1.1	596	334	262	141	109	15.9/12.2 ²⁷⁾
MTH 4-9/6	1.1	596	334	262	141	109	16/12.3 ²⁷⁾
MTH 4-9/7	1.5	646/686 ²⁷⁾	334	312/352 ²⁷⁾	178	110	27.3/29.8 ²⁷⁾
MTH 4-9/8	1.5	646/686 ²⁷⁾	334	312/352 ²⁷⁾	178	110	27.5/29.9 ²⁷⁾
MTH 4-9/9	2.2	686	334	352	178	110	31.7/31.7 ²⁷⁾

²⁷⁾Applies to pumps fitted with 200 V motors.

MTH 8, 50 Hz

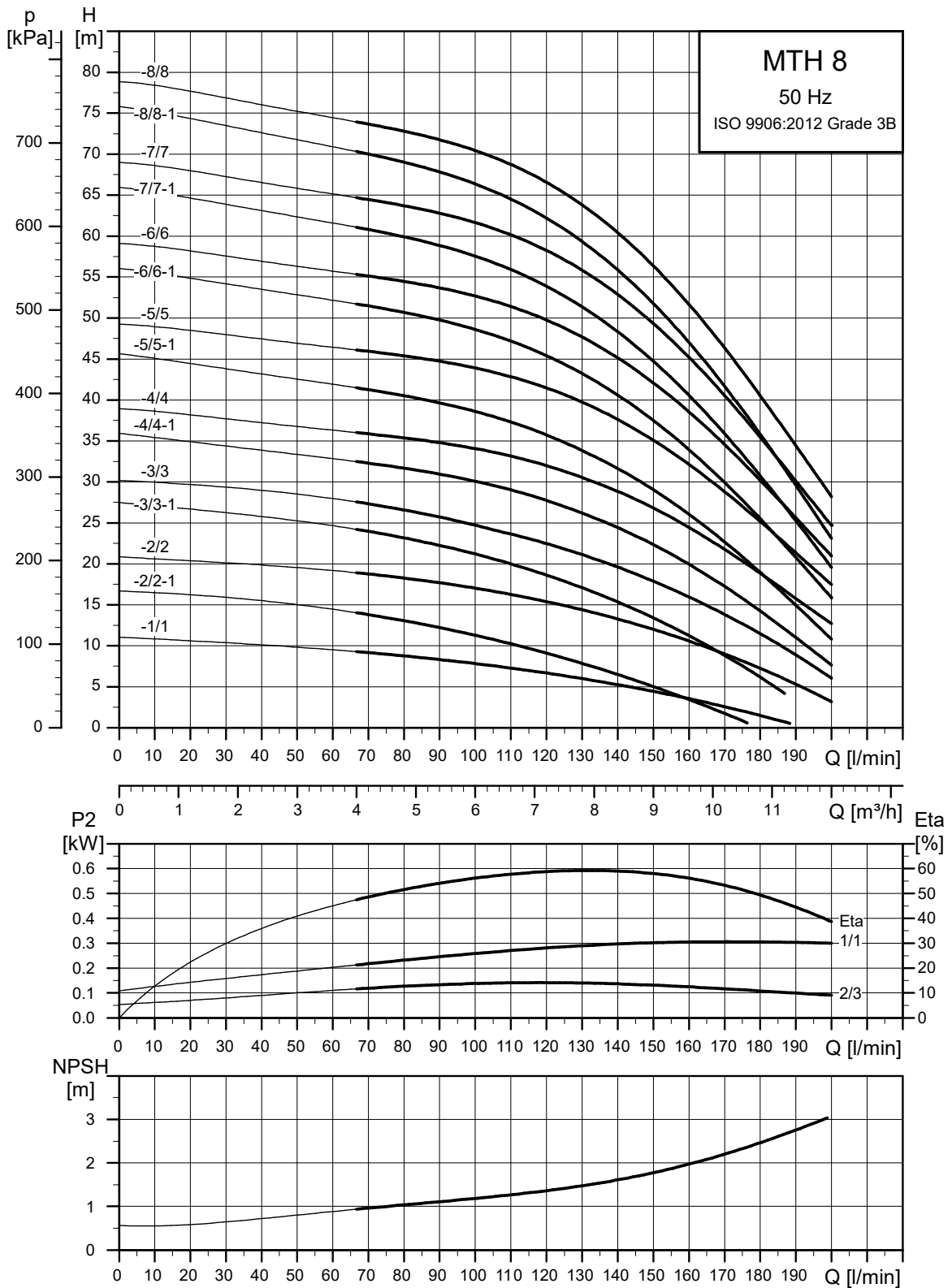

TM062361

Dimensional sketches

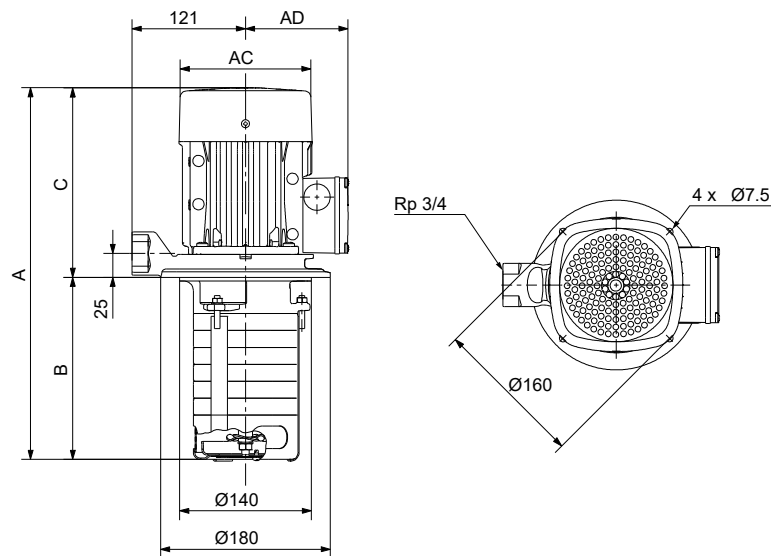

TM067672

Dimensions and weights

Pump type	Motor P2 [kW]	Dimensions [mm]					Weight [kg]
		A	B	C	AC	AD	
MTH 8-1/1	0.55	347	145	202	141	109	12.5/11.9 ²⁸⁾
MTH 8-2/1	0.55	374	172	202	141	109	12.7/12.1 ²⁸⁾
MTH 8-2/2-1	0.55	374	172	202	141	109	12.8/12.2 ²⁸⁾
MTH 8-2/2	0.75	414	172	242	141	109	15.7/12.6 ²⁸⁾
MTH 8-3/1	0.55	401	199	202	141	109	12.9/12.3 ²⁸⁾
MTH 8-3/2-1	0.55	401	199	202	141	109	13/12.4 ²⁸⁾
MTH 8-3/2	0.75	441	199	242	141	109	15.9/12.8 ²⁸⁾
MTH 8-3/3-1	0.75	441	199	242	141	109	16.1/13 ²⁸⁾
MTH 8-3/3	1.1	461	199	262	141	109	14.1/10.4 ²⁸⁾
MTH 8-4/1	0.55	428	226	202	141	109	13/12.4 ²⁸⁾
MTH 8-4/2-1	0.55	428	226	202	141	109	13.1/12.5 ²⁸⁾
MTH 8-4/2	0.75	468	226	242	141	109	16/12.9 ²⁸⁾
MTH 8-4/3-1	0.75	468	226	242	141	109	16.2/13.1 ²⁸⁾
MTH 8-4/3	1.1	488	226	262	141	109	14.2/10.5 ²⁸⁾
MTH 8-4/4-1	1.1	488	226	262	141	109	14.4/10.7 ²⁸⁾
MTH 8-4/4	1.5	538/578 ²⁸⁾	226	312/352 ²⁸⁾	178	110	25.6/28.1 ²⁸⁾
MTH 8-5/1	0.55	455	253	202	141	109	13.2/12.6 ²⁸⁾
MTH 8-5/2-1	0.55	455	253	202	141	109	13.3/12.7 ²⁸⁾
MTH 8-5/2	0.75	495	253	242	141	109	16.2/13.1 ²⁸⁾
MTH 8-5/3-1	0.75	495	253	242	141	109	16.4/13.3 ²⁸⁾
MTH 8-5/3	1.1	515	253	262	141	109	14.4/10.7 ²⁸⁾
MTH 8-5/4-1	2.2	605	253	352	178	110	29.9/28.6 ²⁸⁾
MTH 8-5/4	1.5	565/605 ²⁸⁾	253	312/352 ²⁸⁾	178	110	25.8/28.3 ²⁸⁾
MTH 8-5/5-1	1.5	565/605 ²⁸⁾	253	312/352 ²⁸⁾	178	110	26/28.4 ²⁸⁾
MTH 8-5/5	2.2	605	253	352	178	110	30.1/30.1 ²⁸⁾
MTH 8-6/1	0.55	482	280	202	141	109	13.3/12.7 ²⁸⁾
MTH 8-6/2-1	0.55	482	280	202	141	109	13.5/12.9 ²⁸⁾
MTH 8-6/2	0.75	522	280	242	141	109	16.4/13.3 ²⁸⁾
MTH 8-6/3-1	0.75	522	280	242	141	109	16.6/13.5 ²⁸⁾
MTH 8-6/3	1.1	542	280	262	141	109	14.6/10.9 ²⁸⁾
MTH 8-6/4-1	1.1	542	280	262	141	109	14.7/11 ²⁸⁾

Pump type	Motor P2 [kW]	Dimensions [mm]					Weight [kg]
		A	B	C	AC	AD	
MTH 8-6/4	1.5	592/632 ²⁸⁾	280	312/352 ²⁸⁾	178	110	26/28.4 ²⁸⁾
MTH 8-6/5-1	1.5	592/632 ²⁸⁾	280	312/352 ²⁸⁾	178	110	26.2/28.6 ²⁸⁾
MTH 8-6/5	2.2	632	280	352	178	110	30.3/30.3 ²⁸⁾
MTH 8-6/6-1	2.2	632	280	352	178	110	30.5/30.5 ²⁸⁾
MTH 8-6/6	2.2	632	280	352	178	110	30.5/30.5 ²⁸⁾
MTH 8-7/1	0.55	509	307	202	141	109	13.5/12.9 ²⁸⁾
MTH 8-7/2-1	0.55	509	307	202	141	109	13.6/13 ²⁸⁾
MTH 8-7/2	0.75	549	307	242	141	109	16.5/13.4 ²⁸⁾
MTH 8-7/3-1	0.75	549	307	242	141	109	16.7/13.6 ²⁸⁾
MTH 8-7/3	1.1	569	307	262	141	109	14.7/11 ²⁸⁾
MTH 8-7/4-1	1.1	569	307	262	141	109	14.9/11.2 ²⁸⁾
MTH 8-7/4	1.5	619/659 ²⁸⁾	307	312/352 ²⁸⁾	178	110	26.1/28.6 ²⁸⁾
MTH 8-7/5-1	1.5	619/659 ²⁸⁾	307	312/352 ²⁸⁾	178	110	26.3/28.8 ²⁸⁾
MTH 8-7/5	2.2	659	307	352	178	110	30.4/30.4 ²⁸⁾
MTH 8-7/6-1	2.2	659	307	352	178	110	30.6/30.6 ²⁸⁾
MTH 8-7/6	2.2	659	307	352	178	110	30.7/30.6 ²⁸⁾
MTH 8-7/7-1	2.2	659	307	352	178	110	30.9/30.8 ²⁸⁾
MTH 8-7/7	2.2	659	307	352	178	110	30.9/30.9 ²⁸⁾
MTH 8-8/1	0.55	536	334	202	141	109	13.8/13.2 ²⁸⁾
MTH 8-8/2-1	0.55	536	334	202	141	109	13.9/13.3 ²⁸⁾
MTH 8-8/2	0.75	576	334	242	141	109	16.8/13.7 ²⁸⁾
MTH 8-8/3-1	0.75	576	334	242	141	109	17/13.9 ²⁸⁾
MTH 8-8/3	1.1	596	334	262	141	109	15/11.3 ²⁸⁾
MTH 8-8/4-1	1.1	596	334	262	141	109	15.2/11.5 ²⁸⁾
MTH 8-8/4	1.5	646/686 ²⁸⁾	334	312/352 ²⁸⁾	178	110	26.4/28.9 ²⁸⁾
MTH 8-8/5-1	1.5	646/686 ²⁸⁾	334	312/352 ²⁸⁾	178	110	26.6/29.1 ²⁸⁾
MTH 8-8/5	2.2	686	334	352	178	110	30.8/30.7 ²⁸⁾
MTH 8-8/6-1	2.2	686	334	352	178	110	31/30.9 ²⁸⁾
MTH 8-8/6	2.2	686	334	352	178	110	31/31 ²⁸⁾
MTH 8-8/7-1	2.2	686	334	352	178	110	31.2/31.2 ²⁸⁾
MTH 8-8/7	2.2	686	334	352	178	110	31.2/31.2 ²⁸⁾
MTH 8-8/8-1	3	704	334	370	198	120	35.1/38 ²⁸⁾
MTH 8-8/8	3	704	334	370	198	120	35.2/38 ²⁸⁾

²⁸⁾ Applies to pumps fitted with 200 V motors

MTH 10, 50 Hz

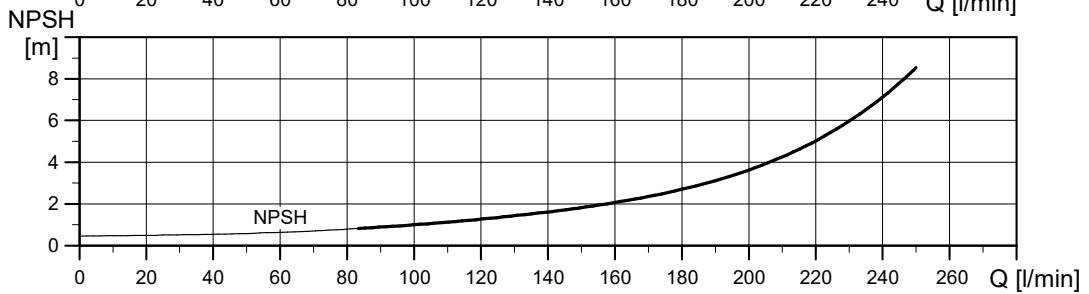
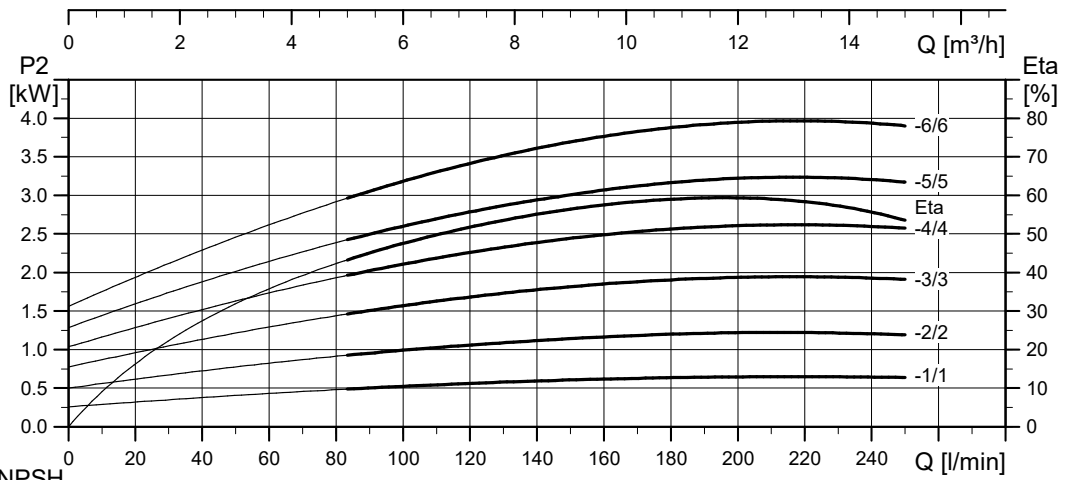
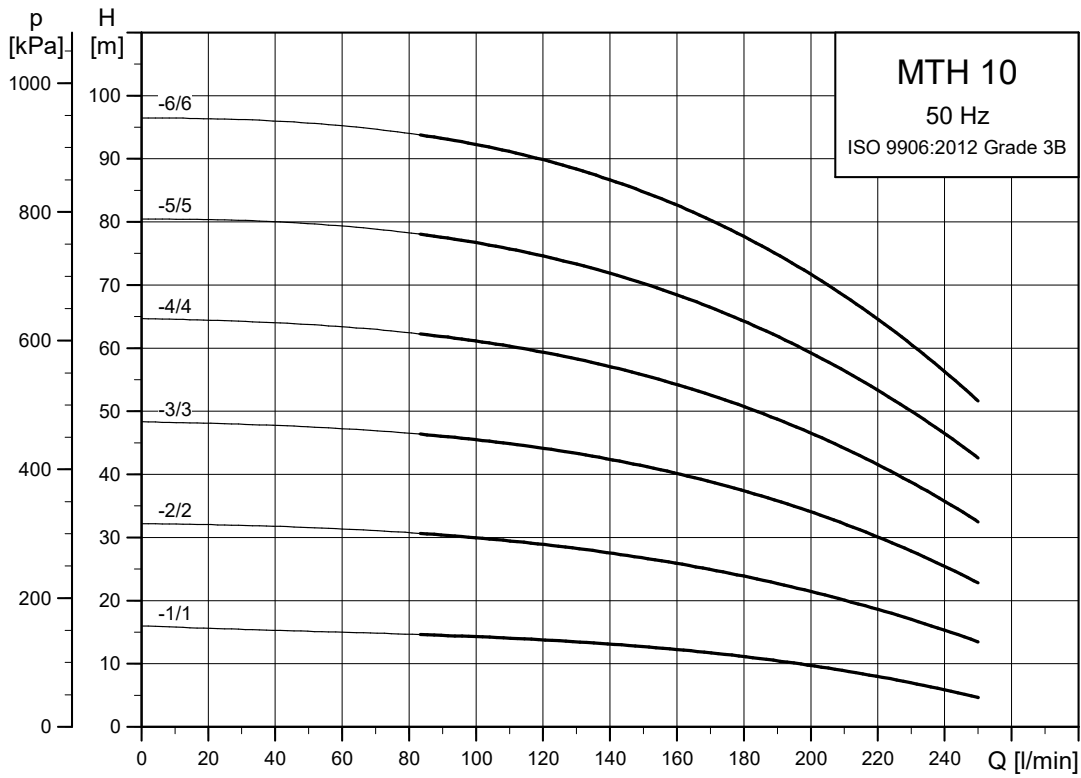

TMC68919

Dimensional sketches

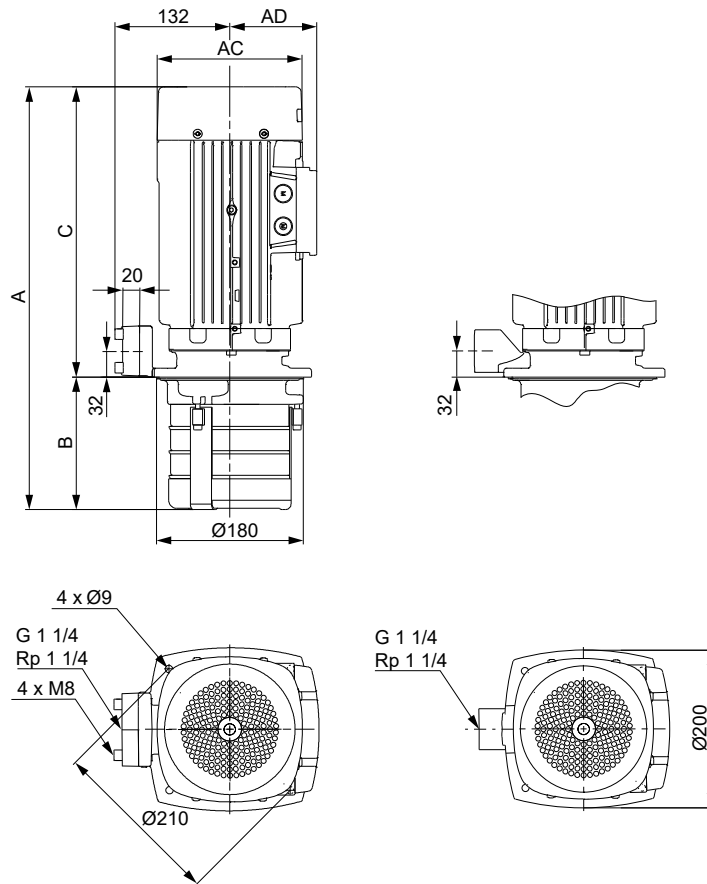

A-version (left), I-version (right).

Dimensions and weights

Pump type	Motor P2 [kW]	MT					Net weight [kg]
		Dimensions [mm]					
		A	B	C	AC	AD	
MTH 10-1/1	1.1	375	105	270	141	109	17.3/17.2 ²⁹⁾
MTH 10-2/1	1.1	405	135	270	141	109	17.8/17.5 ²⁹⁾
MTH 10-2/2	1.1	405	135	270	141	109	18.5/15.6 ²⁹⁾
MTH 10-3/1	1.1	435	165	270	141	109	18.1/17.8 ²⁹⁾
MTH 10-3/2	1.1	435	165	270	141	109	19/16.1 ²⁹⁾
MTH 10-3/3	2.2	525	165	360	178	110	32.9/32.8 ²⁹⁾
MTH 10-4/1	1.1	465	195	270	141	109	17.9/17.6 ²⁹⁾
MTH 10-4/2	1.1	465	195	270	141	109	18.8/15.9 ²⁹⁾
MTH 10-4/3	2.2	555	195	360	178	110	32.9/32.8 ²⁹⁾
MTH 10-4/4	3	572	195	377	198	120	38.1/40.9 ²⁹⁾
MTH 10-5/1	1.1	495	225	270	141	109	18.3/17.9 ²⁹⁾
MTH 10-5/2	1.1	495	225	270	141	109	19.1/16.2 ²⁹⁾
MTH 10-5/3	2.2	585	225	360	178	110	33.2/33.2 ²⁹⁾
MTH 10-5/4	3	602	225	377	198	120	38.6/41.4 ²⁹⁾
MTH 10-5/5	3	602	225	377	198	120	39.2/42.1 ²⁹⁾
MTH 10-6/1	1.1	525	255	270	141	109	18.7/18.3 ²⁹⁾
MTH 10-6/2	1.1	525	255	270	141	109	19.6/16.6 ²⁹⁾

TM069507

Pump type	MT						Net weight [kg]
	Motor P2 [kW]	Dimensions [mm]					
		A	B	C	AC	AD	
MTH 10-6/3	2.2	615	255	360	178	110	33.7/33.7 ²⁹⁾
MTH 10-6/4	3	632	255	377	198	120	39/41.8 ²⁹⁾
MTH 10-6/5	3	632	255	377	198	120	39.9/42.7 ²⁹⁾
MTH 10-6/6	4	668	255	413	220	134	43.1/43.4 ²⁹⁾

²⁹⁾Applies to pumps fitted with 200 V motors.

MTH 15, 50 Hz

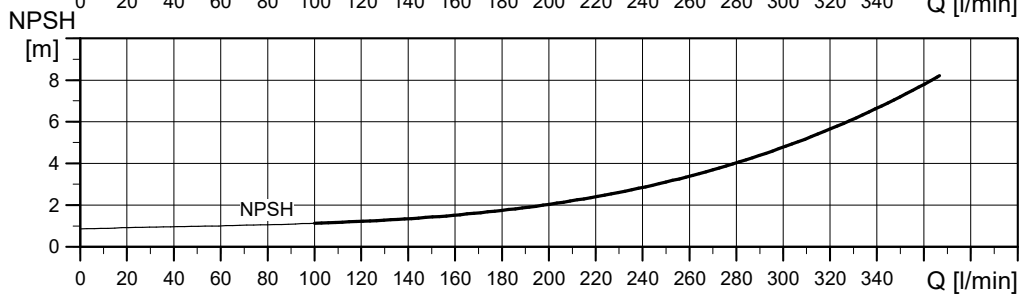
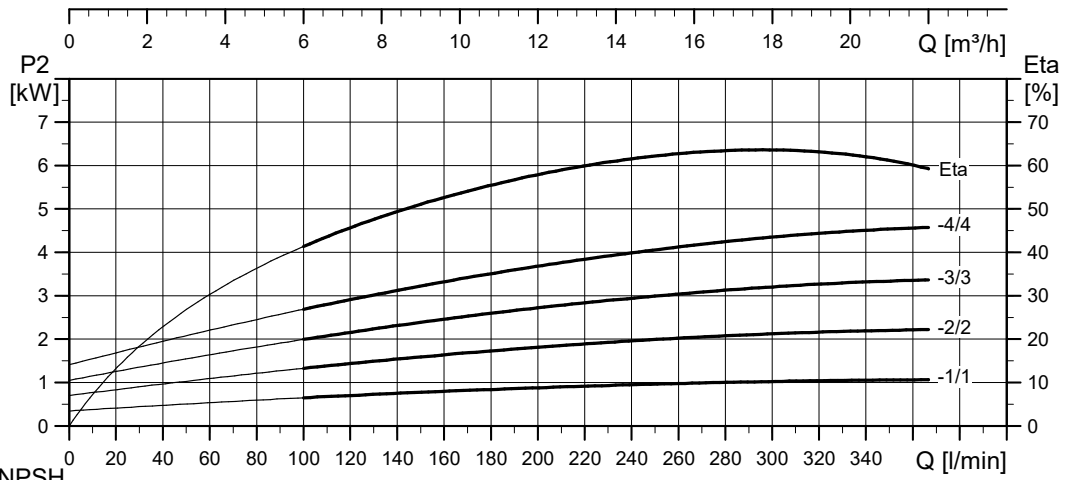
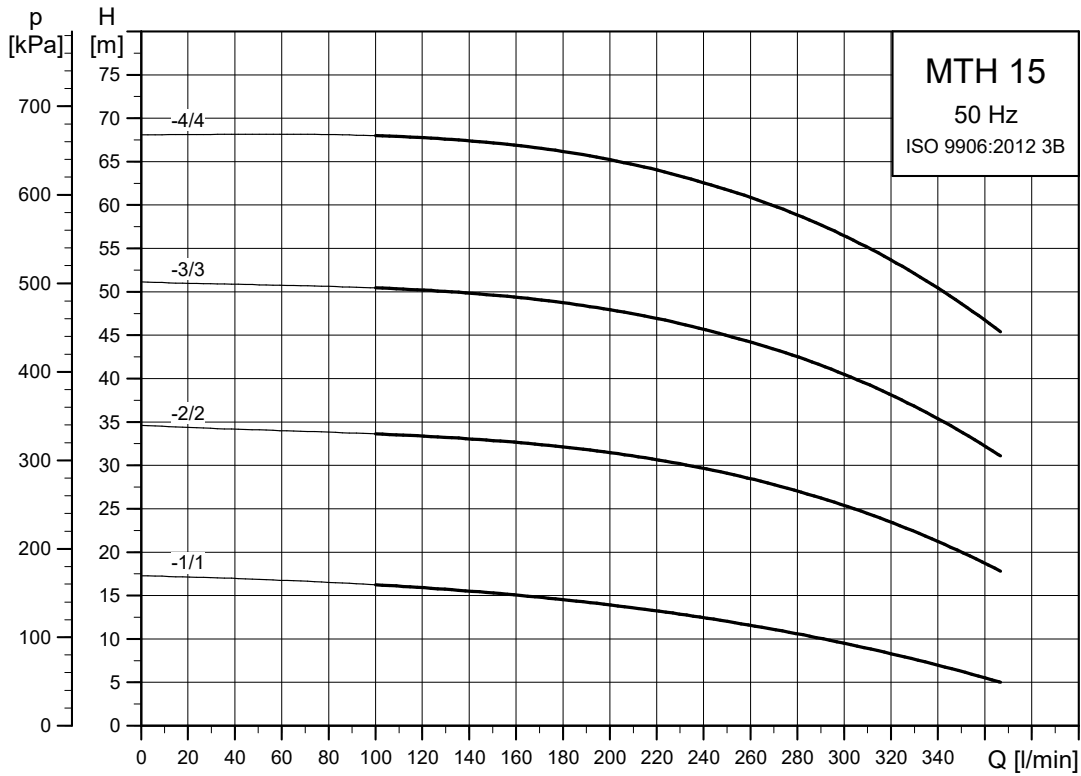

TM068921

Dimensional sketches

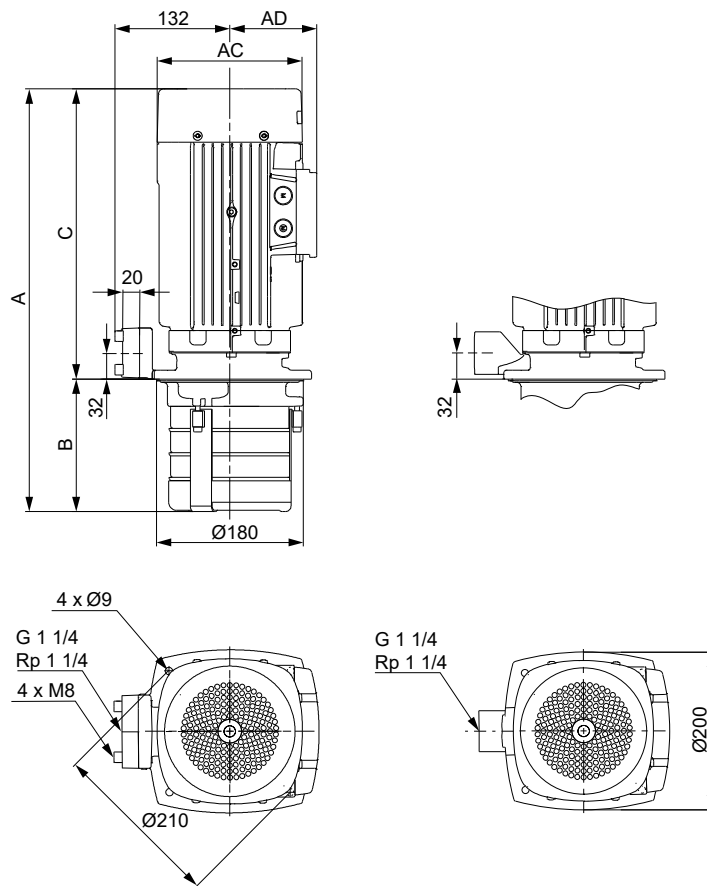

TM069507

A-version (left), I-version (right).

Dimensions and weights

Pump type	Motor P2 [kW]	MT					Net weight [kg]
		Dimensions [mm]					
		A	B	C	AC	AD	
MTH 15-1/1	1.10	405	135	270	141	109	17.3/14.4 ³⁰⁾
MTH 15-2/1	1.10	405	135	270	141	109	17.8/14.9 ³⁰⁾
MTH 15-2/2	2.20	495	135	360	178	110	31.7/31.6 ³⁰⁾
MTH 15-3/1	1.10	435	165	270	141	109	18.1/15.2 ³⁰⁾
MTH 15-3/2	2.20	525	165	360	178	110	32.2/32.2 ³⁰⁾
MTH 15-3/3	3	542	165	377	198	120	37.4/40.2 ³⁰⁾
MTH 15-4/1	1.10	465	195	270	141	109	17.9/15 ³⁰⁾
MTH 15-4/2	2.20	555	195	360	178	110	32/32 ³⁰⁾
MTH 15-4/3	3	572	195	377	198	120	37.4/40.2 ³⁰⁾
MTH 15-4/4	4	608	195	413	220	134	40.6/40.9 ³⁰⁾
MTH 15-5/1	1.10	495	225	270	141	109	18.3/15.3 ³⁰⁾
MTH 15-5/2	2.20	585	225	360	178	110	32.3/32.3 ³⁰⁾
MTH 15-5/3	3	602	225	377	198	120	37.7/40.5 ³⁰⁾
MTH 15-5/4	4	638	225	413	220	134	41.1/41.4 ³⁰⁾

Pump type	MT						Net weight [kg]
	Motor P2 [kW]	Dimensions [mm]				AD	
		A	B	C	AC		
MTH 15-6/1	1.10	525	255	270	141	109	18.7/15.8 ³⁰⁾
MTH 15-6/2	2.20	615	255	360	178	110	32.8/32.8 ³⁰⁾
MTH 15-6/3	3	632	255	377	198	120	38.1/41 ³⁰⁾
MTH 15-6/4	4	668	255	413	220	134	41.5/41.8 ³⁰⁾

³⁰⁾Applies to pumps fitted with 200 V motors.

MTH, 60 Hz

MTH 2, 60 Hz

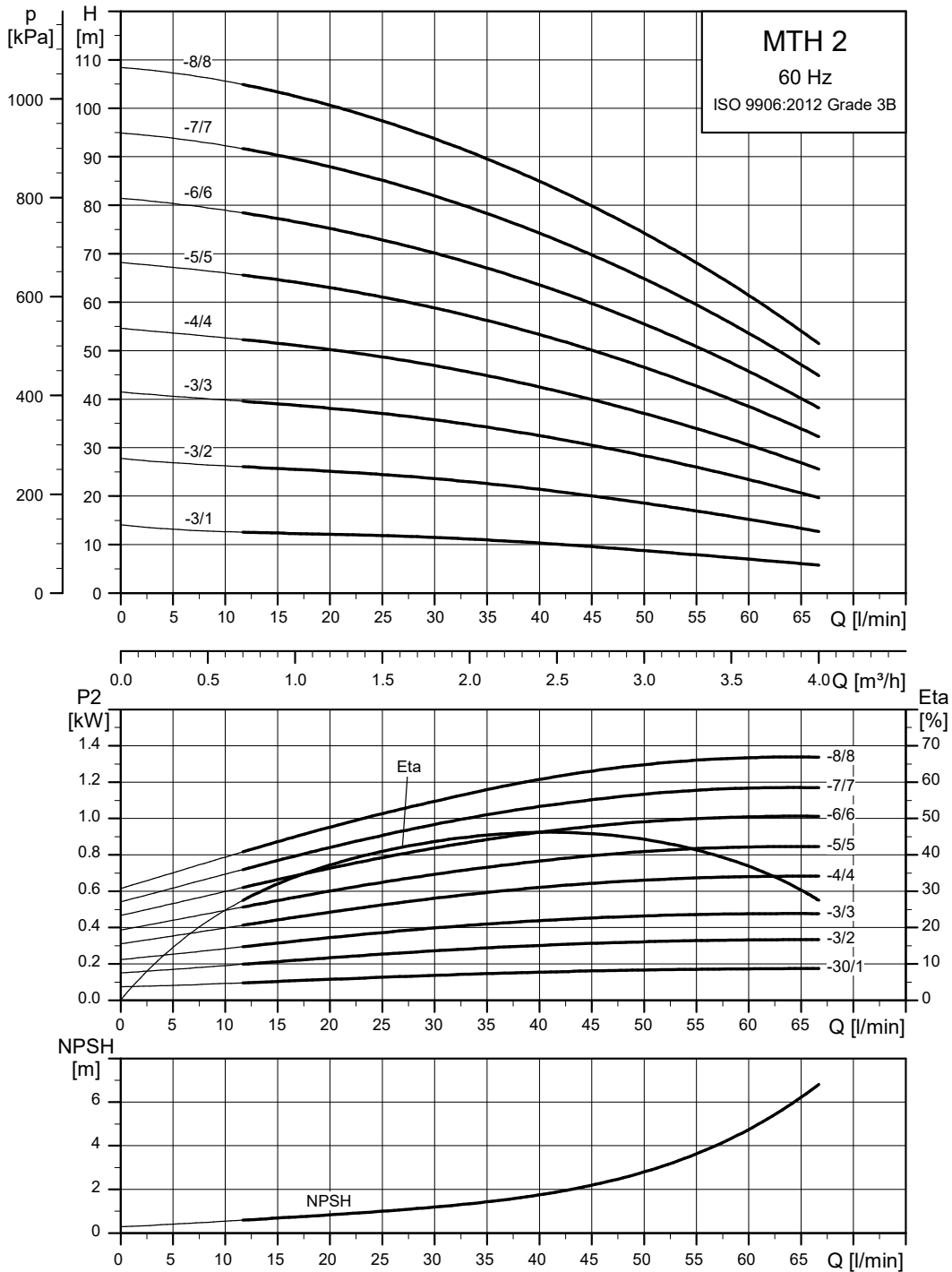

TM027826

Dimensional sketches

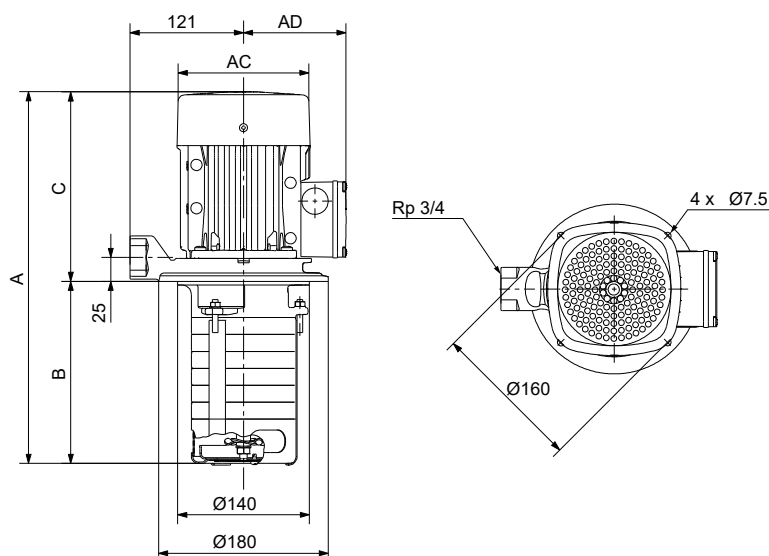

TM067672

Dimensions and weights

Pump type	Motor P2 [kW]	Dimensions [mm]					Weight [kg]
		A	B	C	AC	AD	
MTH 2-3/1	0.55	347	145	202	141	109	13/12.4 ³¹⁾
MTH 2-3/2	0.55	347	145	202	141	109	13.1/12.5 ³¹⁾
MTH 2-3/3	0.55	347	145	202	141	109	13.2/12.6 ³¹⁾
MTH 2-4/1	0.55	365	163	202	141	109	13.3/12.7 ³¹⁾
MTH 2-4/2	0.55	365	163	202	141	109	13.5/12.9 ³¹⁾
MTH 2-4/3	0.55	365	163	202	141	109	13.6/13 ³¹⁾
MTH 2-4/4	0.75	405	163	242	141	109	16.5/13.4 ³¹⁾
MTH 2-5/1	0.55	383	181	202	141	109	13.7/13.1 ³¹⁾
MTH 2-5/2	0.55	383	181	202	141	109	13.9/13.3 ³¹⁾
MTH 2-5/3	0.55	383	181	202	141	109	14/13.4 ³¹⁾
MTH 2-5/4	0.75	423	181	242	141	109	17/13.9 ³¹⁾
MTH 2-5/5	0.75	423	181	242	141	109	17.1/14 ³¹⁾
MTH 2-6/1	0.55	401	199	202	141	109	13.9/13.3 ³¹⁾
MTH 2-6/2	0.55	401	199	202	141	109	14.2/13.6 ³¹⁾
MTH 2-6/3	0.55	401	199	202	141	109	14.3/13.7 ³¹⁾
MTH 2-6/4	0.75	441	199	242	141	109	17.3/14.2 ³¹⁾
MTH 2-6/5	0.75	441	199	242	141	109	17.5/14.4 ³¹⁾
MTH 2-6/6	1.1	461	199	262	141	109	15.5/15.2 ³¹⁾
MTH 2-7/1	0.55	419	217	202	141	109	14.2/13.6 ³¹⁾
MTH 2-7/2	0.55	419	217	202	141	109	14.4/13.8 ³¹⁾
MTH 2-7/3	0.55	419	217	202	141	109	14.7/14.1 ³¹⁾
MTH 2-7/4	0.75	459	217	242	141	109	17.7/14.6 ³¹⁾
MTH 2-7/5	0.75	459	217	242	141	109	17.8/14.7 ³¹⁾
MTH 2-7/6	1.1	479	217	262	141	109	16/15.6 ³¹⁾
MTH 2-7/7	1.1	479	217	262	141	109	16.1/15.7 ³¹⁾
MTH 2-8/1	0.55	437	235	202	141	109	14.4/13.8 ³¹⁾
MTH 2-8/2	0.55	437	235	202	141	109	14.7/14.1 ³¹⁾
MTH 2-8/3	0.55	437	235	202	141	109	14.9/14.3 ³¹⁾
MTH 2-8/4	0.75	477	235	242	141	109	17.9/14.8 ³¹⁾
MTH 2-8/5	0.75	477	235	242	141	109	18.1/15.1 ³¹⁾
MTH 2-8/6	1.1	497	235	262	141	109	16.3/15.9 ³¹⁾

Pump type	Motor P2 [kW]	Dimensions [mm]					Weight [kg]
		A	B	C	AC	AD	
MTH 2-8/7	1.1	497	235	262	141	109	16.5/16.1 ³¹⁾
MTH 2-8/8	1.1	497	235	262	141	109	16.6/16.2 ³¹⁾
MTH 2-9/1	0.55	455	253	202	141	109	14.6/14 ³¹⁾
MTH 2-9/2	0.55	455	253	202	141	109	14.9/14.3 ³¹⁾
MTH 2-9/3	0.55	455	253	202	141	109	15.1/14.5 ³¹⁾
MTH 2-9/4	0.75	495	253	242	141	109	18.1/15 ³¹⁾
MTH 2-9/5	0.75	495	253	242	141	109	18.4/15.3 ³¹⁾
MTH 2-9/6	1.1	515	253	262	141	109	16.5/16.2 ³¹⁾
MTH 2-9/7	1.1	515	253	262	141	109	16.8/16.4 ³¹⁾
MTH 2-9/8	1.1	515	253	262	141	109	16.9/16.6 ³¹⁾
MTH 2-10/1	0.55	473	271	202	141	109	14.9/14.3 ³¹⁾
MTH 2-10/2	0.55	473	271	202	141	109	15.1/14.5 ³¹⁾
MTH 2-10/3	0.55	473	271	202	141	109	15.3/14.7 ³¹⁾
MTH 2-10/4	0.75	513	271	242	141	109	18.4/15.3 ³¹⁾
MTH 2-10/5	0.75	513	271	242	141	109	18.6/15.5 ³¹⁾
MTH 2-10/6	1.1	533	271	262	141	109	16.8/16.4 ³¹⁾
MTH 2-10/7	1.1	533	271	262	141	109	17/16.6 ³¹⁾
MTH 2-10/8	1.1	533	271	262	141	109	17.2/16.9 ³¹⁾
MTH 2-11/1	0.55	491	289	202	141	109	15.1/14.5 ³¹⁾
MTH 2-11/2	0.55	491	289	202	141	109	15.3/14.7 ³¹⁾
MTH 2-11/3	0.55	491	289	202	141	109	15.6/15 ³¹⁾
MTH 2-11/4	0.75	531	289	242	141	109	18.6/15.5 ³¹⁾
MTH 2-11/5	0.75	531	289	242	141	109	18.8/15.7 ³¹⁾
MTH 2-11/6	1.1	551	289	262	141	109	17/16.6 ³¹⁾
MTH 2-11/7	1.1	551	289	262	141	109	17.2/16.9 ³¹⁾
MTH 2-11/8	1.1	551	289	262	141	109	17.5/17.1 ³¹⁾

³¹⁾Applies to pumps fitted with 200 V motors.

MTH 4, 60 Hz

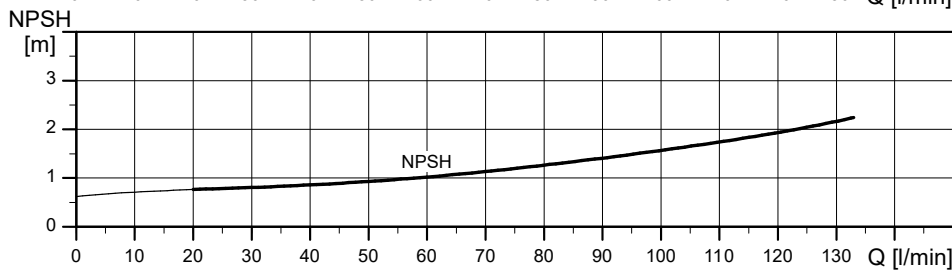
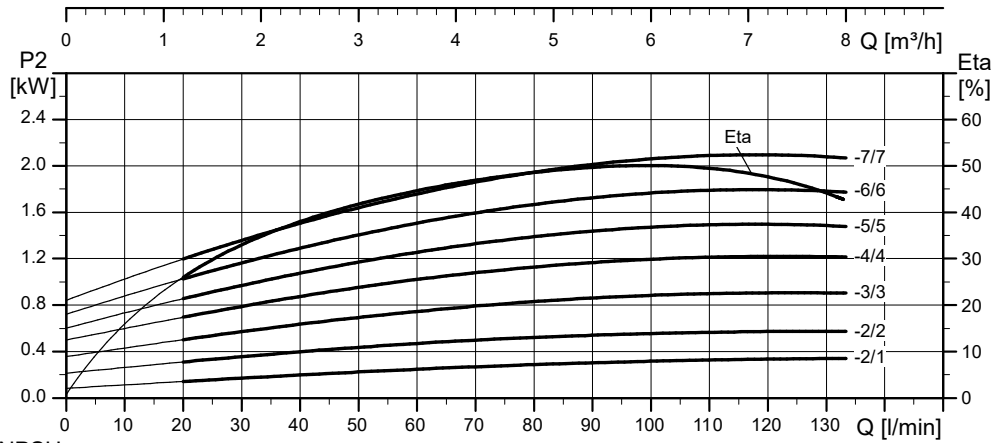
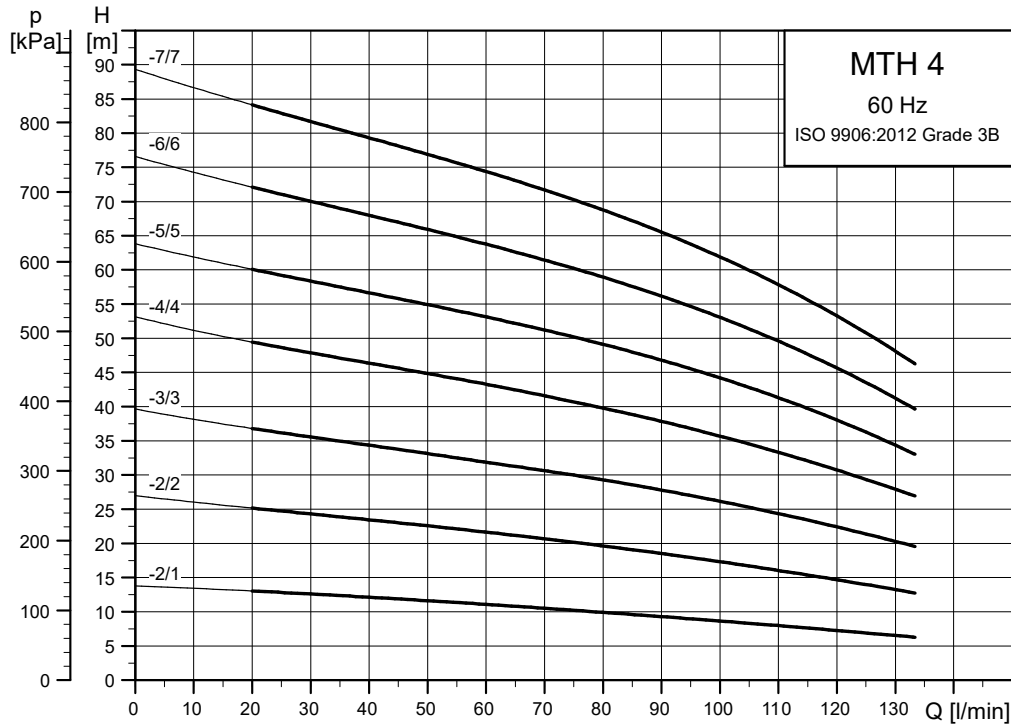

TN0027827

Dimensional sketches

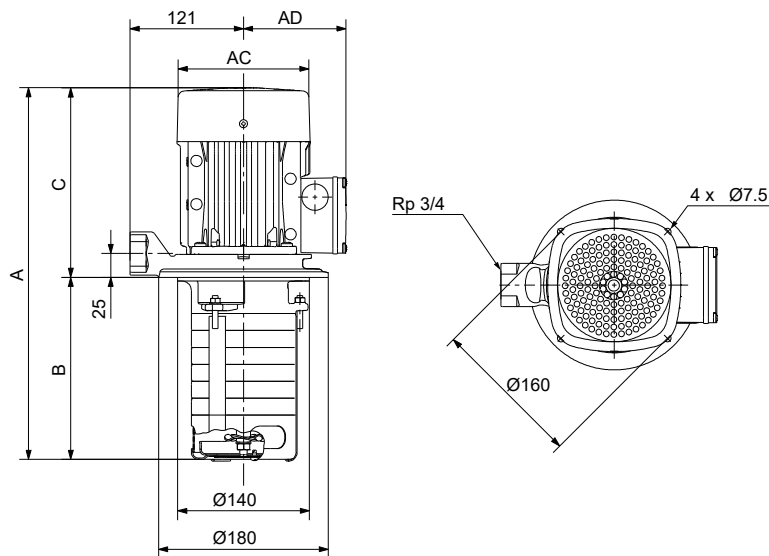

TM067672

Dimensions and weights

Pump type	Motor P2 [kW]	Dimensions [mm]					Weight [kg]
		A	B	C	AC	AD	
MTH 4-2/1	0.55	347	145	202	141	109	13.2/12.6 ³²⁾
MTH 4-2/2	0.55	347	145	202	141	109	13.3/12.7 ³²⁾
MTH 4-3/1	0.55	374	172	202	141	109	13.3/12.7 ³²⁾
MTH 4-3/2	0.55	374	172	202	141	109	13.4/12.8 ³²⁾
MTH 4-3/3	0.75	414	172	242	141	109	16.3/13.3 ³²⁾
MTH 4-4/1	0.55	401	199	202	141	109	13.6/13.3 ³²⁾
MTH 4-4/2	0.55	401	199	202	141	109	13.7/13.1 ³²⁾
MTH 4-4/3	0.75	441	199	242	141	109	16.7/13.6 ³²⁾
MTH 4-4/4	1.1	461	199	262	141	109	14.7/14.3 ³²⁾
MTH 4-5/1	0.55	428	226	202	141	109	13.7/13.1 ³²⁾
MTH 4-5/2	0.55	428	226	202	141	109	13.9/13.3 ³²⁾
MTH 4-5/3	0.75	468	226	242	141	109	16.8/13.7 ³²⁾
MTH 4-5/4	1.1	488	226	262	141	109	14.9/14.6 ³²⁾
MTH 4-5/5	1.5	538/578 ³²⁾	226	312/352 ³²⁾	178	110	26.2/28.7 ³²⁾
MTH 4-6/1	0.55	455	253	202	141	109	13.9/13.3 ³²⁾
MTH 4-6/2	0.55	455	253	202	141	109	14/13.4 ³²⁾
MTH 4-6/3	0.75	495	253	242	141	109	17/13.9 ³²⁾
MTH 4-6/4	1.1	515	253	262	141	109	15.1/14.7 ³²⁾
MTH 4-6/5	1.5	565/605 ³²⁾	253	312/352 ³²⁾	178	110	26.4/28.9 ³²⁾
MTH 4-6/6	2.2	605	253	352	178	110	30.6/29.3 ³²⁾
MTH 4-7/1	0.55	482	280	202	141	109	14.1/13.5 ³²⁾
MTH 4-7/2	0.55	482	280	202	141	109	14.2/13.6 ³²⁾
MTH 4-7/3	0.75	522	280	242	141	109	17.1/14 ³²⁾
MTH 4-7/4	1.1	542	280	262	141	109	15.2/14.9 ³²⁾
MTH 4-7/5	1.5	592/632 ³²⁾	280	312/352 ³²⁾	178	110	26.6/29 ³²⁾
MTH 4-7/6	2.2	632	280	352	178	110	30.8/29.5 ³²⁾
MTH 4-7/7	2.2	632	280	352	178	110	30.9/29.6 ³²⁾
MTH 4-8/1	0.55	509	307	202	141	109	14.2/13.6 ³²⁾
MTH 4-8/2	0.55	509	307	202	141	109	14.3/13.7 ³²⁾
MTH 4-8/3	0.75	549	307	242	141	109	17.3/14.2 ³²⁾
MTH 4-8/4	1.1	569	307	262	141	109	15.4/15 ³²⁾

Pump type	Motor P2 [kW]	Dimensions [mm]					Weight [kg]
		A	B	C	AC	AD	
MTH 4-8/5	1.5	619/659 ³²⁾	307	312/352 ³²⁾	178	110	26.7/29.2 ³²⁾
MTH 4-8/6	2.2	659	307	352	178	110	31/29.7 ³²⁾
MTH 4-8/7	2.2	659	307	352	178	110	31.1/29.8 ³²⁾
MTH 4-9/1	0.55	536	334	202	141	109	14.5/13.9 ³²⁾
MTH 4-9/2	0.55	536	334	202	141	109	14.7/14.1 ³²⁾
MTH 4-9/3	0.75	576	334	242	141	109	17.6/14.5 ³²⁾
MTH 4-9/4	1.1	596	334	262	141	109	15.7/15.4 ³²⁾
MTH 4-9/5	1.5	646/686 ³²⁾	334	312/352 ³²⁾	178	110	27/29.5 ³²⁾
MTH 4-9/6	2.2	686	334	352	178	110	31.3/30 ³²⁾
MTH 4-9/7	2.2	686	334	352	178	110	31.4/30.1 ³²⁾

³²⁾ Applies to pumps fitted with 200 V motors.

MTH 8, 60 Hz

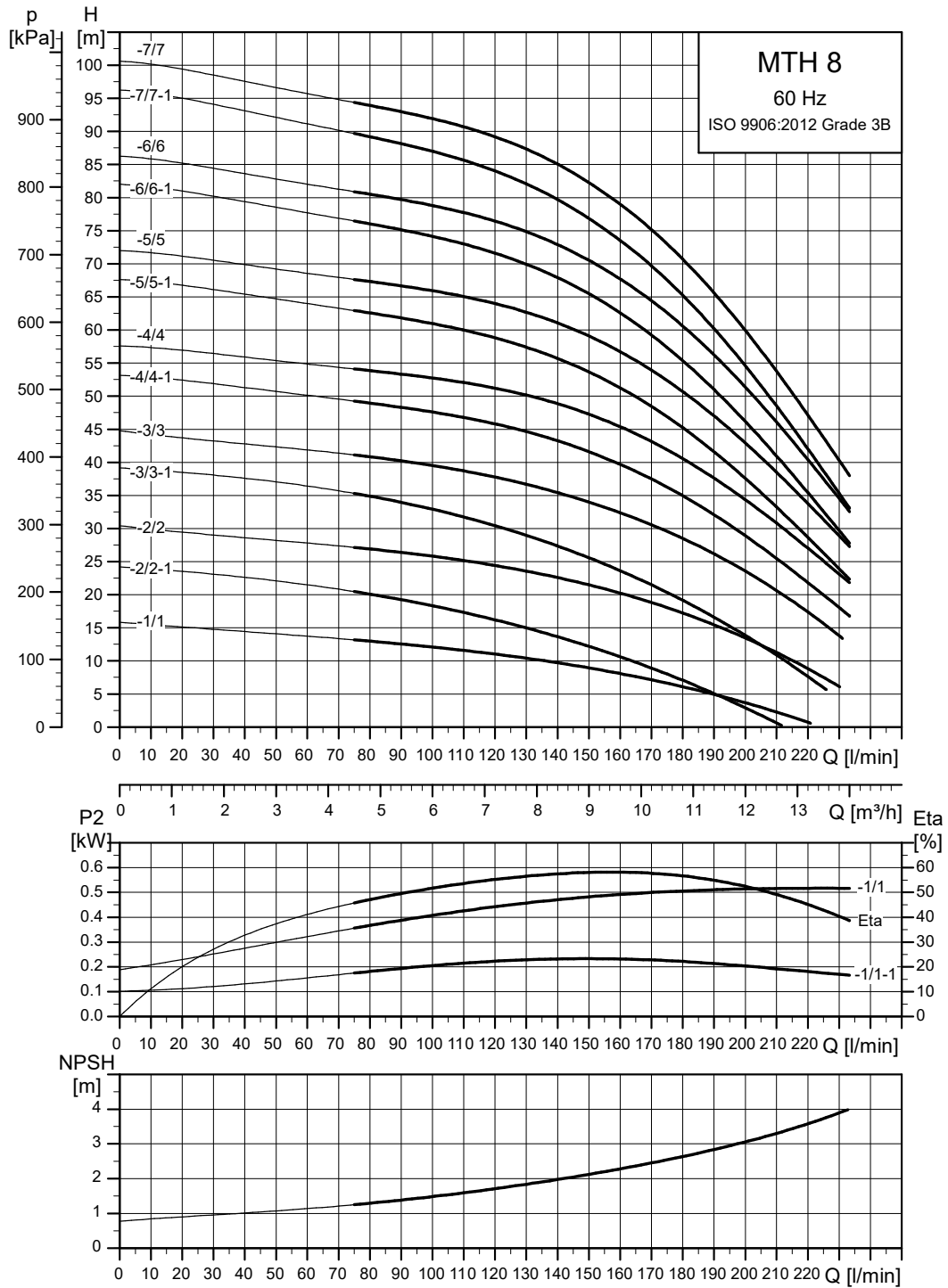

TM062362

Dimensional sketches

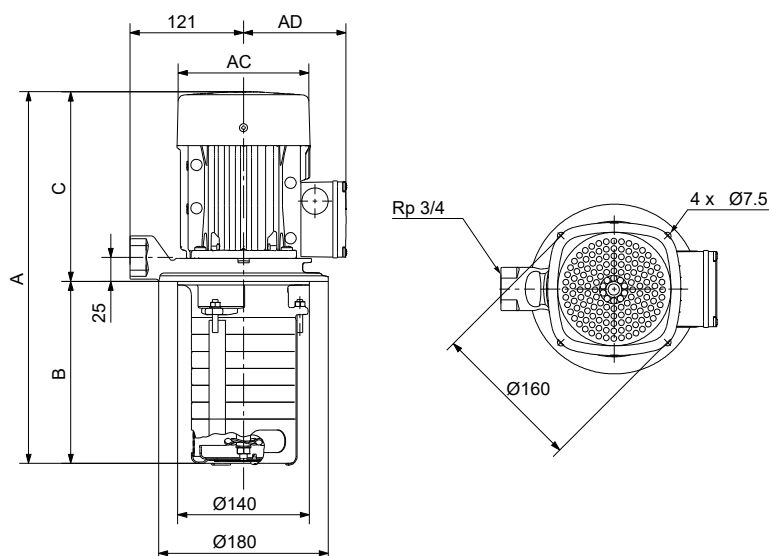

TM067672

Dimensions and weights

Pump type	Motor P2 [kW]	Dimensions [mm]					Weight [kg]
		A	B	C	AC	AD	
MTH 8-1/1	0.55	347	145	202	141	109	12.5/11.9 ³³⁾
MTH 8-2/1	0.55	374	172	202	141	109	12.7/12.1 ³³⁾
MTH 8-2/2-1	1.1	434	172	262	141	109	13.5/13.2 ³³⁾
MTH 8-2/2	1.1	434	172	262	141	109	13.6/13.3 ³³⁾
MTH 8-3/1	0.55	401	199	202	141	109	12.9/12.3 ³³⁾
MTH 8-3/2-1	1.1	461	199	262	141	109	13.7/13.4 ³³⁾
MTH 8-3/2	1.1	461	199	262	141	109	13.8/13.5 ³³⁾
MTH 8-3/3-1	1.5	511/551 ³³⁾	199	312/352 ³³⁾	178	110	25.2/27.7 ³³⁾
MTH 8-3/3	2.2	551	199	352	178	110	29.3/28 ³³⁾
MTH 8-4/1	0.55	428	226	202	141	109	13/12.4 ³³⁾
MTH 8-4/2-1	1.1	488	226	262	141	109	13.9/13.5 ³³⁾
MTH 8-4/2	1.1	488	226	262	141	109	14/13.6 ³³⁾
MTH 8-4/3-1	1.5	538/578 ³³⁾	226	312/352 ³³⁾	178	110	25.4/27.8 ³³⁾
MTH 8-4/3	2.2	578	226	352	178	110	29.5/28.2 ³³⁾
MTH 8-4/4-1	2.2	578	226	352	178	110	29.7/28.4 ³³⁾
MTH 8-4/4	2.2	578	226	352	178	110	29.7/28.4 ³³⁾
MTH 8-5/1	0.55	455	253	202	141	109	13.2/12.6 ³³⁾
MTH 8-5/2-1	1.1	515	253	262	141	109	14.1/13.7 ³³⁾
MTH 8-5/2	1.1	515	253	262	141	109	14.2/13.8 ³³⁾
MTH 8-5/3-1	1.5	565/605 ³³⁾	253	312/352 ³³⁾	178	110	25.5/28 ³³⁾
MTH 8-5/3	2.2	605	253	352	178	110	29.7/28.4 ³³⁾
MTH 8-5/4-1	2.2	605	253	352	178	110	29.9/28.6 ³³⁾
MTH 8-5/4	2.2	605	253	352	178	110	29.9/28.6 ³³⁾
MTH 8-5/5-1	3	623	253	370	198	120	33.8/36.7 ³³⁾
MTH 8-5/5	3	623	253	370	198	120	33.8/36.7 ³³⁾
MTH 8-6/1	0.55	482	280	202	141	109	13.3/12.7 ³³⁾
MTH 8-6/2-1	1.1	542	280	262	141	109	14.2/13.9 ³³⁾
MTH 8-6/2	1.1	542	280	262	141	109	14.3/14 ³³⁾
MTH 8-6/3-1	1.5	592/632 ³³⁾	280	312/352 ³³⁾	178	110	25.7/28.2 ³³⁾
MTH 8-6/3	2.2	632	280	352	178	110	29.8/28.5 ³³⁾
MTH 8-6/4-1	2.2	632	280	352	178	110	30/28.7 ³³⁾

Pump type	Motor P2 [kW]	Dimensions [mm]					Weight [kg]
		A	B	C	AC	AD	
MTH 8-6/4	2.2	632	280	352	178	110	30.1/28.8 ³³⁾
MTH 8-6/5-1	3	650	280	370	198	120	34/36.8 ³³⁾
MTH 8-6/5	3	650	280	370	198	120	34/36.9 ³³⁾
MTH 8-6/6-1	3	650	280	370	198	120	34.2/37.1 ³³⁾
MTH 8-6/6	4	687	280	407	220	134	36.8/37.1 ³³⁾
MTH 8-7/1	0.55	509	307	202	141	109	13.5/12.9 ³³⁾
MTH 8-7/2-1	1.1	569	307	262	141	109	14.4/14 ³³⁾
MTH 8-7/2	1.1	569	307	262	141	109	14.5/14.1 ³³⁾
MTH 8-7/3-1	1.5	619/659 ³³⁾	307	312/352 ³³⁾	178	110	25.9/28.3 ³³⁾
MTH 8-7/3	2.2	659	307	352	178	110	30/28.7 ³³⁾
MTH 8-7/4-1	2.2	659	307	352	178	110	30.2/28.9 ³³⁾
MTH 8-7/4	2.2	659	307	352	178	110	30.2/28.9 ³³⁾
MTH 8-7/5-1	3	677	307	370	198	120	34.1/37 ³³⁾
MTH 8-7/5	3	677	307	370	198	120	34.2/37 ³³⁾
MTH 8-7/6-1	3	677	307	370	198	120	34.3/37.2 ³³⁾
MTH 8-7/6	4	714	307	407	220	134	36.9/37.2 ³³⁾
MTH 8-7/7-1	4	714	307	407	220	134	37.1/37.4 ³³⁾
MTH 8-7/7	4	714	307	407	220	134	37.2/37.5 ³³⁾
MTH 8-8/1	0.55	536	334	202	141	109	13.8/13.2 ³³⁾
MTH 8-8/2-1	1.1	596	334	262	141	109	14.7/14.3 ³³⁾
MTH 8-8/2	1.1	596	334	262	141	109	14.8/14.4 ³³⁾
MTH 8-8/3-1	1.5	646/686 ³³⁾	334	312/352 ³³⁾	178	110	26.2/28.6 ³³⁾
MTH 8-8/3	2.2	686	334	352	178	110	30.3/29 ³³⁾
MTH 8-8/4-1	2.2	686	334	352	178	110	30.5/29.2 ³³⁾
MTH 8-8/4	2.2	686	334	352	178	110	30.5/29.2 ³³⁾
MTH 8-8/5-1	3	704	334	370	198	120	34.4/37.3 ³³⁾
MTH 8-8/5	3	704	334	370	198	120	34.5/37.3 ³³⁾
MTH 8-8/6-1	3	704	334	370	198	120	34.7/37.5 ³³⁾
MTH 8-8/6	4	741	334	407	220	134	37.3/37.6 ³³⁾
MTH 8-8/7-1	4	741	334	407	220	134	37.5/37.8 ³³⁾
MTH 8-8/7	4	741	334	407	220	134	37.5/37.8 ³³⁾

³³⁾ Applies to pumps fitted with 200 V motors.

MTH 10, 60 Hz

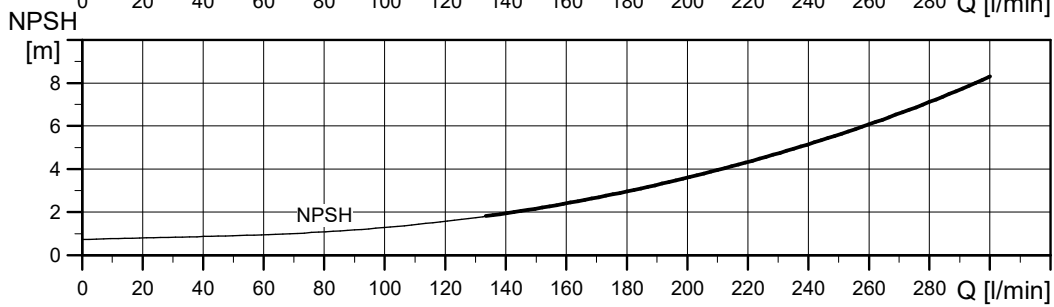
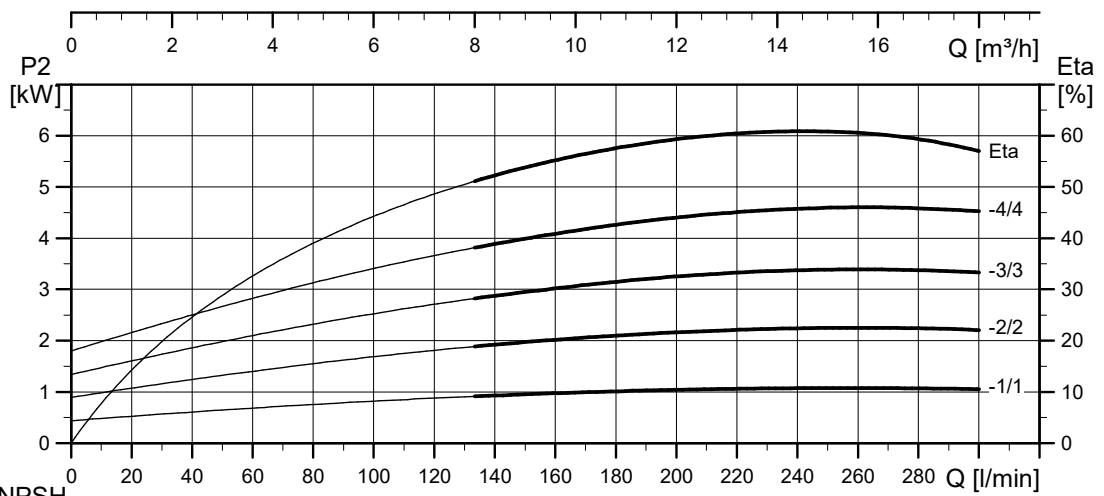
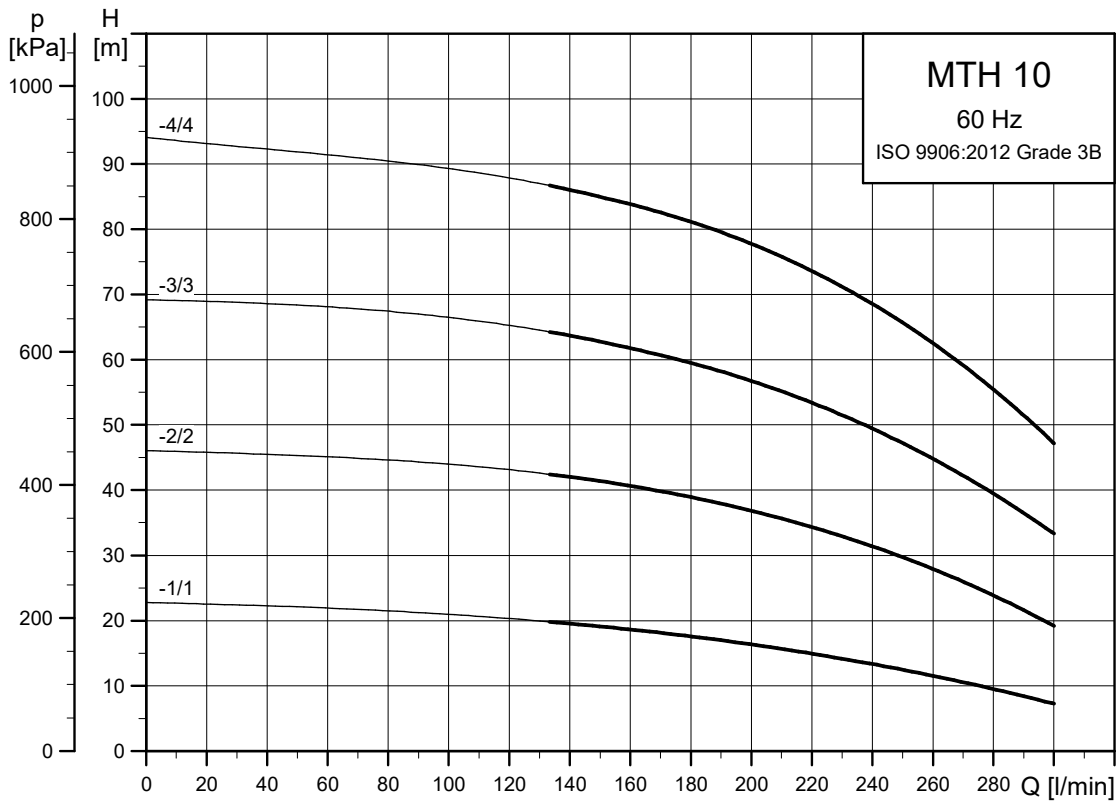

TM068920

Dimensional sketches

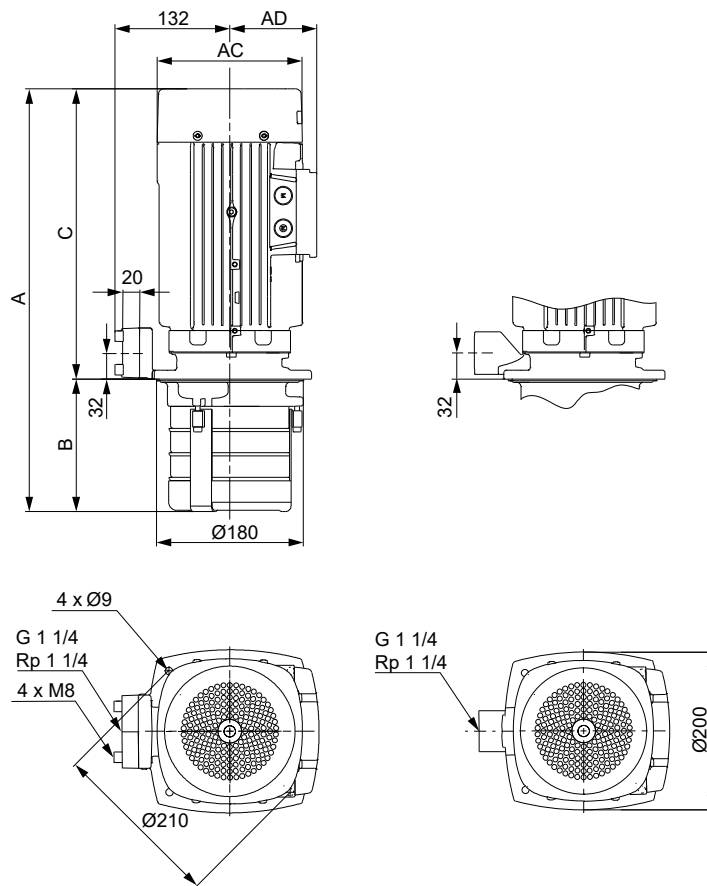

A-version (left), I-version (right).

Dimensions and weights

Pump type	Motor P2 [kW]	MT					Net weight [kg]
		Dimensions [mm]					
		A	B	C	AC	AD	
MTH 10-1/1	1.1	375	105	270	141	109	17.3/17.3 ³⁴⁾
MTH 10-2/1	1.1	405	135	270	141	109	17.8/17.5 ³⁴⁾
MTH 10-2/2	2.2	495	135	360	178	110	31.7/30.4 ³⁴⁾
MTH 10-3/1	1.1	435	165	270	141	109	18.1/17.8 ³⁴⁾
MTH 10-3/2	2.2	525	165	360	178	110	32.2/30.9 ³⁴⁾
MTH 10-3/3	3	542	165	377	198	120	37.4/40.2 ³⁴⁾
MTH 10-4/1	1.1	465	195	270	141	109	17.9/17.6 ³⁴⁾
MTH 10-4/2	2.2	555	195	360	178	110	32/30.7 ³⁴⁾
MTH 10-4/3	3	572	195	377	198	120	37.4/40.2 ³⁴⁾
MTH 10-4/4	4	608	195	413	220	134	40.6/40.9 ³⁴⁾
MTH 10-5/1	1.1	495	225	270	141	109	18.3/17.9 ³⁴⁾
MTH 10-5/2	2.2	585	225	360	178	110	32.3/31.1 ³⁴⁾
MTH 10-5/3	3	602	225	377	198	120	37.7/40.5 ³⁴⁾
MTH 10-5/4	4	638	225	413	220	134	41.1/41.4 ³⁴⁾
MTH 10-6/1	1.1	525	255	270	141	109	18.7/18.3 ³⁴⁾
MTH 10-6/2	2.2	615	255	360	178	110	32.8/31.5 ³⁴⁾
MTH 10-6/3	3	632	255	377	198	120	38.1/41 ³⁴⁾
MTH 10-6/4	4	668	255	413	220	134	41.5/41.8 ³⁴⁾

³⁴⁾Applies to pumps fitted with 200 V motors.

TM069507

MTH 15, 60 Hz

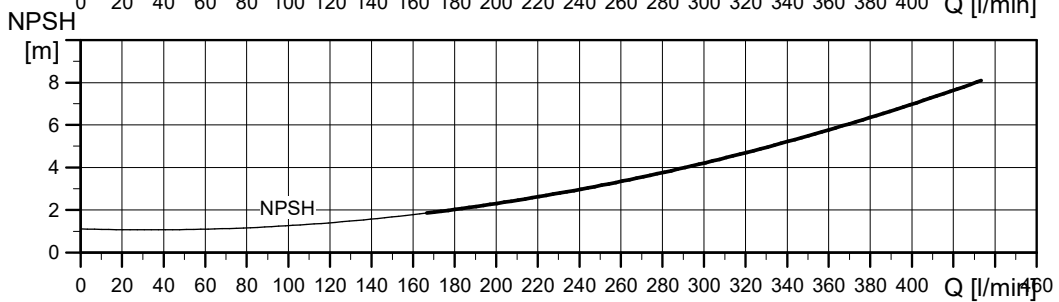
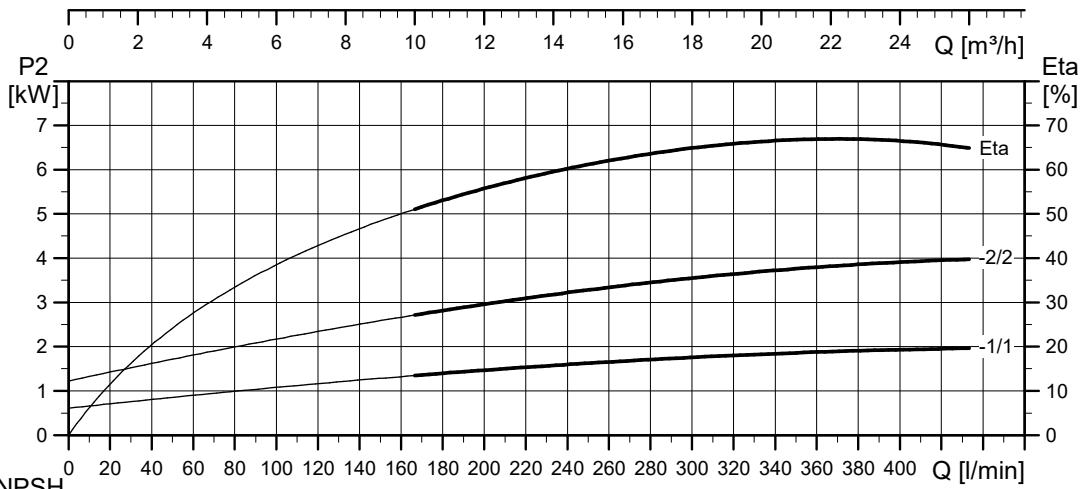
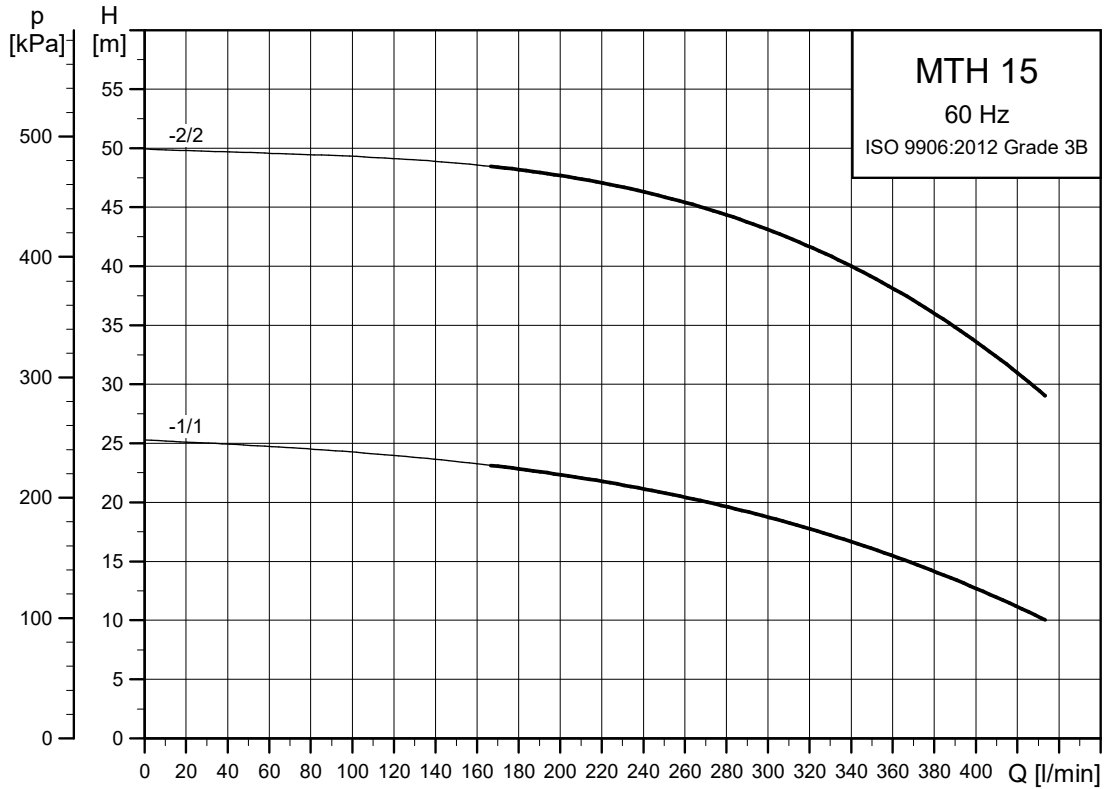

TM068922

Dimensional sketches

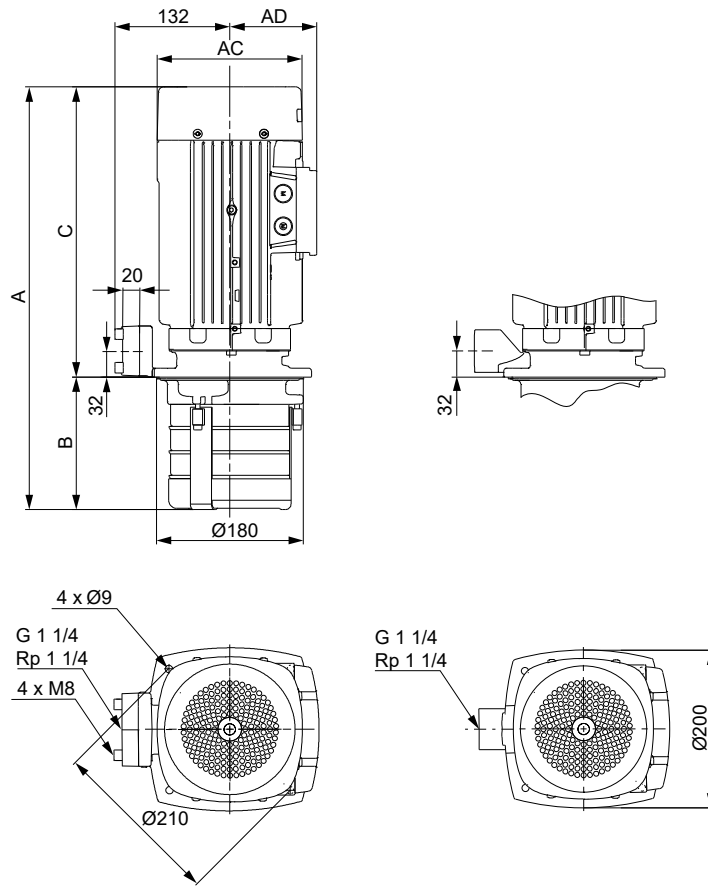

TM069507

A-version (left), I-version (right).

Dimensions and weights

Pump type	Motor P2 [kW]	MT					Net weight [kg]
		Dimensions [mm]					
		A	B	C	AC	AD	
MTH 15-1/1	2.2	465	105	360	178	110	30.4/29.2 ³⁵⁾
MTH 15-2/1	2.2	495	135	360	178	110	31/29.7 ³⁵⁾
MTH 15-2/2	4	548	135	413	220	134	38.7/39 ³⁵⁾
MTH 15-3/1	2.2	525	165	360	178	110	31.3/30 ³⁵⁾
MTH 15-3/2	4	578	165	413	220	134	39.2/39.5 ³⁵⁾
MTH 15-4/1	2.2	555	195	360	178	110	31.1/29.8 ³⁵⁾
MTH 15-4/2	4	608	195	413	220	134	39/39.3 ³⁵⁾
MTH 15-5/1	2.2	585	225	360	178	110	31.5/30.2 ³⁵⁾
MTH 15-5/2	4	638	225	413	220	134	39.4/39.7 ³⁵⁾
MTH 15-6/1	2.2	615	255	360	178	110	31.9/30.6 ³⁵⁾
MTH 15-6/2	4	668	255	413	220	134	39.8/40.1 ³⁵⁾

³⁵⁾Applies to pumps fitted with 200 V motors.

MTA, 50/60 Hz

MTA 30

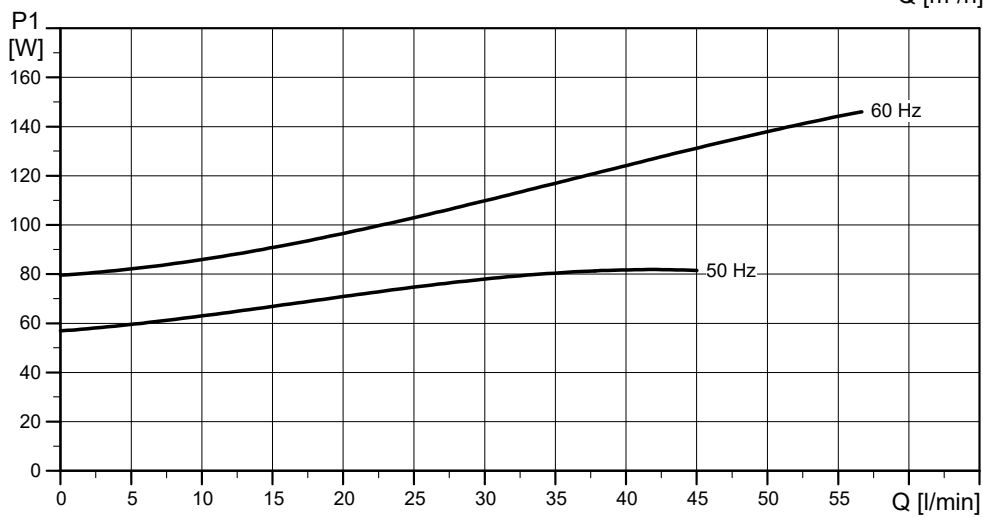
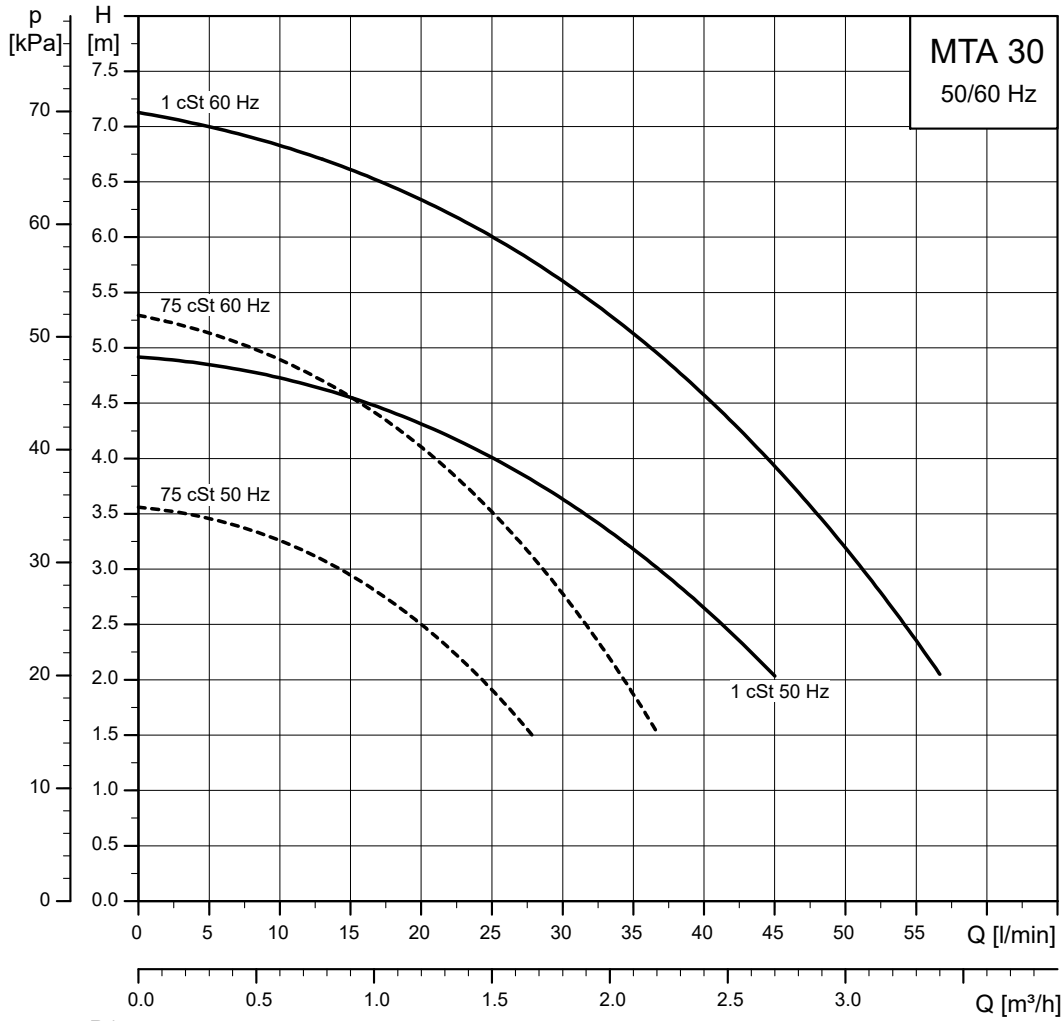

TM050857

Dimensional sketches

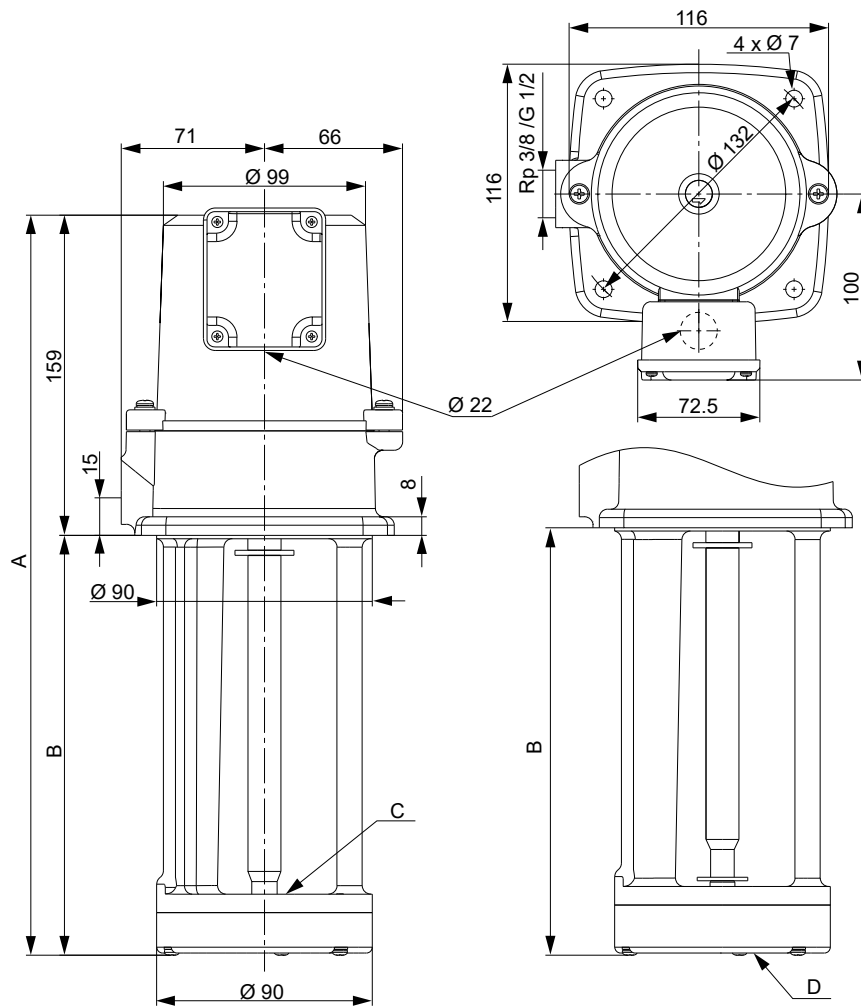

Left: Top inlet (C). Right: Bottom inlet (D).

Dimensions and weights

Pump type	Inlet	A [mm]	B [mm]	Net weight [kg]	Gross weight [kg]	Shipping volume [m ³]
MTA 30-150	Top	309	150	6.7	7.6	0.012
MTA 30-150	Bottom	312	153	6.7	7.7	0.012

Electrical data

Voltage	Frequency [Hz]	P1 [W]	I _{1/1} [A]	I _{max} [A]	I _{start} [A]	Cos φ
3 x 200 Δ V	50	82	0.41	0.47	3.28	0.58
3 x 200-220 Δ V	60	145	0.5	0.58 - 0.58	3.65 - 3.80	0.84 - 0.76
3 x 220-240 Δ / 380-415Y V	50	86	0.33/0.19	0.38/0.22	3.14/1.81	0.68 - 0.63
3 x 220-240 Δ / 380-440Y V	60	142	0.41/0.24 - 0.22	0.47/0.28 - 0.25	3.36/1.97 - 1.80	0.91 - 0.83

TM050879

MTA 60

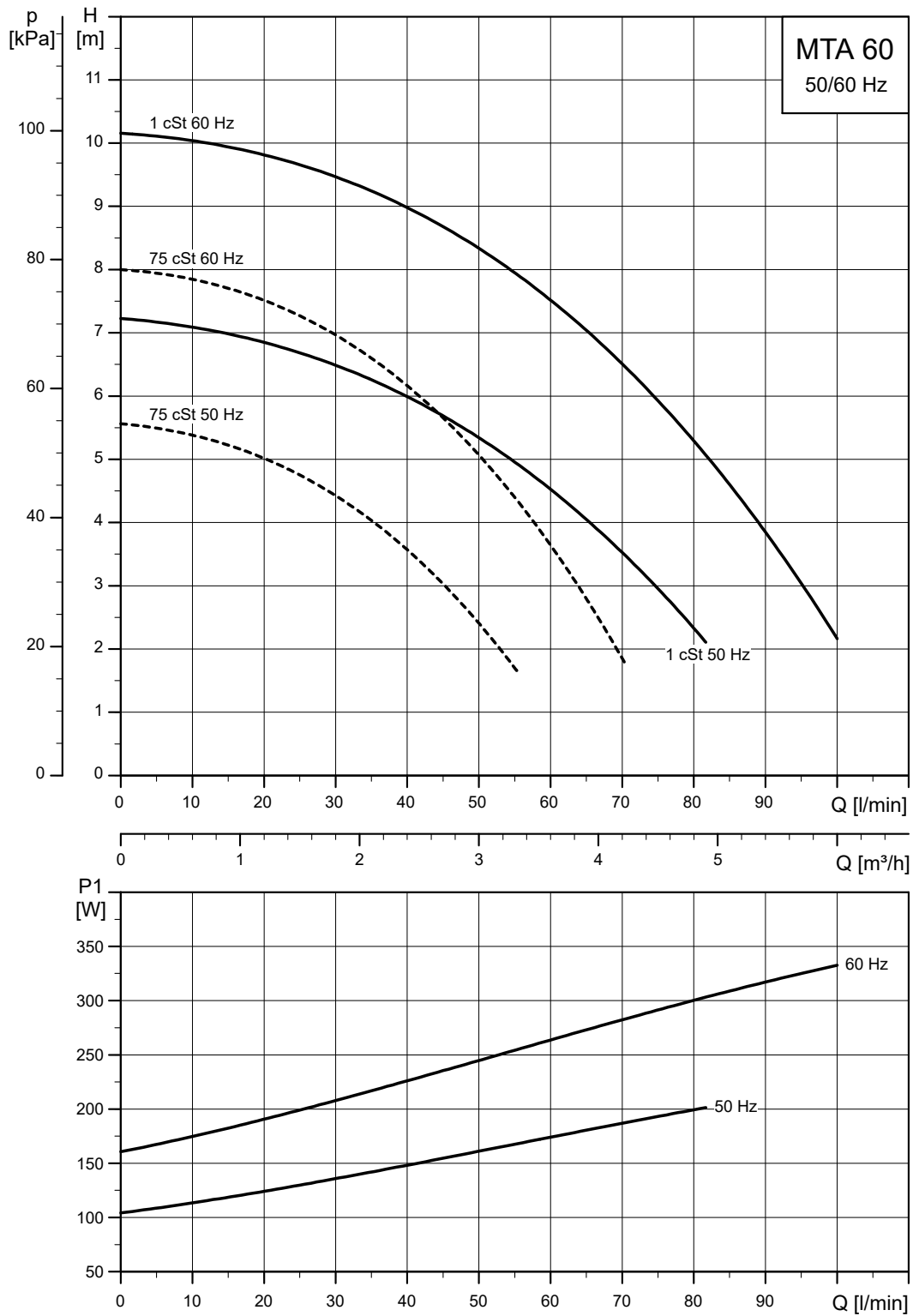

TMC050858

Dimensional sketches

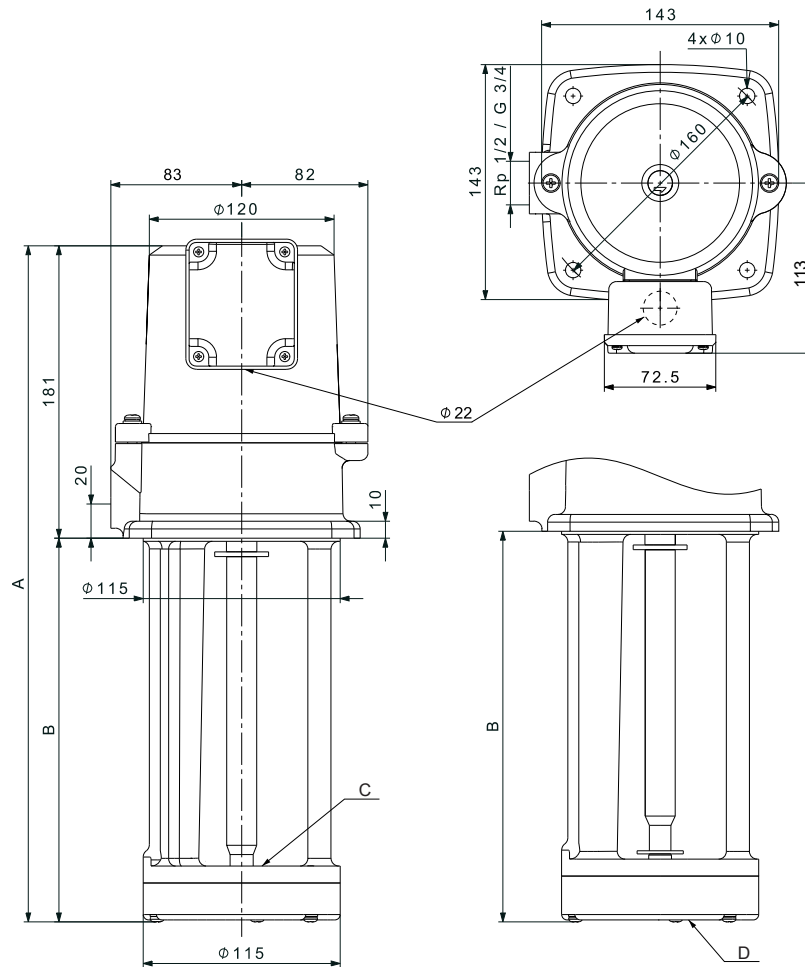

Left: Top inlet (C). Right: Bottom inlet (D).

Dimensions and weights

Pump type	Inlet	A [mm]	B [mm]	Net weight [kg]	Gross weight [kg]	Shipping volume [m ³]
MTA 60-130	Top	306	125	10.6	11.6	0.170
MTA 60-180		356	175	11.1	12.2	0.020
MTA 60-250		426	245	11.8	12.2	0.023
MTA 60-350		526	345	12.9	14.7	0.027
MTA 60-130	Bottom	311.5	130.5	10.9	11.8	0.017
MTA 60-180		361.5	180.5	11.4	12.4	0.020
MTA 60-250		431.5	250.5	12.2	13.5	0.023
MTA 60-350		531.5	350.5	13.2	14.9	0.027

Electrical data

Voltage	Frequency [Hz]	P1 [W]	I _{1/1} [A]	I _{max} [A]	I _{start} [A]	Cos φ
3 x 200 Δ V	50	202	0.78	0.90	5.38	0.75
3 x 200-220 Δ V	60	333	1.18 - 1.09	1.36 - 1.27	6.25 - 6.43	0.81 - 0.80
3 x 220-240 Δ / 380-415Y V	50	200	0.69/0.42	0.79/0.48	5.87/3.57	0.76 - 0.70
3 x 220-240 Δ / 380-440Y V	60	330	0.99/0.63 - 0.57	1.14/0.72 - 0.66	6.44/4.10 - 3.71	0.87 - 0.80

TMD050880

MTA 90

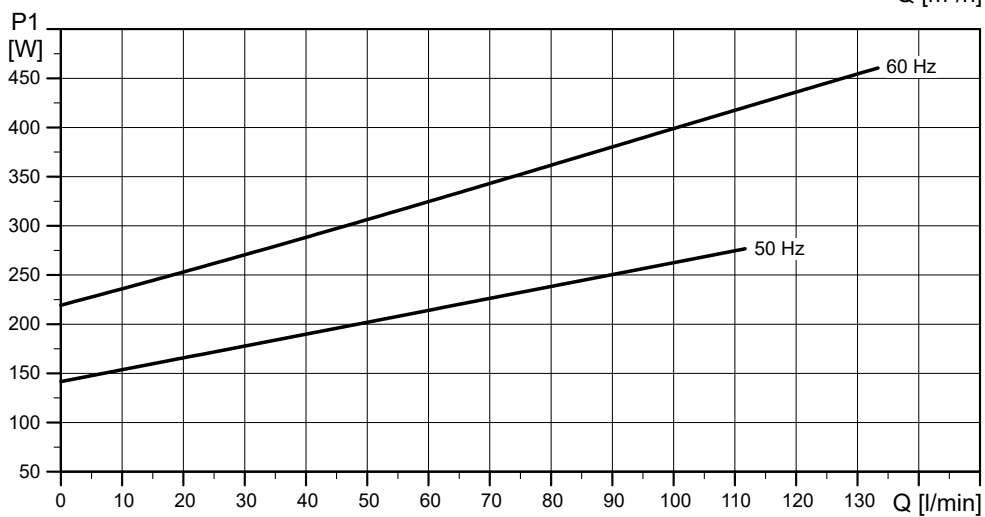
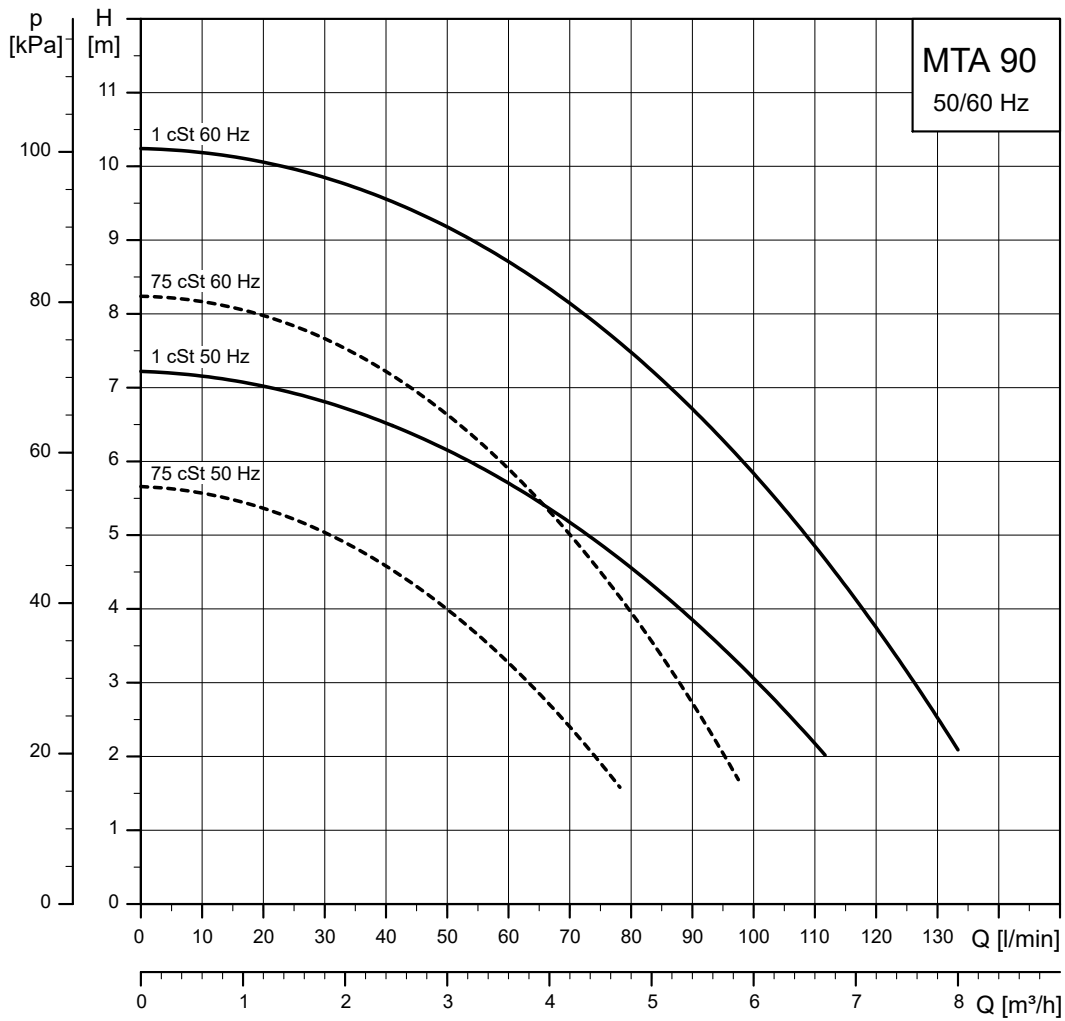

TMD050859

Dimensional sketches

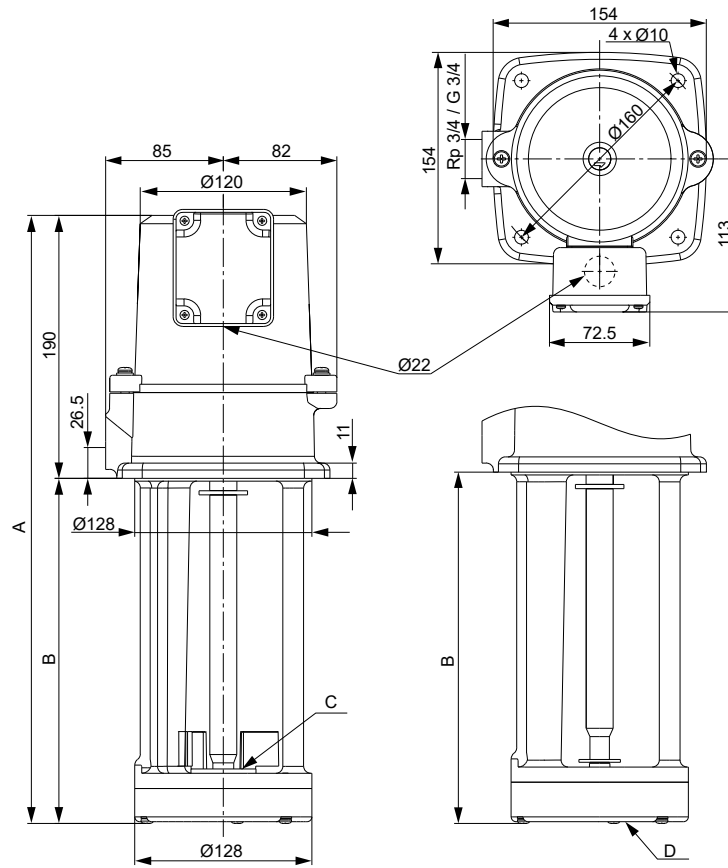

Left: Top inlet (C). Right: Bottom inlet (D).

TM050881

Dimensions and weights

Pump type	Inlet	A [mm]	B [mm]	Net weight [kg]	Gross weight [kg]	Shipping volume [m ³]
MTA 90-130	Top	318	128	12.5	14.2	0.017
MTA 90-180		368	178	13.3	15.1	0.020
MTA 90-250		438	248	14.2	16.2	0.023
MTA 90-350		538	348	15.6	17.9	0.027
MTA 90-130	Bottom	322.5	132.5	12.9	14.3	0.017
MTA 90-180		372.5	182.5	13.6	15.2	0.020
MTA 90-250		442.5	252.5	14.5	16.3	0.023
MTA 90-350		542.5	352.5	15.9	18.0	0.027

Electrical data

Voltage	Frequency [Hz]	P1 [W]	I _{1/1} [A]	I _{max} [A]	I _{start} [A]	Cos φ
3 x 200 Δ V	50	276	1.12	1.29	8.29	0.71
3 x 200-220 Δ V	60	460	1.63 - 1.51	1.87 - 1.74	9.29 - 9.51	0.81 - 0.80
3 x 220-240 Δ / 380-415Y V	50	270	0.97/0.55	1.12/0.63	7.86/4.46	0.73 - 0.67
3 x 220-240 Δ / 380-440Y V	60	440	1.3/0.8 - 0.72	1.5/0.92 - 0.83	8.45/5.20 - 4.68	0.89 - 0.81

MTA 120

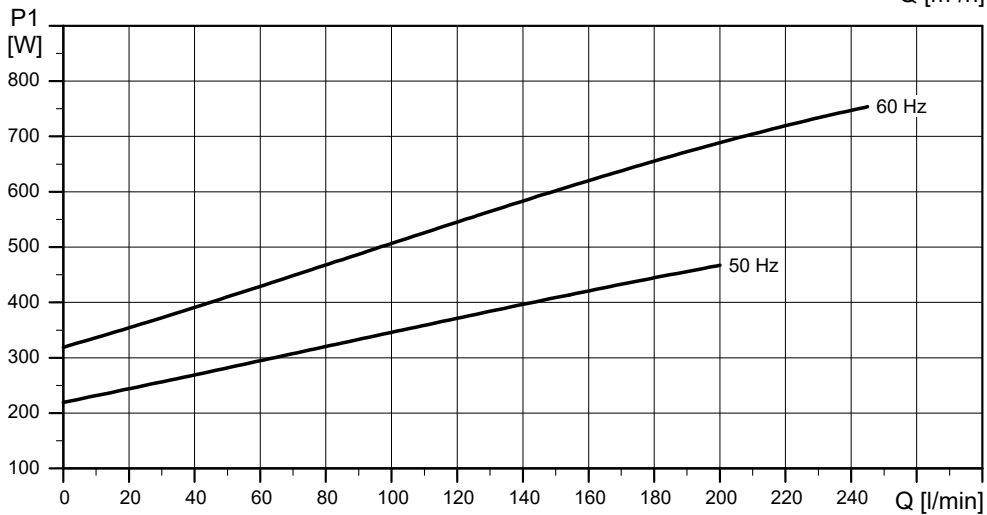
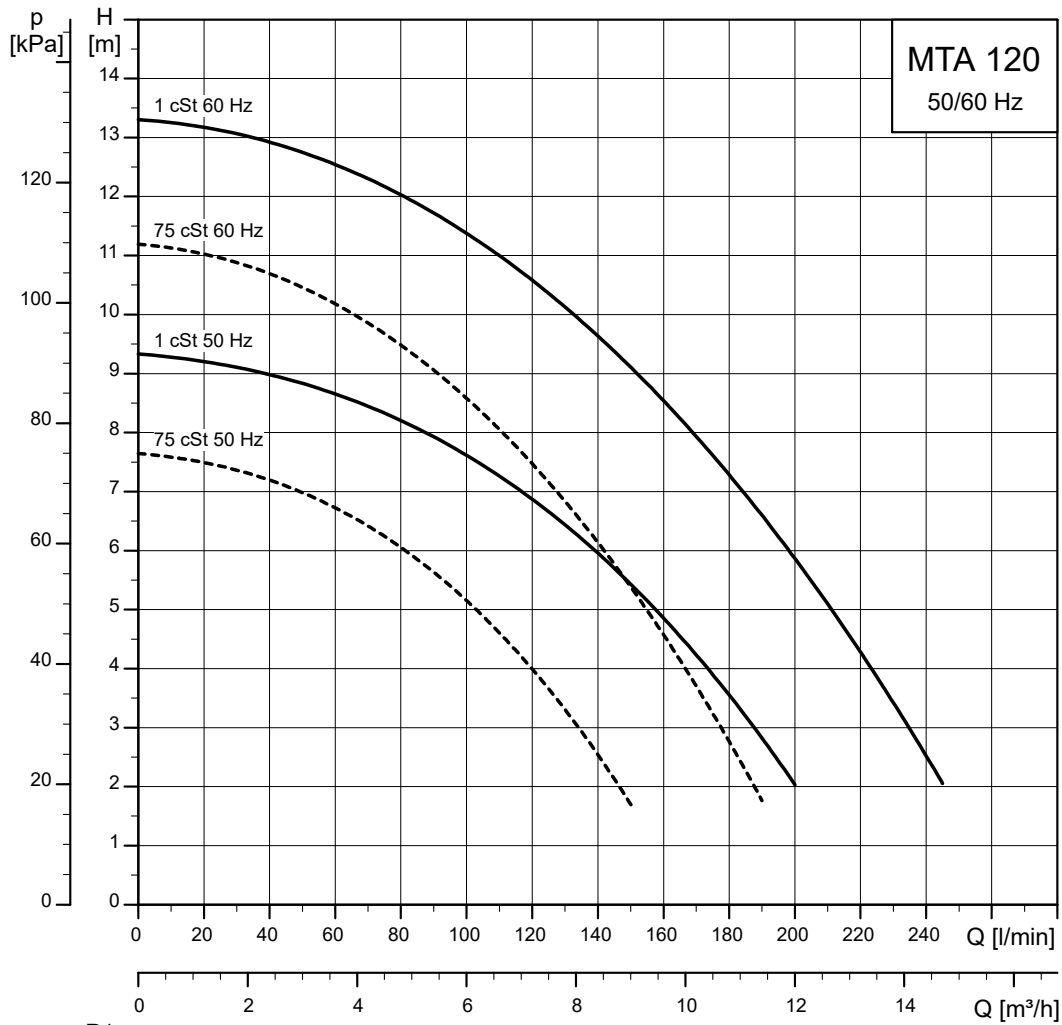

TMD050860

Dimensional sketches

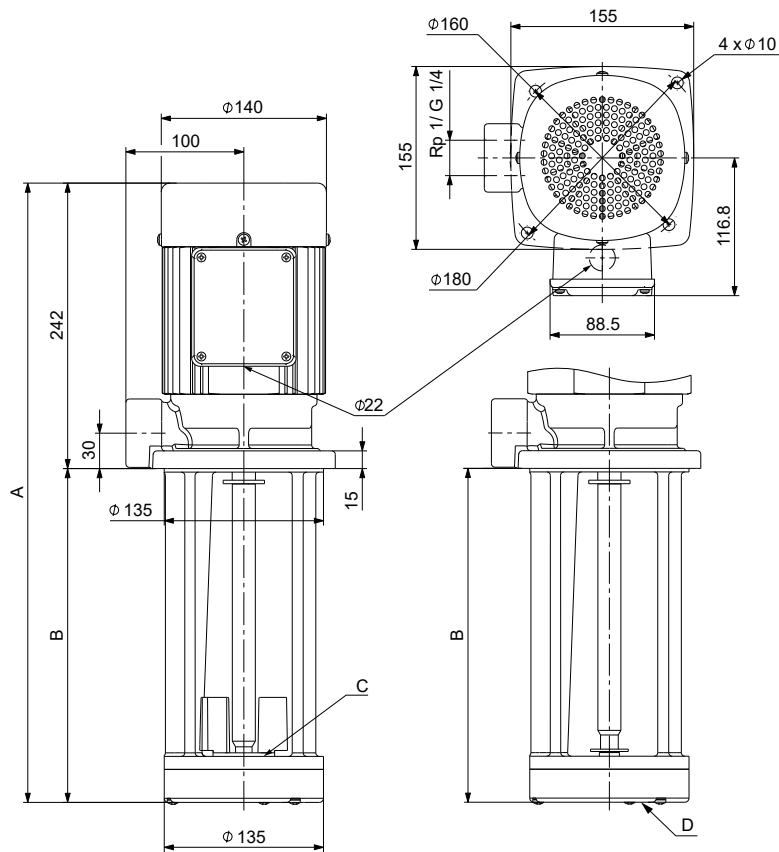

TMC50882

Left: Top inlet (C). Right: Bottom inlet (D).

Dimensions and weights

Pump type	Inlet	A [mm]	B [mm]	Net weight [kg]	Gross weight [kg]	Shipping volume [m ³]
MTA 120-180	Top	422	180	14.6	16.3	0.026
MTA 120-250		492	250	16.4	17.8	0.032
MTA 120-280		522	280	16.7	18.2	0.032
MTA 120-350		592	350	18.8	20.3	0.036
MTA 120-180	Bottom	425	183	15.5	16.9	0.026
MTA 120-250		495	253	16.6	18	0.032
MTA 120-280		525	283	17.3	18.8	0.032
MTA 120-350		595	353	19	20.5	0.036

Electrical data

Voltage	Frequency [Hz]	P1 [W]	I _{1/1} [A]	I _{max} [A]	I _{start} [A]	Cos φ
3 x 200 Δ V	50	468	1.79	2.06	12.2	0.75
3 x 200-220 Δ V	60	755	2.47 - 2.37	2.84 - 2.73	13.8 - 14.2	0.88 - 0.84
3 x 220-240 Δ / 380-415Y V	50	440	1.47/0.87	1.69/1.00	10.0/5.92	0.79 - 0.72
3 x 220-240 Δ / 380-440Y V	60	730	2.1/1.26 - 1.13	2.42/1.45 - 1.30	11.34/6.80 - 6.10	0.91 - 0.84

MTA 200

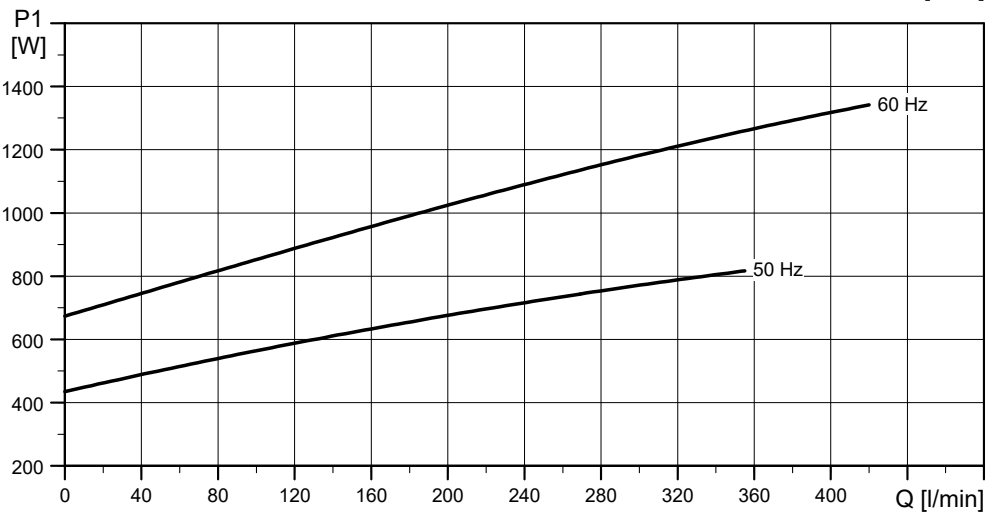
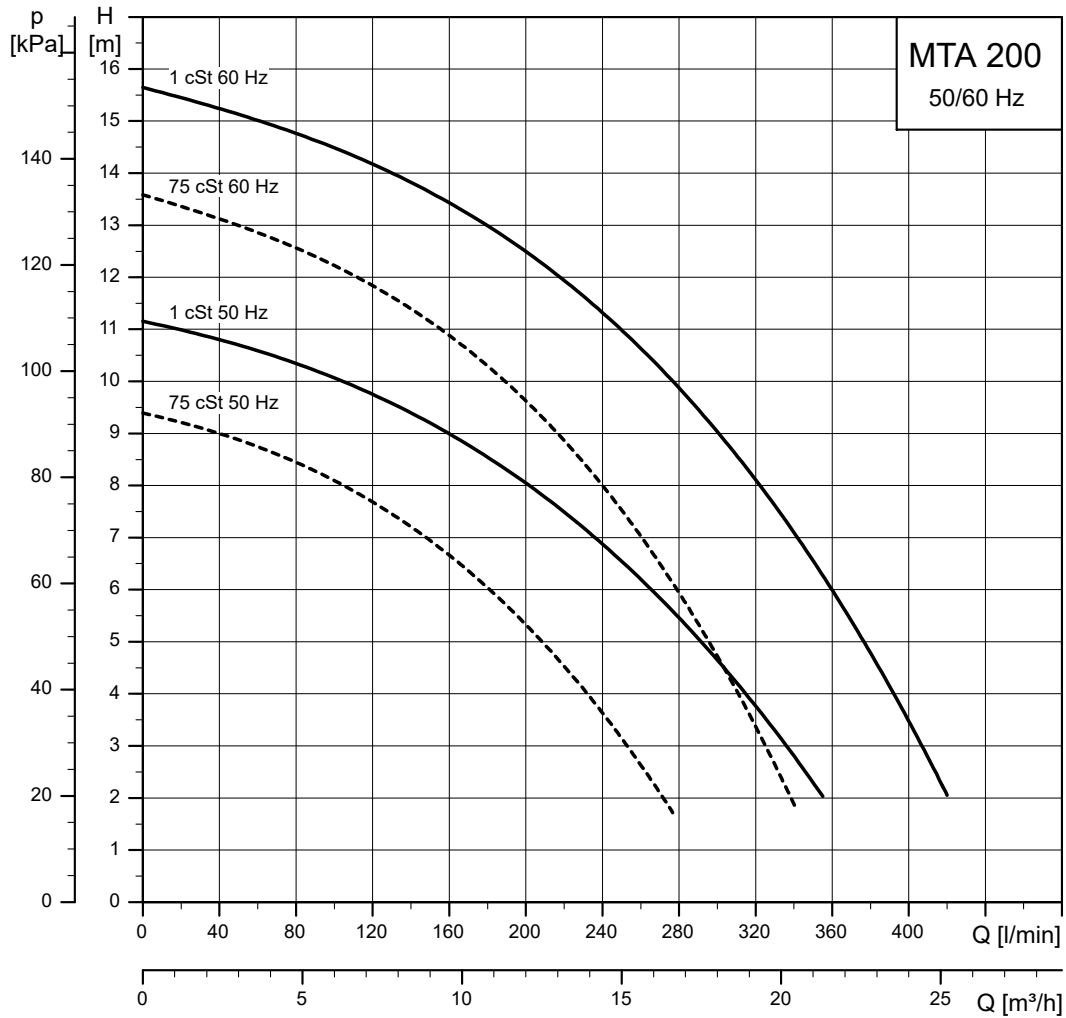

TMD050861

Dimensional sketches

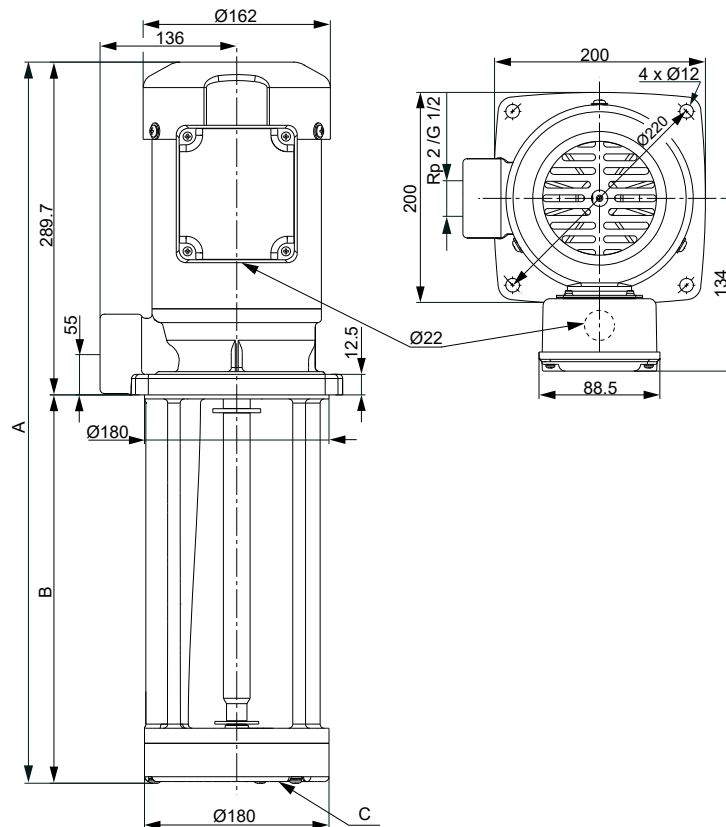

TM050883

C: Bottom inlet.

Dimensions and weights

Pump type	Inlet	A [mm]	B [mm]	Net weight [kg]	Gross weight [kg]	Shipping volume [m ³]
MTA 200-210	Bottom	494.7	210	23.8	26.4	0.06
MTA 200-250		534.7	250	24.3	26.9	0.06
MTA 200-280		564.7	280	24.8	27.4	0.06
MTA 200-350		634.7	350	25.8	28.6	0.067

Electrical data

Voltage	Frequency [Hz]	P1 [W]	I _{1/1} [A]	I _{max} [A]	I _{start} [A]	Cos φ
3 x 200 Δ V	50	815	2.85	3.28	23.9	0.83
3 x 200-220 Δ V	60	1340	4.28 - 4.28	4.92 - 4.92	27.8 - 27.8	0.90 - 0.82
3 x 220-240 Δ / 380-415Y V	50	790	2.78/1.64	3.2/1.89	23.9/14.1	0.75 - 0.68
3 x 220-240 Δ / 380-440Y V	60	1270	3.48/2.11 - 1.96	4.0/2.43 - 2.25	27.5/16.7 - 15.5	0.96 - 0.88

MTA 20H

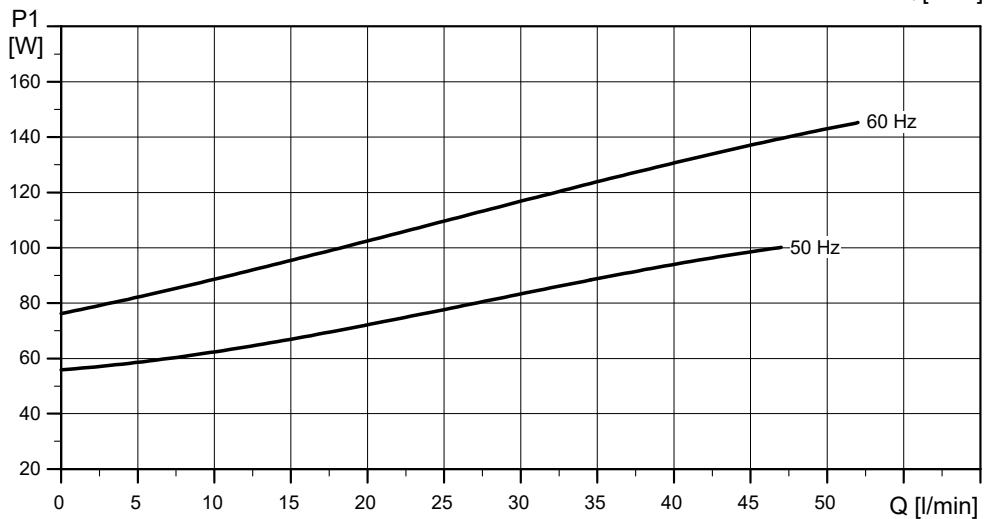
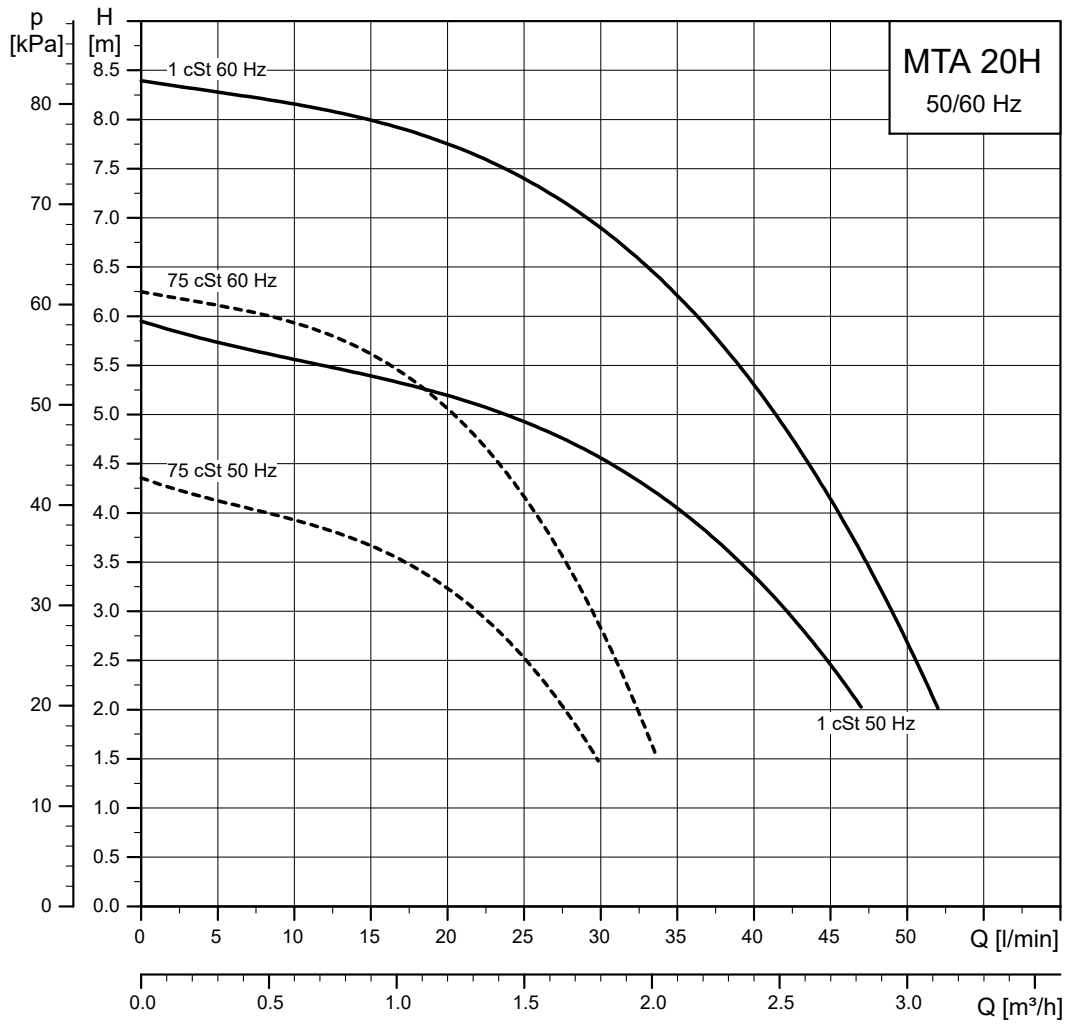

TMD050862

Dimensional sketches

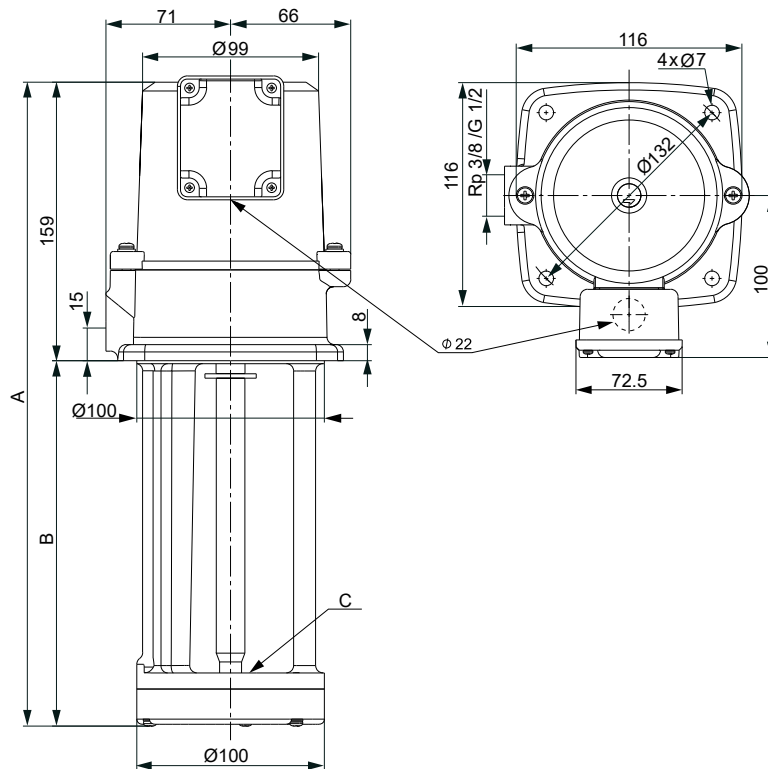

TM050884

C: Top inlet.

Dimensions and weights

Pump type	Inlet	A [mm]	B [mm]	Net weight [kg]	Gross weight [kg]	Shipping volume [m ³]
MTA 20H-150	Top	309	150	6.8	7.7	0.012

Electrical data

Voltage	Frequency [Hz]	P1 [W]	I _{1/1} [A]	I _{max} [A]	I _{start} [A]	Cos φ
3 x 200 Δ V	50	100	0.39	0.45	3.32	0.74
3 x 200-220 Δ V	60	145	0.46 - 0.46	0.53 - 0.53	3.68 - 3.82	0.91 - 0.83
3 x 220-240 Δ / 380-415Y V	50	95	0.37/0.19	0.43/0.22	3.52/1.81	0.67 - 0.62
3 x 220-240 Δ / 380-440Y V	60	140	0.41/0.25 - 0.22	0.47/0.29 - 0.25	3.24/1.98 - 1.74	0.9 - 0.82

MTA 40H

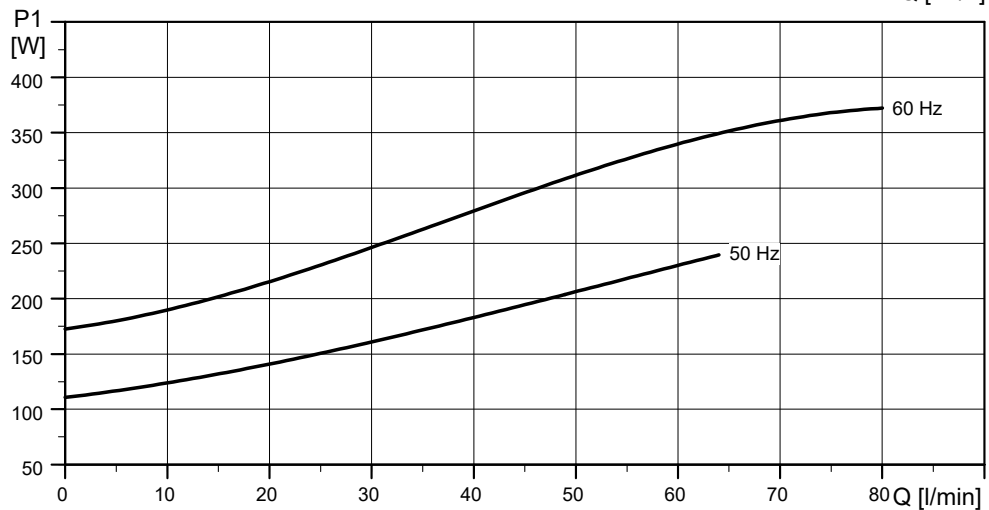
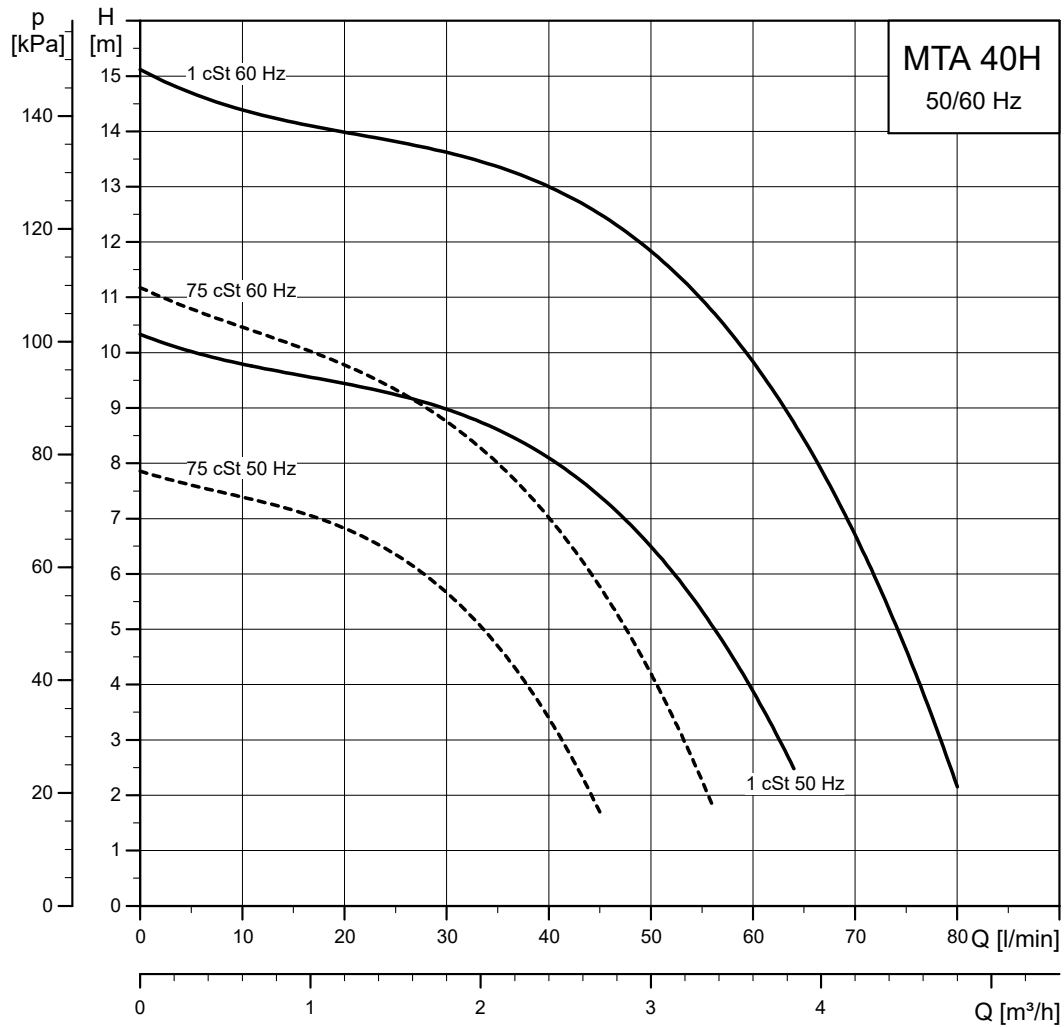

TMD050863

Dimensional sketches

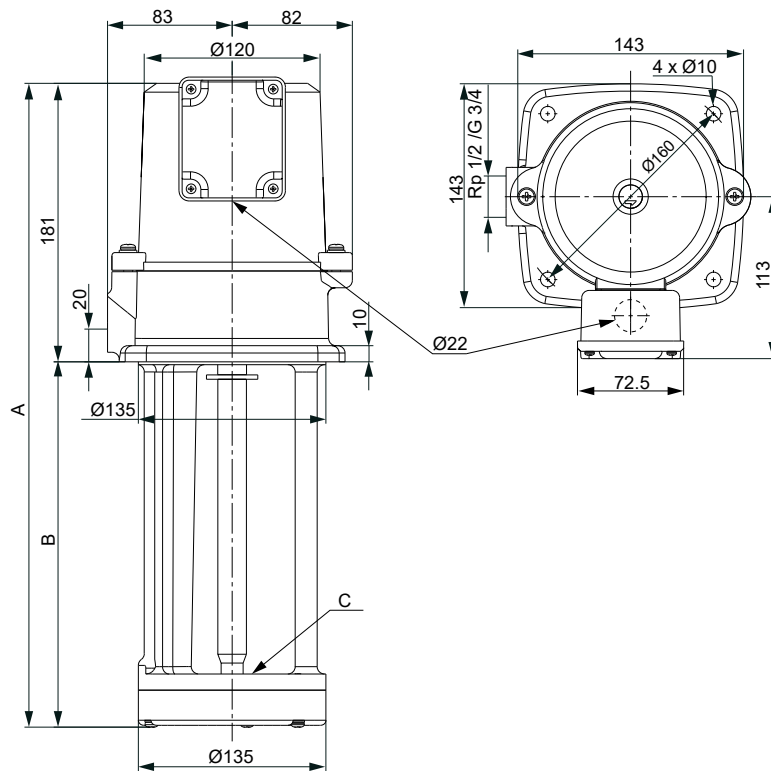

TM050885

C: Top inlet.

Dimensions and weights

Pump type	Inlet	A [mm]	B [mm]	Net weight [kg]	Gross weight [kg]	Shipping volume [m ³]
MTA 40H-180	Top	361	180	11.3	12.6	0.02

Electrical data

Voltage	Frequency [Hz]	P1 [W]	I _{1/1} [A]	I _{max} [A]	I _{start} [A]	Cos φ
3 x 200 Δ V	50	240	0.86	0.99	5.42	0.81
3 x 200-220 Δ V	60	375	1.28 - 1.2	1.47 - 1.38	6.27 - 6.36	0.85 - 0.82
3 x 220-240 Δ / 380-415Y V	50	230	0.79/0.48	0.91/0.55	5.85/3.55	0.76 - 0.7 0
3 x 220-240 Δ / 380-440Y V	60	365	1.14/0.69 - 0.63	1.31/0.79 - 0.72	6.50/3.93 - 3.59	0.84 - 0.77

MTA 70H

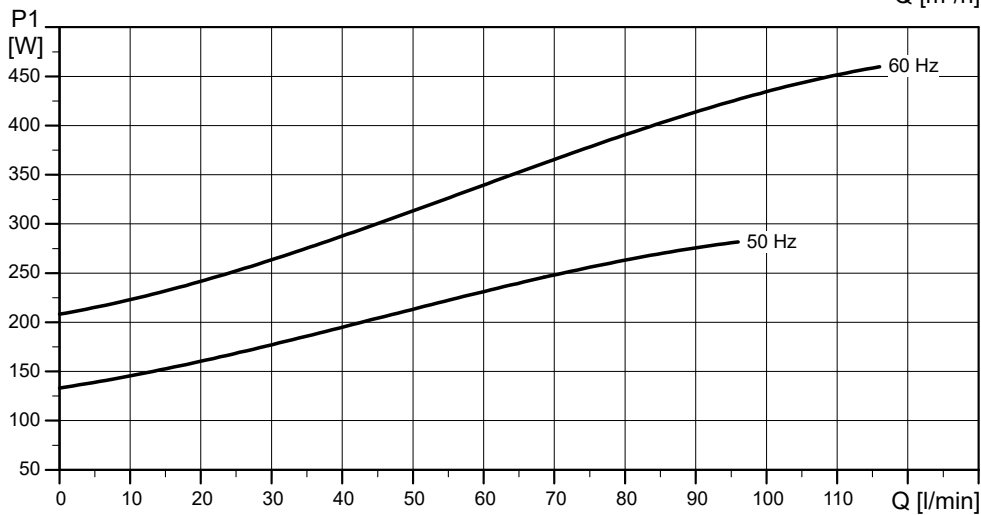
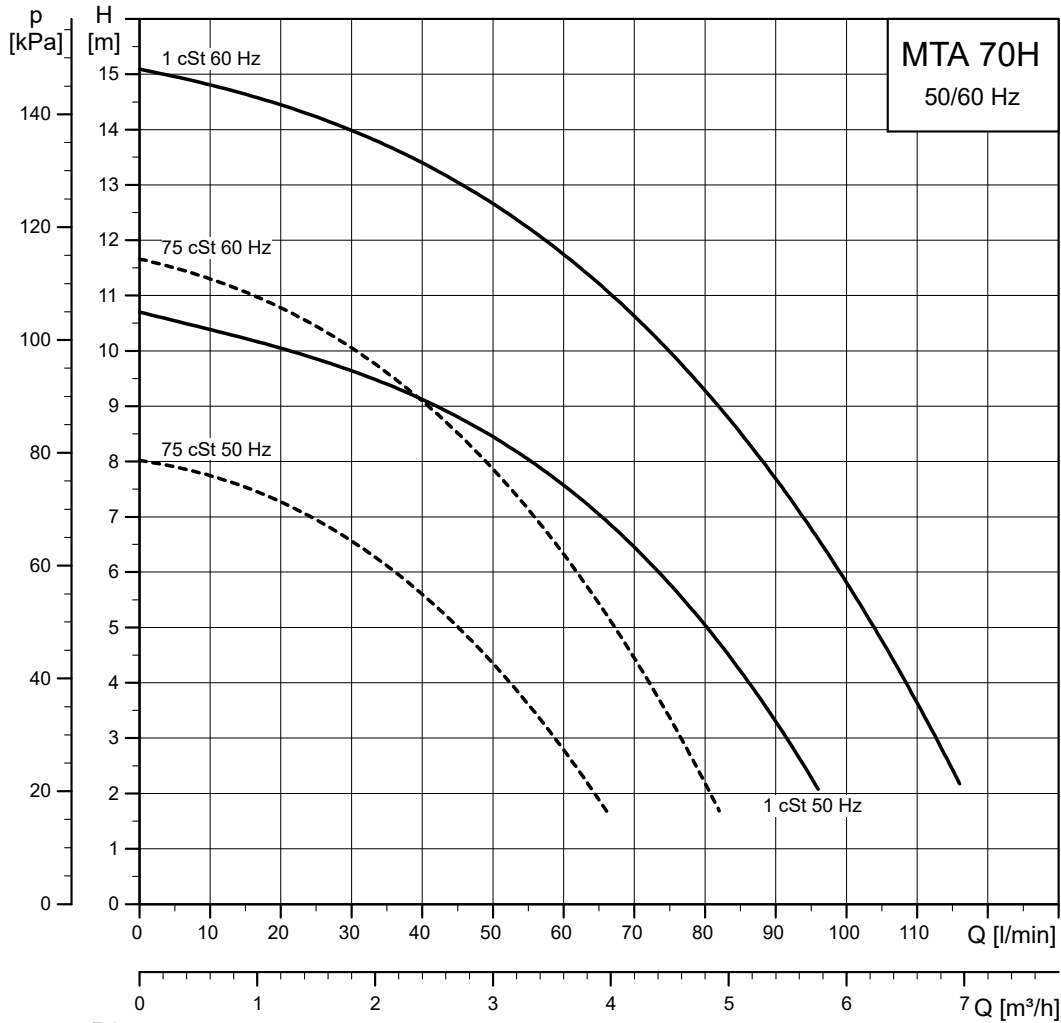

TMD050864

Dimensional sketches

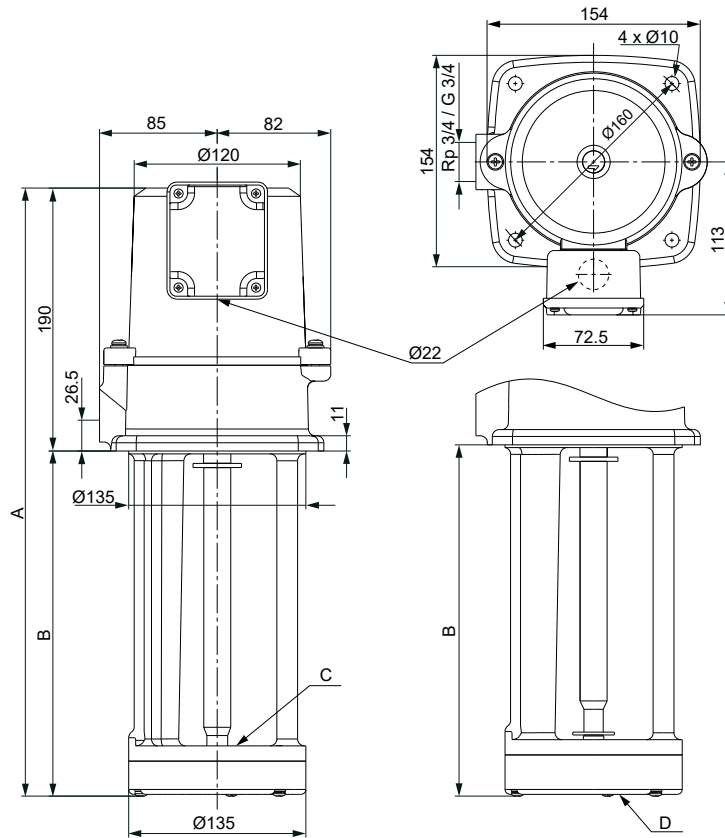

TM058318

Left: Top inlet (C). Right: Bottom inlet (D).

Dimensions and weights

Pump type	Inlet	A [mm]	B [mm]	Net weight [kg]	Gross weight [kg]	Shipping volume [m ³]
MTA 70H-250	Top	440	250	14.3	16.0	0.023
MTA 70H-250	Bottom	440	250	14.8	16.5	0.023

Electrical data

Voltage	Frequency [Hz]	P1 [W]	I _{1/1} [A]	I _{max} [A]	I _{start} [A]	Cos φ
3 x 200 Δ V	50	283	1.18	1.36	8.26	0.69
3 x 200-220 Δ V	60	460	1.63 - 1.54	1.87 - 1.77	9.29 - 9.55	0.81 - 0.78
3 x 220-240 Δ / 380-415Y V	50	281	1.02/0.59	1.17/0.68	7.65/4.43	0.72 - 0.66
3 x 220-240 Δ / 380-440Y V	60	458	1.45/0.86 - 0.74	1.67/0.99 - 0.85	8.56/5.07 - 4.37	0.83 - 0.76

MTA 100H

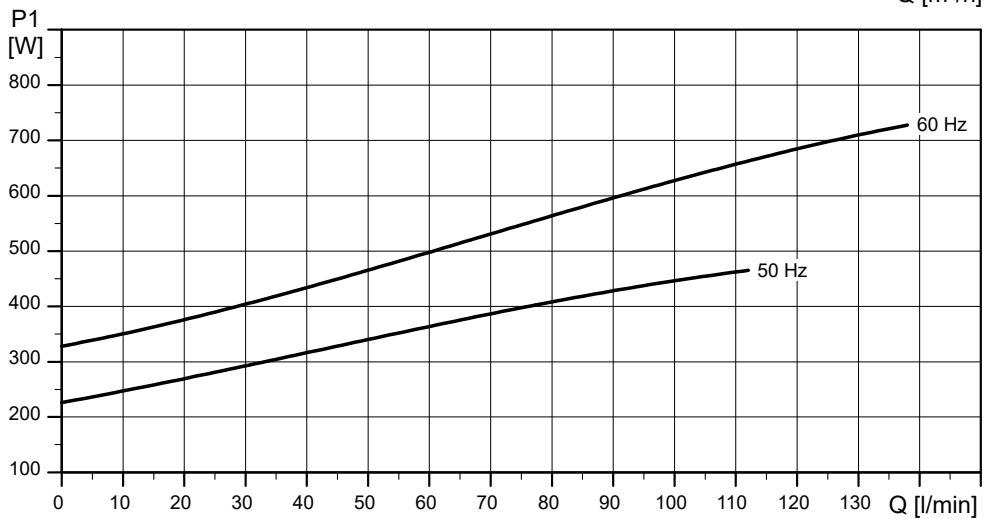
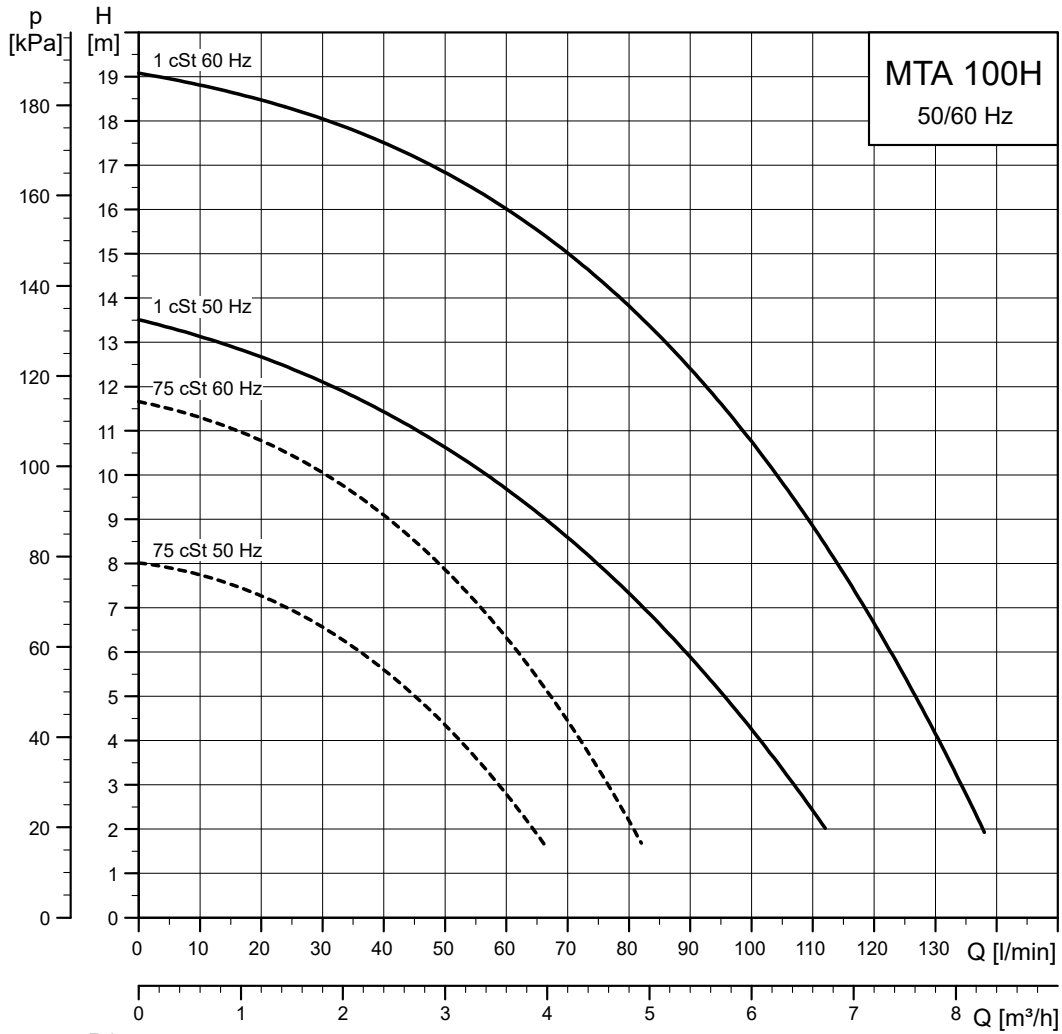

TM050865

Dimensional sketches

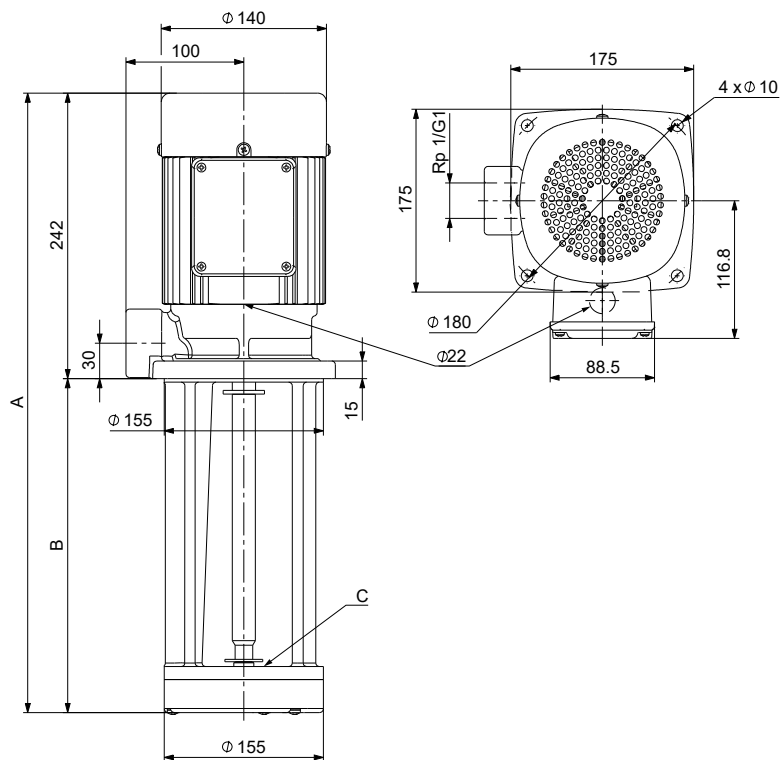

TM062756

C: Top inlet.

Dimensions and weights

Pump type	Inlet	A [mm]	B [mm]	Net weight [kg]	Gross weight [kg]	Shipping volume [m ³]
MTA 100H-180	Top	422	180	15.2	16.8	0.032
MTA 100H-280		522	280	17.5	19.1	0.032

Electrical data

Voltage	Frequency [Hz]	P1 [W]	I _{1/1} [A]	I _{max} [A]	I _{start} [A]	Cos φ
3 x 200 Δ V	50	465	1.81	2.08	12.1	0.74
3 x 200-220 Δ V	60	725	2.4 - 2.28	2.76 - 2.62	13.9 - 14.1	0.87 - 0.83
3 x 220-240 Δ / 380-415Y V	50	445	1.47/0.87	1.69/1.00	10.0/5.92	0.79 - 0.73
3 x 220-240 Δ / 380-440Y V	60	715	1.98/1.21 - 1.05	2.28/1.39 - 1.21	11.5/7.02 - 6.09	0.95 - 0.87

13. Motor data

Standard motors, MTR and SPK



Grundfos MG motor



Siemens motor

Standard motors, MTR and SPK, 50 Hz

Motor make	P2 [kW]	Frame size	Standard voltage [V]	I _{1/1} [A]	Cos φ _{1/1}	η [%]	Motor efficiency class	Starting current I _{start} [%]	Speed [min ⁻¹]
Siemens	0.12	63	220-240Δ/380-415Y	0.64-0.66/0.37-0.38	0.78	60.8	IE3	450	2830
	0.18	63	220-240Δ/380-415Y	0.94-0.96/0.55-0.56	0.78	60.4	IE2	450	2850
	0.25	71	220-255Δ/380-440Y	1.12/0.65	0.83-0.71	77.5	IE3	570-620	2840-2880
	0.37	71A	220-240Δ/380-415Y	1.74/1.00	0.80-0.70	73.8	IE3	490-530	2850-2880
	0.55	71B	220-240Δ/380-415Y	2.50/1.44	0.80-0.70	77.8	IE3	580-620	2830-2850
	0.75	80A	220-240Δ/380-415Y	3.30/1.90	0.81-0.71	80.7	IE3	580-620	2840-2870
	1.1	80C	220-240Δ/380-415Y	4.35/2.50	0.83-0.76	82.7	IE3	450-500	2840-2870
	1.5	90SD	220-240Δ/380-415Y	5.70/3.30	0.84-0.78	84.2	IE3	750-820	2890-2910
	2.2	90LE	380-415Δ	4.65	0.86-0.80	85.9	IE3	840-920	2890-2910
Grundfos MG	3.0	100LC	380-415Δ	6.30	0.87-0.82	87.1	IE3	840-920	2900-2920
	4.0	112MC	380-415Δ	7.90	0.87	88.1	IE3	1000	2920-2940
	5.5	132SC	380-415Δ	11.00	0.87-0.82	89.2	IE3	1080-1180	2920-2940
	7.5	132SB	380-415Δ/660-690Y	14.4-14/8.3-8.1	0.88-0.82	90.1	IE3	780-910	2910-2920
	11	160MB	380-415Δ/660-690Y	20.8-19.8/12-11.8	0.88-0.84	91.2	IE3	660-780	2940-2950
	15	160MD	380-415Δ/660-690Y	28-26/16.2-15.6	0.89-0.87	91.9	IE3	660-780	2930-2950
	18.5	160LB	380-415Δ/660-690Y	34.5-32.5/20-18.8	0.89-0.85	92.4	IE3	830-980	2940-2950
	22	180MB	380-415Δ/660-690Y	39.5/22.8	0.90	92.7	IE3	830	2950
	30	200L	380-420Δ/660-725Y	53-51/31-29.5	0.87	93.3	IE3	700	2955
	37	200L	380-420Δ/660-725Y	65-63/37.5-36	0.88	93.7	IE3	710	2955
Siemens	45	225M	380-420Δ/660-725Y	78-74/45-43	0.89	94.0	IE3	690	2960

Standard motors, MTR and SPK, 50 Hz, 3 x 200 V

Motor make	P2 [kW]	Frame size	Standard voltage [V]	I _{1/1} [A]	Cos φ _{1/1}	η [%]	Motor efficiency class	Starting current I _{start} [%]	Speed [min ⁻¹]
Siemens	0.12	63	200-230Δ/346-400Y	0.74-0.69/0.43-0.40	0.78	60.8	IE3	450	2830
	0.18	63	190-210Δ/330-365Y	1.10/0.64	0.78	60.4	IE2	450	2850
	0.25	71A	200-220Δ/346-380Y	1.32/0.76	0.82-0.77	77.6	IE3	530-590	2810-2850
	0.37	71A	200-220Δ/346-380Y	1.90/1.1	0.80-0.70	78.5	IE3	490-530	2850-2880
	0.55	71B	200-220Δ/346-380Y	2.75/1.58	0.80-0.70	80.0	IE3	480-520	2830-2850
	0.75	80A	200-220Δ/346-380Y	3.35-3.65/1.94-2.1	0.79-0.67	80.7	IE3	660-670	2820-2860
	1.1	80C	200-220Δ/346-380Y	4.65/2.7	0.83-0.75	82.7	IE3	720-800	2830-2860
Grundfos MG	1.5	90LC	200-220Δ/346-380Y	6.00-5.85/3.45-3.40	0.86-0.80	84.2	IE3	880-990	2910-2930
	2.2	90LC	200-220Δ/346-380Y	8.95-9.10/5.15-5.25	0.84-0.76	85.9	IE3	880-950	2910-2930
	3	100LC	200-220Δ/346-380Y	11.6/6.65	0.85-0.77	87.1	IE3	1130-1270	2920-2940
	4	112MC	200-220Δ/346-380Y	14.6-14/8.5-8.1	0.88-0.84	88.1	IE3	1040-1220	2930-2940
	5.5	132SC	200-220Δ/346-380Y	20.4-19.8/11.8-11.4	0.88-0.82	89.2	IE3	1020-1170	2910-2930
	7.5	132SB	200-220Δ/346-380Y	29-32/16.8-18.2	0.82-0.69	90.1	IE3	910-930	2930-2940
	Hebei	11	160M	200ΔΔ/400Δ	40.10/19.9	0.86	91.2	IE3	735
15		160M	200ΔΔ/400Δ	53.5/26.8	0.87	91.9	IE3	703	2950
18.5		160L	200ΔΔ/400Δ	67.7/33.9	0.87	92.4	IE3	709	2950
22		180M	200ΔΔ/400Δ	74.6/37.5	0.90	92.7	IE3	884	2960
30		200L	200ΔΔ/400Δ	104/51.9	0.89	93.3	IE3	809	2960
37		200L	200ΔΔ/400Δ	127/63.9	0.89	93.7	IE3	854	2960
45		225M	200ΔΔ/400Δ	153/76.8	0.90	94	IE3	764	2960

Standard motors, MTR, 50 Hz

Motor make	P2 [kW]	Frame size	Standard voltage [V]	I _{1/1} [A]	Cos φ _{1/1}	η [%]	Motor efficiency class	Starting current I _{start} [%]	Speed [min ⁻¹]
Siemens	3	100L	380-420D/660-725Y	5.70/3.3	0.86	89.1-89.1	IE4	900-900	2920
	4	112M	380-420D/660-725Y	7.20/4.2	0.89	90.0-90.0	IE4	880-880	2950
	5.5	132S	380-420D/660-725Y	10.4/6	0.84	90.9-90.9	IE4	860-860	2960
	7.5	132S	380-420D/660-725Y	13.0/7.5	0.91	91.7-91.7	IE4	860-860	2955
	11	160M	380-420D/660-725Y	19.1/11	0.90	92.6-92.6	IE4	860-860	2955
	15	160M	380-420D/660-725Y	26.0/14.9	0.90	93.3-93.3	IE4	900-900	2955
	18.5	160L	380-420D/660-725Y	31.5/18.2	0.91	93.7-93.7	IE4	890-890	2955
	22	180M	380-420D/660-725Y	38.0/22.0	0.89	94.0-94.0	IE4	890-890	2950
	30	200L	380-420D/660-725Y	54.0/31.5	0.85	94.5-94.5	IE4	790-790	2955
	37	200L	380-420D/660-725Y	64.0/37.0	0.88	94.8-94.8	IE4	780-780	2955
	45	225M	380-420D/660-725Y	80.0/46.5	0.85	94.5-94.5	IE4	880-880	2970

Standard motors, MTR and SPK, 60 Hz

Motor make	P2 [kW]	Frame size	Standard voltage [V]	I _{1/1} [A]	Cos φ _{1/1}	η [%]	Motor efficiency class	Starting current I _{start} [%]	Speed [min ⁻¹]
Siemens	0.12	63	220-277Δ/380-480Y	0.59-0.61/0.34-0.35	0.83	62	IE3	450	3395
	0.18	63	220-277Δ/380-480Y	0.86-0.88/0.50-0.51	0.83	64	IE2	450	3420
Grundfos MG	0.25	71A	220-255Δ/380-440Y	1.10-1.02/0.63-0.59	0.86-0.77	77.7	IE3	570-620	3400-3450
	0.37	71A	220-255Δ/380-440Y	1.50-1.44/0.87-0.83	0.85-0.76	73.4	IE3	550-650	3410-3470
	0.55	71B	220-255Δ/380-440Y	2.15-2.05/1.25-1.20	0.85-0.76	76.8	IE3	500-600	3390-3460
	0.75	80A	220-255Δ/380-440Y	2.95-2.75/1.70-1.60	0.86-0.77	77.0	IE3	600-740	3410-3470
	1.1	80C	230-255Δ/400-440Y	4.10-4.00/2.38-2.30	0.86-0.80	84.0-84.0	IE3	440-500	3430-3470
	1.5	90SD	230-277Δ/400-480Y	5.30-5.00/3.05-2.90	0.85-0.75	85.5	IE3	780-980	3480-3530
	2.2	90LE	400-480Δ	4.30-4.00	0.88-0.80	86.5	IE3	730-1050	3480-3530
	3	100LC	400-480Δ	6.00-5.40	0.90-0.84	88.5-88.5	IE3	910-1100	3490-3530
	4	112MC	380-480Δ	7.80-6.80	0.91-0.82	88.5	IE3	1000-1470	3510-3540
	5.5	132SC	380-480Δ	10.6-9.30	0.90-0.80	89.5	IE3	1020-1480	3510-3550
Grundfos MG	7.5	132SB	400-480Δ/690Y	13.8-12/8.1	0.88-0.82	90.2-90.2	IE3	750-1050	3500-3530
	11	160MB	400-480Δ/690Y	20.1-17.2/11.6	0.88-0.83	91.0-91.0	IE3	640-890	3530-3550
	15	160MD	400-480Δ/690Y	26.9-22.4/15.6	0.89-0.86	91.0-91.0	IE3	640-890	3530-3550
	18.5	160LB	400-480Δ/690Y	33.2-28/16.6	0.88-0.84	91.7-91.7	IE3	760-1100	3530-3560
	22	180MB	380-480Δ/660-690Y	40-32.5/23-22.2	0.91	91.7	IE3	650	3520-3560
	30 ³⁶⁾	200L	440-480Δ	47-29	0.87	92.4	IE3	850	3560
	37 ³⁶⁾	200L	440-480Δ	57-35	0.88	93	IE3	760	3560
	45 ³⁶⁾	225M	440-480Δ	69-43	0.88	93.6	IE3	760	3570

³⁶⁾Siemens motors operating at 440-480Δ voltage may be loaded with a service factor of 1.15.

Standard motors, MTR and SPK, 60 Hz, 3 x 200 V

Motor make	P2 [kW]	Frame size	Standard voltage [V]	I _{1/1} [A]	Cos φ _{1/1}	η [%]	Motor efficiency class	Starting current I _{start} [%]	Speed [min ⁻¹]
Siemens	0.12	63	200-230Δ/346-400Y	0.73-0.68/0.42-0.40	0.76	62	IE3	450	3445
	0.18	63	200-230Δ/346-400Y	0.98-0.97/0.57-0.56	0.83	64	IE2	450	3420
Grundfos MG	0.25	71A	200-230Δ/346-400Y	1.30/0.75	0.80-0.86	77.9-79.5	IE3	530-590	3380-3450
	0.37	71A	200-230Δ/346-400Y	1.65-1.50/0.96-0.87	0.76-0.85	79.0-80	IE3	490-530	3410-3470
	0.55	71B	200-230Δ/346-400Y	2.36-2.14/1.36-1.24	0.76-0.85	81.5-83	IE3	480-520	3390-3460
	0.75	80A	200-220Δ/346-380Y	3.2-2.95/1.82-1.7	0.77-0.84	77	IE3	660-670	3380-3450
	1.1	80C	200-220Δ/346-380Y	4.5-4.15/2.6-2.38	0.81-0.86	84	IE3	720-800	3380-3450
	1.5	90LC	200-220Δ/346-380Y	5.80-5.40/3.35-3.10	0.86-0.89	85.5	IE3	880-990	3490-3510
	2.2	90LC	200-220Δ/346-380Y	8.60-8.00/5.00-4.60	0.85-0.89	86.5	IE3	880-950	3490-3510
	3	100LC	200-220Δ/346-380Y	11.4-10.4/6.55-6	0.86-0.88	88.5	IE3	1130-1270	3500-3520
	4	112MC	200-220Δ/346-380Y	14.6-13/8.45-7.50	0.87-0.9	88.5	IE3	1040-1220	3510-3540
	5.5	132SC	200-220Δ/346-380Y	20.2-18/11.6-10.4	0.87-0.9	89.5	IE3	1020-1170	3490-3520
Grundfos MG	7.5	132SB	200-220Δ/346-380Y	26.5-25/15.4-14.4	0.82-0.89	90.2	IE3	910-930	3520-3540
	11	160M	200-220Δ/400-440Δ	39.2-35.9/19.5-17.8	0.87-0.88	91	IE3	735	3540-3550
	15	160M	200-220Δ/400-440Δ	53.1-48.3/26.6-24.2	0.88-0.89	91	IE3	703	3540-3550
	18.5	160L	200-220Δ/400-440Δ	65.3-60.2/32.8-30.2	0.81-0.89	91.7	IE3	709	3540-3550
	22	180M	200-220Δ/400-440Δ	75.2-68.7/38.0-34.5	0.89-0.91	91.7	IE3	884	3540-3550
	30	200L	200-220Δ/400-440Δ	102-93.9/51.1-47	0.89-0.91	92.4	IE3	809	3550-3560
	37	200L	200-220Δ/400-440Δ	126-115/62.8-57.6	0.90-0.91	93	IE3	854	3550-3560
	45	225M	200-220Δ/400-440Δ	154-139/76.7-69.6	0.90	93.6	IE3	764	3560

Standard motors, MTR, 60 Hz

Motor make	P2 [kW]	Frame size	Standard voltage [V]	I _{1/1} [A]	Cos φ _{1/1}	η [%]	Motor efficiency class	Starting current I _{start} [%]	Speed [min ⁻¹]
Siemens	3	100L	440-480D	4.95	0.85	89.5-89.5	IE4	1080-1080	3530
	4	112M	440-480D	5.90	0.88	89.5-89.5	IE4	1100-1100	3560
	5.5	132S	440-480D	9.20	0.83	90.2-90.2	IE4	990-990	3565
	7.5	132S	440-480D	11.4	0.90	91.7-91.7	IE4	1000-1000	3560
	11	160M	440-480D	16.8	0.89	92.4-92.4	IE4	980-980	3560
	15	160M	440-480D	23.0	0.89	92.4-92.4	IE4	1000-1000	3560
	18.5	160L	440-480D	27.5	0.90	93.0-93.0	IE4	1010-1010	3560
	22	180M	440-480D	33.5	0.88	93.0-93.0	IE4	980-980	3560
	30	200L	440-480D	48.0	0.84	93.6-93.6	IE4	870-870	3565
	37	200L	440-480D	57.0	0.87	94.1-94.1	IE4	900-900	3560
	45	225M	440-480D	70.0	0.85	94.5-94.5	IE4	980-980	3575

Motors, MTH, 50 Hz

Motor make	P2 [kW]	Frame size	Standard voltage [V]	I _{1/1} [A]	Cos φ _{1/1}	η ³⁷⁾ [%]	I _{start} [A]	Speed [min ⁻¹]
MG	0.55	71	220-240Δ/380-415Y	2.50/1.44	0.8-0.70/0.76-0.85	80.0-80.0/81.5-83	14.5-8.4/15.5-8.9	2830-2880
MG	0.75	80	220-240Δ/380-415Y	3.30/1.90	0.81-0.71/0.77-0.86	81.7-81.2/82.9-83.5	19.1-11/20.5-11.8	2840-2870
MG	1.1	80	220-240Δ/380-415Y	4.35/2.50	0.83-0.76/0.80-0.86	82.8-83.4/84.0-85.7	19.6-11.5/21.8-12.8	2840-2870
MG	1.5	90	220-240Δ/380-415Y	5.45/3.15	0.86-0.80/0.79-0.90	84.2-84.2/85.5-85.5	46.1-26.6/52.7-30.4	2910-2930
MG	2.2	90	220-240Δ/380-415Y	7.70/4.45	0.86-0.80/0.80-0.90	85.9-85.9/86.5-86.5	67.2-38.6/73.6-42.3	2890-2910
MG	3	100	220-240Δ/380-415Y	11.0/6.30	0.87-0.82/0.79-0.90	86.6-86.8/88.5	92.4-52.9/101.2-58	2900-2920
MG	4	112	220-240Δ/380-415Y	13.6/7.90	0.87-0.87/0.82-0.91	88.3-88.6/88.5	136-79/151-87.7	2920-2940

37) Motor efficiency class: IE3

Motors, MTH, 60 Hz

Motor make	P2 [kW]	Frame size	Standard voltage [V]	I _{1/1} [A]	Cos φ _{1/1}	η ³⁸⁾ [%]	I _{start} [A]	Speed [min ⁻¹]
MG	0.55	71	220-255Δ/380-440Y	2.15-2.05/1.25-1.20	0.8-0.70/0.76-0.85	80.0-80.0/81.5-83	10.8-6.3/12.3-7.2	3390-3460
MG	0.75	80	220-255Δ/380-440Y	2.95-2.75/1.70-1.60	0.81-0.71/0.77-0.86	81.7-81.2/82.9-83.5	17.7-10.2/20.4-11.8	3410-3470
MG	1.1	80	230-255Δ/400-440Y	4.10-4.00/2.38-2.30	0.83-0.76/0.80-0.86	82.8-83.4/84.0-85.7	18-10.5/20-11.5	3430-3470
MG	1.5	90	220-277Δ/380-480Y	5.35-4.70/3.10-2.70	0.86-0.80/0.79-0.90	84.2-84.2/85.5-85.5	42.3-24.5/51.7-29.7	3500-3540
MG	2.2	90	220-277Δ/380-480Y	7.70-6.95/4.45-4.00	0.86-0.80/0.80-0.90	85.9-85.9/86.5-86.5	57.8-33.4/73-42	3470-3530
MG	3	100	230-277Δ/400-480Y	10.5-9.35/6.00-5.40	0.87-0.82/0.79-0.90	86.6-86.8/88.5-88.5	95.6-54.6/102.9-59.4	3490-3530
MG	4	112	220-277Δ/380-480Y	13.6-11.8/7.80-6.80	0.87-0.87/0.82-0.91	88.3-88.6/88.5-88.5	136-78/173.5-100	3510-3540

38) Motor efficiency class: IE3

Motors, MTH, 50 Hz, 3 x 200 V

Motor make	P2 [kW]	Frame size	Standard voltage [V]	$I_{1/1}$ [A]	$\cos \phi_{1/1}$	$\eta^{39)}$ [%]	I_{start} [A]	Speed [min ⁻¹]
MG	0.55	71	200-220Δ/346-380Y	2.75-2.75/1.58-1.58	0.80-0.70/0.76-0.85	80.0-80.0/81.5-83	13.2-7.6/14.3-8.2	2830-2880
MG	0.75	80	200-220Δ/346-380Y	3.55-3.65/2.06-2.1	0.81-0.71/0.77-0.86	81.7-81.2/82.9-83.5	23.4-13.6/24.5-14.1	2840-2860
MG	1.1	80	200-220Δ/346-380Y	4.65/2.7	0.83-0.76/0.77-0.88	82.8-83.4/84.0-84.0	20.9-12.2/37.2-21.6	2840-2870
MG	1.5	90	200-220Δ/346-380Y	6.00-5.85/3.45-3.40	0.86-0.80/0.86-0.89	84.2-84.2/85.5-85.5	52.8-30.4/59.4-34.2	2910-2930
MG	2.2	90	200-220Δ/346-380Y	8.95-9.10/5.15-5.25	0.84-0.76/0.85-0.89	85.9-85.9/86.5-86.5	78.8-45.3/85-48.9	2910-2930
MG	3	100	200-220Δ/346-380Y	12-13.4/6.9-7.7	0.8-0.7/0.82-0.88	87.8-87.6/88.5	170.4-98/169.2-97.3	2940-2950
MG	4	112	200-220Δ/346-380Y	14.6-14/8.5-8.1	0.88-0.84/0.87-0.9	88.3-88.6/88.5	151.8-88.4/178.1-103.7	2930-2940

³⁹⁾ Motor efficiency class: IE3

Motors, MTH, 50/60 Hz, 3 x 200 V

Note that the motors can operate at both 50 and 60 Hz, and therefore two data sets are provided for each frame size.

Motor make	Frequency [Hz]	P2 [kW]	Frame size	Standard voltage [V]	$I_{1/1}$ [A]	$\cos \phi_{1/1}$	$\eta^{40)}$ [%]	I_{start} [A]	Speed [min ⁻¹]
MG	50	0.37	71	200-220Δ/346-380Y	1.88-2.2/1.08-1.26	0.73-0.59/0.76-0.85	78-74.9/81.5-83	15.8-9.1/15-8.6	2900-2920
	60	0.55		200-230Δ/346-400Y	2.36-2.14/1.36-1.24	0.73-0.59/0.76-0.85	78-74.9/81.5-83	11.8-6.8/12.8-7.4	3390-3460
MG	50	0.55	80	200-220Δ/346-380Y	2.7-2.95/1.56-1.7	0.67-0.51/0.77-0.86	82.7-80.9/77.0-77.0	21.1-12.2/18.4-10.6	2880-2900
	60	0.75		200-220Δ/346-380Y	3.2-2.95/1.82-1.7	0.67-0.51/0.77-0.86	82.7-80.9/77.0-77.0	20.2-11.5/23.6-13.6	3410-3470
MG	50	0.75	80	200-220Δ/346-380Y	3.5-3.7/2-2.14	0.74-0.64/0.77-0.88	84.2-83.1/84.0-84.0	33.6-19.2/35.4-20.2	2890-2910
	60	1.1		200-220Δ/346-380Y	4.5-4.35/2.6-2.5	0.74-0.64/0.77-0.88	84.2-83.1/84.0-84.0	30.2-17.4/38.7-22.3	3380-3450
MG ⁴¹⁾	50	0.75	80	200Δ/346Y	5.1/2.95	0.56-0.73/0.81	81-82.9/83.5	33.2-19.2/0-0	2910-2910
	60	1.1		200-220Δ/346-380Y	5.05-5/2.9-2.9	0.56-0.73/0.81	81-82.9/83.5	25.8-14.8/30-17.4	3520-3540
MG	50	1.1	90	200-220Δ/346-380Y	4.85-5.00/2.80-2.90	0.77-0.68/0.86-0.89	82.7-82.7/85.5-85.5	48.5-28/50.9-29.4	2940-2950
	60	1.5		200-220Δ/346-380Y	5.80-5.40/3.35-3.10	0.77-0.68/0.86-0.89	82.7-82.7/85.5-85.5	46.4-26.8/50.8-29.1	3510-3540
MG	50	1.5	90	200-220Δ/346-380Y	7.00-7.80/4.00-4.50	0.72-0.60/0.85-0.89	84.2-84.2/86.5-86.5	73.5-42/73.5-42	2940-2950
	60	2.2		200-220Δ/346-380Y	8.60-8.00/5.00-4.60	0.72-0.60/0.85-0.89	84.2-84.2/86.5-86.5	66.2-38.5/72.8-41.9	3420-3450
MG	50	2.2	100	200-220Δ/346-380Y	10-13/5.75-7.5	0.73-0.53/0.82-0.88	87-85.9/88.5-88.5	170-97.8/145-83.4	2960-2960
	60	3		200-220Δ/346-380Y	11.8-11/6.85-6.1	0.73-0.53/0.82-0.88	87-85.9/88.5-88.5	148.7-86.3/183.7-101.9	3490-3510
MG	50	3	112	200-220Δ/346-380Y	11.6-11.4/6.65-6.6	0.84-0.81/0.87-0.9	88.6-88.2/88.5-88.5	154.3-88.4/172.8-99.1	2950-2960
	60	4		200-220Δ/346-380Y	14.6-13/8.45-7.45	0.84-0.81/0.87-0.9	88.6-88.2/88.5-88.5	129.9-75.2/154.7-88.7	3490-3510

⁴⁰⁾ Motor efficiency class: IE3

⁴¹⁾ Special compact version.

E-motors, MTRE

Grundfos MGE motor

E-motors, 50/60 Hz

Motor make	P2 [kW]	Frame size	Phase	Standard voltage [V]	I _{1/1} [A]	Cos φ _{1/1}	η [%]	Motor efficiency class
Grundfos MGE	0.37 ⁴²⁾	71	1	200-240	2.4 - 2.1	0.96	84	IE5
	0.55 ⁴²⁾	71	1	200-240	3.45 - 2.9	0.98	85.3	IE5
	0.75 ⁴²⁾	80	1	200-240	4.7 - 3.9	0.99	85.2	IE5
	1.1 ⁴²⁾	80	1	200-240	6.7 - 5.6	0.99	86.9	IE5
	1.5 ⁴²⁾	90	1	200-240	9.1 - 7.6	0.99	87.4	IE5
	0.37	71	3	380-500	1.05 - 1.0	0.68 - 0.54	84.5	IE5
	0.55	71	3	380-500	1.35 - 1.3	0.77 - 0.61	85.9	IE5
	0.75	80	3	380-500	1.7 - 1.6	0.83 - 0.67	85.9	IE5
	1.1	80	3	380-500	2.2 - 1.9	0.89 - 0.79	89.1	IE5
	1.5	90	3	380-500	2.9 - 2.4	0.92 - 0.85	88.9	IE5
	2.2	90	3	380-500	4.15 - 3.4	0.93 - 0.87	90.1	IE5
	3	100	3	380-500	5.8 - 4.8	0.91 - 0.86	90.7	IE5
	4	112	3	380-500	7.6 - 6.2	0.92 - 0.87	92.2	IE5
	5.5	132	3	380-500	10.3 - 8.2	0.92 - 0.88	92.7	IE5
	7.5	132	3	380-500	14.1 - 11.2	0.93 - 0.89	92.5	IE5
	11	160	3	380-500	20.3 - 16.0	0.93 - 0.90	93.1	IE5
	15	160	3	380-500	26.7 - 22.0	0.94 - 0.92	92.8	IE5
	18.5	160	3	380-500	33.0 - 27.8	0.94 - 0.92	92.8	IE5
	22	180	3	380-500	39.2 - 31.5	0.94 - 0.93	92.9	IE5

⁴²⁾ Pumps are normally fitted with three-phase MGE motors. Dimension tables in the section on performance curves and technical data show pumps with three-phase MGE motors.

E-motors, 50/60 Hz, 3 x 200-240 V

Motor make	P2 [kW]	Frame size	Phase	Standard voltage [V]	I _{1/1} [A]	Cos φ _{1/1}	η [%]	Motor efficiency class
Grundfos MGE	1.1	80	3	200-240	4.1 - 3.5	0.92 - 0.91	89.3	IE5
	1.5	90	3	200-240	5.4 - 4.6	0.92 - 0.92	88.9	IE5
	2.2	90	3	200-240	7.8 - 6.5	0.94 - 0.94	88.8	IE5
	3.0	100	3	200-240	10.5 - 8.8	0.94 - 0.94	90.3	IE5
	4.0	112	3	200-240	14.1 - 11.8	0.94 - 0.94	90.8	IE5
	5.5	132	3	200-240	19.6 - 16.3	0.94 - 0.94	90.2	IE5

14. Accessories

Pipe connection

Various sets of counterflanges and couplings are available for pipe connection.

Counterflanges for MTR, MTRE, SPK

A counterflange set consists of one counterflange, one gasket, bolts and nuts. Counterflange sets are available in cast iron (EN-GJL-200) and some are also available in stainless steel (EN/DIN 1.4301/AISI 304).

Counterflange	Pump type	Description	Rated pressure	Pipe connection	Material	Product number			
	TM046337	SPK 1 SPK 2 SPK 4	Threaded	25 bar	Cast iron	Rp 3/4 G 3/4	91535542 45390139		
					Cast iron	NPT 3/4	45390138		
					MTR, MTRE 1s		Rp 1 1/4	405178	
	TM046336	MTR, MTRE 1 MTR, MTRE 3 MTR, MTRE 5 MTR, MTRE 8	Threaded	16 bar	Cast iron	G 1 1/4	98508757		
					Cast iron	NPT 1 1/4	99264144		
					MTR, MTRE 10		Rp 2	98767494	
					MTR, MTRE 15		G 2	98796348	
					MTR, MTRE 20		NPT 2	98796349	
	TM062823	MTR, MTRE 10 MTR, MTRE 15 MTR, MTRE 20	Threaded	16 bar, EN 1092-2	Cast iron	Rp 2 1/2	349902		
					Stainless steel		349910		
					MTR, MTRE 32		Threaded	16 bar, EN 1092-2	Rp 2 1/2
	TM032116	MTR, MTRE 32	Threaded	16 bar, special flange	Cast iron	Rp 3	349911		
					Stainless steel		349911		
					Cast iron	16 bar, EN 1092-2	65 mm, nominal	Stainless steel	349904
					Stainless steel		349906		
					Cast iron	40 bar, DIN 2635	65 mm, nominal	Stainless steel	349905
					Stainless steel		349908		
					Cast iron	16 bar, special flange	80 mm, nominal	Stainless steel	349903
					Stainless steel		349907		
					Stainless steel	25 bar, special flange	80 mm, nominal	Stainless steel	349909

Rp 2 1/2 / 16 bar Rp 3 / 16 bar 25/40 bar

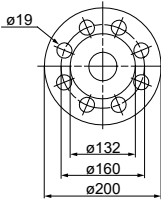
Counterflange	Pump type	Description	Rated pressure	Pipe connection	Material	Product number	
	MTR, MTRE 45 MTR, MTRE 64	TM032117	Threaded	16 bar	Rp 3	Cast iron	350540
						Stainless steel	350543
			For welding	16 bar	80 mm, nominal	Cast iron	350541
						Stainless steel	350544
						Cast iron	350542
						Stainless steel	350545

Sensors

Sensor	Type	Supplier	Measuring range	Product number
Flowmeter	SITRANS FM MAGFLO MAG 5100 W	Siemens	1-5 m ³ (DN 25)	ID8285
	SITRANS FM MAGFLO MAG 5100 W		3-10 m ³ (DN 40)	ID8286
	SITRANS FM MAGFLO MAG 5100 W		6-30 m ³ (DN 65)	ID8287
	SITRANS FM MAGFLO MAG 5100 W		20-75 m ³ (DN 100)	ID8288
Temperature sensor	TTA (0) 25	Carlo Gavazzi	0-25 °C	96432591
	TTA (-25) 25		-25 to +25 °C	96430194
	TTA (50) 100		50-100 °C	96432592
	TTA (0) 150		0-150 °C	96430195
Accessory for temperature sensor. All with 1/2 RG connection	Protecting tube Ø9 x 50 mm	Carlo Gavazzi		96430201
	Protecting tube Ø9 x 100 mm			96430202
	Cutting ring bush			96430203
Temperature sensor, ambient temperature	WR 52	tmg DK: Plesner	-50 to +50 °C	ID8295
Differential-temperature sensor	ETSD	Honsberg	0-20 °C	96409362
			0-50 °C	96409363

Note that all sensors have 4-20 mA signal output.

Grundfos Vortex Flow sensor, VFI

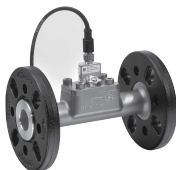
Grundfos Vortex Flow sensor, VFI ⁴³⁾	Type	Flow range [m ³ /h]	Pipe connection	O-ring		Connection type		Product number	
				EPDM	FKM	Cast-iron flange	Stainless-steel flange		
	VFI 1.3-25 DN32 020 E	1.3 - 25	DN 32	•		•		97686141	
	VFI 1.3-25 DN32 020 F				•		•	97686142	
	VFI 1.3-25 DN32 020 E				•			•	97688297
	VFI 1.3-25 DN32 020 F				•			•	97688298
	VFI 2-40 DN40 020 E	2 - 40	DN 40	•		•		97686143	
	VFI 2-40 DN40 020 F				•		•	97686144	
	VFI 2-40 DN40 020 E				•			•	97688299
	VFI 2-40 DN40 020 F				•			•	97688300
	VFI 3.2-64 DN50 020 E	2 - 64	DN 50	•		•		97686145	
	VFI 3.2-64 DN50 020 F				•		•	97686146	
	VFI 3.2-64 DN50 020 E				•			•	97688301
	VFI 3.2-64 DN50 020 F				•			•	97688302
	VFI 5.2-104 DN65 020 E	5.2 - 104	DN 65	•		•		97686147	
	VFI 5.2-104 DN65 020 F				•		•	97686148	
	VFI 5.2-104 DN65 020 E				•			•	97688303
	VFI 5.2-104 DN65 020 F				•			•	97688304
VFI 8-160 DN80 020 E	8 - 160	DN 80	•		•		97686149		
VFI 8-160 DN80 020 F				•		•	97686150		
VFI 8-160 DN80 020 E				•			•	97688305	
VFI 8-160 DN80 020 F				•			•	97688306	
VFI 12-240 DN100 020 E	12 - 240	DN 100	•		•		97686151		
VFI 12-240 DN100 020 F				•		•	97686152		
VFI 12-240 DN100 020 E				•			•	97688308	
VFI 12-240 DN100 020 F				•			•	97688309	

⁴³⁾ For more information about the VFI sensor, see the Grundfos Direct Sensors™ data booklet, publication number 97790189 in Grundfos Product Center at www.grundfos.com.

Grundfos pressure sensor kits

Content	Liquid temperature	Pressure [bar]	Product number
Grundfos pressure transmitter, type ISP44, with 2.5 m cable. Connection: G 1/2 A (DIN 16288 - B6kt) Quick guide	-40 to +100 °C ⁴⁴⁾	0-4	92618271
		0-6	92652122
		0-10	92652150
		0-16	92652152
		0-25	92618276

⁴⁴⁾ Liquid temperature ranges from -40 to +130 °C at ambient temperatures up to 25 °C.

DPI differential-pressure sensor kit

Content	Pressure [bar]	Product number
1 sensor incl. 0.9 m screened cable (7/16" connections)	0 - 0.6	96611522
1 original DPI bracket for wall mounting	0 - 1.0	96611523
1 Grundfos bracket for mounting on motor	0 - 1.6	96611524
2 M4 screws for mounting of sensor on bracket	0 - 2.5	96611525
1 M6 screw (self-cutting) for mounting on MGE 90/100	0 - 4.0	96611526
1 M8 screw (self-cutting) for mounting on MGE 112/132	0 - 6.0	96611527
3 capillary tubes (short/long)		
2 fittings (1/4" - 7/16")		
5 cable clips (black)		
Installation and operating instructions (00480675)	0-10	96611550
Service kit instructions.		

Danfoss pressure sensor kits

Content	Liquid temperature	Pressure [bar]	Product number
<ul style="list-style-type: none"> Danfoss pressure sensor, type MBS 3000, with 2 m screened cable. Connection: G 1/2 A (DIN 16288 - B6kt) 5 cable clips (black) Instructions PT (400212) 	-40 to +85 °C	0-4	96428014
		0-6	96428015
		0-10	96428016
		0-16	96428017
		0-25	96428018

EMC filter

The EMC filter is required when 11 to 22 kW E-pumps are installed in residential areas.

Product	Product number
EMC filter (11 kW)	96478309
EMC filter (15 kW)	
EMC filter (18.5 kW)	
EMC filter (22 kW)	

Product numbers

Grundfos GO variant	Product number
Grundfos MI 301	98046408

MGE 15 to 26 kW

These motors will connect to the pump via Bluetooth (BLE).

Remote controls

Grundfos GO

Use Grundfos GO for the following types of wireless communication with the pump:

- infrared
- radio
- Bluetooth.

MGE 0.37 to 11 kW

These motors will connect to the pump through wireless infrared or radio communication.

MI 301

MI 301 is a module with built-in infrared and radio communication. It is required for Grundfos GO communication. MI 301 can be used together with Android or iOS-based smart devices with a Bluetooth connection. MI 301 has a rechargeable Li-ion battery and must be charged separately.



TM053890

MI 301

Supplied with the product:

- Grundfos MI 301
- sleeve
- battery charger
- quick guide.

CIM communication interface modules

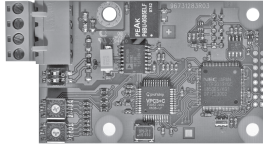

GRA6121

Grundfos CIM communication interface module

The CIM modules enable communication of operating data, such as measured values and setpoints, between the pumps and a building management system. The CIM modules are add-on communication modules which are fitted in the terminal box of the pumps.

Note that CIM modules must be fitted by authorised persons.

We offer the following CIM modules:

CIM 100

For communication via LONWorks.

CIM 150

For communication via PROFIBUS DP.

CIM 200

For communication via Modbus RTU.

CIM 300

For communication via BACnet MS/TP.

CIM 500

Ethernet module for communication via PROFINET, Modbus TCP, BACnet IP, EtherNet/IP GRM IP, Grundfos iSOLUTIONS Cloud.

Available CIM modules

Description	Fieldbus protocol	Product number
CIM 100	LONWorks	96824797
CIM 150	PROFIBUS DP	96824793
CIM 200	Modbus RTU	96824796
CIM 300	BACnet MS/TP	96893770
CIM 500	Ethernet	98301408
Antenna (puc)	3G/4G	99518079

For further information about data communication via CIM modules and fieldbus protocols, see the CIM documentation available in Grundfos Product Center at www.grundfos.com.

15. Variants

List of variants, on request

Below please find the range of options available for customizing the MTR, MTRE, SPK, MTH and MTA pumps to meet special requirements.

Contact Grundfos for further information or for requests other than the ones mentioned below.

Pumps

Variant	Applies to	Section
Immersion depth	MTR, MTRE	See the section on immersion depths, MTR, MTRE.
	SPK	See the section on immersion depths, SPK.
Horizontally mounted pump	MTR, MTRE SPK	See the section on horizontal mounting.
120 °C solution	MTR, MTRE SPK	See the section on 120 °C solution.
Inlet pipe	MTR, MTRE SPK MTH	See the section on inlet pipe.

Shaft seals

Variant	Applies to	Description
Shaft seal with FFKM, FXM or EDPM O-ring material	MTR, MTRE	We recommend shaft seals with FFKM, FXM or EPDM O-ring material for applications where the pumped liquid may damage the standard O-ring material.
	SPK	
	MTH	

Motors

Variant	Applies to	Description
ATEX motor	MTR	For operation in hazardous atmospheres, explosion-proof or dust-ignition-proof motors may be required.
Motor with anti-condensation heating unit	MTR SPK	For operation in humid environments motors with built-in anti-condensation heating unit may be required.
Motor with thermal protection	MTR SPK	Grundfos offers motors with built-in bimetallic thermal switches or temperature-controlled PTC sensors (thermistors) incorporated in the motor windings.
Oversize motor	MTR, MTRE SPK	Ambient temperatures above 40 °C or installation at altitudes of more than 1000 metres above sea level require the use of an oversize motor (derating).
Multiplug	MTR SPK MTH	Pumps with motors from 0.25 kW to 7.5 kW can be fitted with a 10-pin multiplug connection, type Han® 10 ES.
		The purpose of a multiplug connection is to make the electrical installation and the service of the pump easier. The multiplug functions as a plug-and-pump device.

Variant	Applies to	Description
4-pole motor	MTR	Grundfos offers 4-pole standard motors.
Advanced display	MTRE	The pumps can be fitted with HMI 301 operating panel as an option. The operating panel does not include a radio module.
Standard display	MTRE	The pumps can be fitted with HMI 201 operating panel as an option. The operating panel does not include a radio module.
Simple display	MTRE	The pumps can be fitted with HMI 100 or HMI 101 panel as an option. HMI 100 includes a radio module. HMI 101 does not include a radio module. Grundfos GO is required to configure and set the pump.

Certificates

Certificate	Description
Certificate of compliance with the order	According to EN 10204, 2.1. Grundfos document certifying that the pump supplied is in compliance with the order specifications.
Test certificate. Non-specific inspection and testing	According to EN 10204, 2.2. Certificate with inspection and test results of a non-specific pump.
Inspection certificate 3.1	Grundfos document certifying that the pump supplied is in compliance with the order specifications. Inspection and test results are mentioned in the certificate.
Inspection certificate	Grundfos document certifying that the pump supplied is in compliance with the order specifications. Inspection and test results are mentioned in the certificate. Certificate from the surveyor is included. Contact Grundfos if you require a certificate. We offer the following inspection certificates: <ul style="list-style-type: none"> • Lloyds Register of Shipping (LRS) • Det Norske Veritas (DNV) • Germanischer Lloyd (GL) • Bureau Veritas (BV) • American Bureau of Shipping (ABS) • Registro Italiano Navale Agenture (RINA) • China Classification Society (CCS) • Russian maritime register of Shipping (RS) • Biro Klassifikasio Indonesia (BKI) • United States Coast Guard (USCG) • Nippon Kaiji Koykai (NKK).
Standard test report	Certifies that the main components of the specific pump are manufactured by Grundfos, and that the pump has been QH-tested, inspected and conforms to the full requirements of the appropriate catalogues, drawings and specifications.
Material specification report	Certifies the material used for the main components of the specific pump.
Duty-point verification report	Certifies a test point specified by the customer. Issued according to ISO 9906 concerning "Duty point verification".
ATEX-approved pump (MTR)	Confirms that the specific pump is ATEX-approved according to the EU directive 94/9/EC, the "ATEX directive".

Note that other certificates are available on request.

Related information

[Immersion depths, MTR, MTRE](#)

[Immersion depths, SPK](#)

[Horizontal mounting](#)

[120 °C solution](#)

[Inlet pipe](#)

Immersion depths, MTR, MTRE

To meet specific depths of tanks and containers, the immersion depth of the pump can be varied using empty chambers. The number of impellers depends on the requested head, and can be found on the technical data pages for each product type.

Number of chambers	Immersion depth [mm]										
	MTR1s	MTR1	MTR3	MTR5	MTR 8	MTR10	MTR15	MTR20	MTR32	MTR45	MTR64
1	-	-	-	-	196	-	-	-	-	-	-
2	160	160	160	169	223	148	178	178	223	244	249
3	178	178	178	196	250	178	223	223	293	324	332
4	196	196	196	223	277	208	268	268	363	404	414
5	214	214	214	250	304	238	313	313	433	484	497
6	232	232	232	277	331	268	358	358	503	564	579
7	250	250	250	304	358	298	403	403	573	644	662
8	268	268	268	331	385	328	448	448	643	724	744
9	286	286	286	358	412	358	493	493	713	804	827
10	304	304	304	385	439	388	538	538	783	884	909
11	322	322	322	412	466	-	583	583	853	964	992
12	340	340	340	439	493	448	628	628	923	1044	1074
13	358	358	358	466	520	-	673	673	993	1124	1157
14	376	376	376	493	547	508	718	718	1063	1204	1239
15	394	394	394	520	574	-	763	763	1133	1284	1322
16	412	412	412	547	601	568	808	808	1203	1364	1404
17	430	430	430	574	628	-	853	853	1273	1444	1487
18	448	448	448	601	655	628	898	898	1343	-	-
19	466	466	466	628	682	-	943	943	-	-	-
20	484	484	484	655	709	688	988	988	-	-	-
21	502	502	502	682	736	-	1033	1033	-	-	-
22	520	520	520	709	763	748	-	-	-	-	-
23	538	538	538	736	790	778	-	-	-	-	-
24	556	556	556	763	817	808	-	-	-	-	-
25	574	574	574	790	844	838	-	-	-	-	-
26	592	592	592	817	871	868	-	-	-	-	-
27	610	610	610	844	898	898	-	-	-	-	-
28	628	628	628	871	925	928	-	-	-	-	-
29	646	646	646	898	952	958	-	-	-	-	-
30	664	664	664	925	979	988	-	-	-	-	-
31	682	682	682	952	1006	1018	-	-	-	-	-
32	700	700	700	979	-	-	-	-	-	-	-
33	718	718	718	1006	-	-	-	-	-	-	-
34	736	736	736	-	-	-	-	-	-	-	-
35	754	754	754	-	-	-	-	-	-	-	-
36	772	772	772	-	-	-	-	-	-	-	-
37	790	790	790	-	-	-	-	-	-	-	-
38	808	808	808	-	-	-	-	-	-	-	-
39	826	826	826	-	-	-	-	-	-	-	-
40	844	844	844	-	-	-	-	-	-	-	-
41	862	862	862	-	-	-	-	-	-	-	-

Number of chambers	Immersion depth [mm]										
	MTR1s	MTR1	MTR3	MTR5	MTR 8	MTR10	MTR15	MTR20	MTR32	MTR45	MTR64
42	880	880	880	-	-	-	-	-	-	-	-
43	898	898	898	-	-	-	-	-	-	-	-
44	916	916	916	-	-	-	-	-	-	-	-
45	934	934	934	-	-	-	-	-	-	-	-
46	952	952	952	-	-	-	-	-	-	-	-
47	970	970	970	-	-	-	-	-	-	-	-
48	988	988	988	-	-	-	-	-	-	-	-
49	1006	1006	1006	-	-	-	-	-	-	-	-

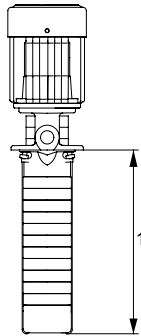

TM014460

Immersion depth (1)

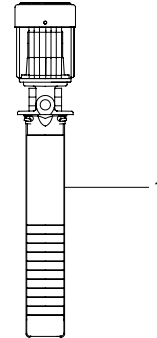

TM014214

Extension pipe (1)

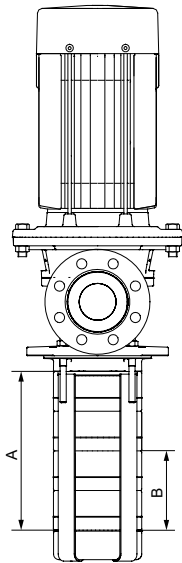

TM014991

Number of chambers (A) and impellers (B)

Immersion depths, SPK

To meet specific depths of tanks and containers, the immersion depth of the pump can be varied using empty chambers. The number of impellers depends on the requested head and can be found on the technical data pages for each product type.

Number of chambers	Immersion depth [mm]		
	SPK 1	SPK 2	SPK 4
1	140	140	140
2	-	-	-
3	182	182	182
4	-	-	-
5	224	224	224
6	-	-	-
7	266	266	266
8	287	287	287
9	-	-	-
10	-	-	-
11	350	350	350
12	-	-	-
13	392	392	392
14	-	-	-
15	434	434	434
16	455	455	455
17	476	476	476
18	-	-	-
19	518	518	518
20	-	-	-
21	560	560	560
22	-	-	-
23	602	602	602
24	-	-	-
25	644	644	644
26	-	-	-
27	-	-	-
28	-	-	-
29	-	-	-
30	-	-	-
31	770	770	770
32	-	-	-
33	-	-	-
34	-	-	-
35	-	-	-
36	-	-	-
37	896	896	896
19 + extension pipe	-	-	1005
23 + extension pipe	1005	1005	-

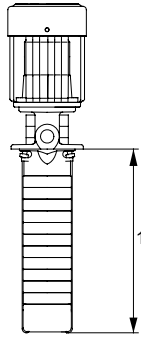

TM014460

Immersion depth (1)

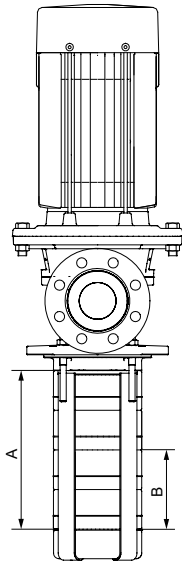

TM014991

Number of chambers (A) and impellers (B)

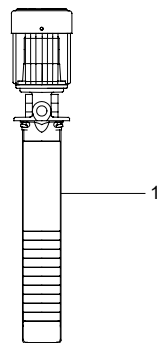

TM014214

Extension pipe (1)

Horizontal mounting

For safety or height reasons, certain applications, for instance on ships, require the pump to be mounted in horizontal position.

Pump version H for horizontal mounting is available for MTR, MTRE 1s, 1, 2, 3, 4, 5, 8, 10, 15 and 20.

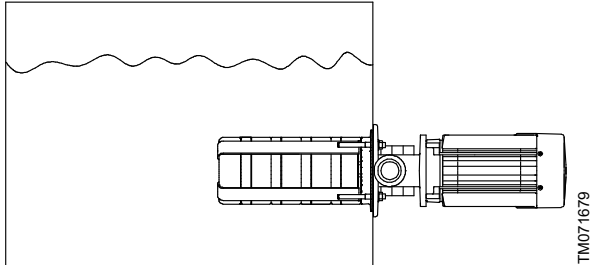

Horizontally installed MTR version H pump

On horizontally installed MTR, MTRE pumps, the drain hole in the pump head is fitted with a plug, and four closed nuts with O-rings are fitted to the straps. See fig. Version H pump head with closed nuts (1) and drain plug (2) in the section on 120 °C solution.

MTR, MTRE pumps for horizontal mounting are only available with stainless steel pump heads.

On horizontally installed MTR, MTRE pumps with motors from 5.5 kW and up, the motors have feet and must be supported.

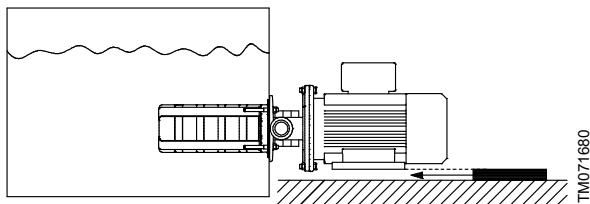

Horizontally installed MTR version H pump with foot support

120 °C solution

For applications with liquid temperature above 90 °C and up to 120 °C, Grundfos offers a solution for MTR, MTRE and SPK.

MTR, MTRE pumps for applications with liquid temperature above 90 °C and up to 120 °C are only available with stainless steel pump head.

Note that if the MTR, MTRE or SPK pump is to be used for applications with a liquid temperature above 90 °C and up to 120 °C, the drain hole in the pump head must be fitted with a plug, and four closed nuts with O-rings must be fitted to the straps.

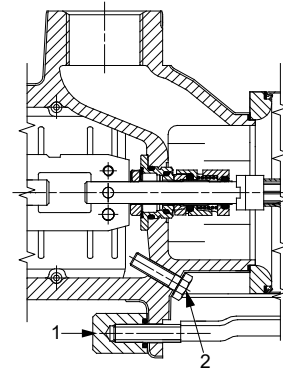

Version H pump head with closed nuts (1) and drain plug (2)

Inlet pipe

For compact coolant applications the filter is mounted inside the tank, and the pump sucks directly through this filter.

Pump	A [mm]	B [mm]	C [mm]	D [mm]
MTR, MTRE 1s, 1, 3, 5	48.5	15	∅64.8	∅60 x 3
MTR, MTRE 10, 15, 20	48	15	∅88.8	∅84 x 3
MTR, MTRE 32	48	15	∅104.8	∅100 x 3
MTR, MTRE 45	48	15	∅124.8	∅119.5 x 3
MTR, MTRE 64	48	15	∅133.7	∅128 x 3
SPK 1, 2, 4	48	15	∅56	∅51.2 x 3
MTH 2, 4	48	15	∅64.8	∅60 x 3

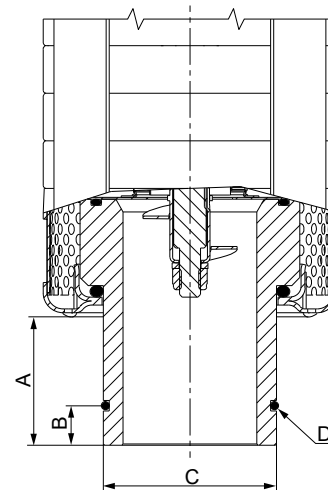

Inlet pipe

16. Grundfos Product Center

Online search and sizing tool to help you make the right choice.

From the international view, you can select your specific country to view the product range available to you.

International view: <https://product-selection.grundfos.com>

All the information you need in one place

Performance curves, technical specifications, pictures, dimensional drawings, motor curves, wiring diagrams, spare parts, service kits, 3D drawings, documents, system parts. The Product Center displays any recent and saved items - including complete projects - right on the main page.

Downloads

On the product pages, you can download installation and operating instructions, data booklets, service instructions, etc., in PDF format.

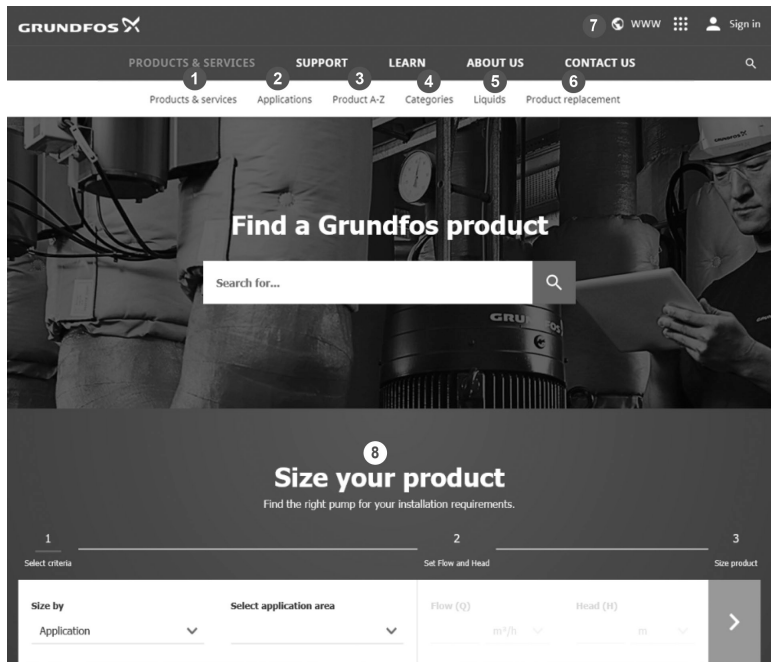

When you select your country, you will see the menus below. Note that some menus may not be available depending on the country.

Example: <https://product-selection.grundfos.com/uk>

Pos.	Description
1	Products & services enables you to find products and documents by typing a product number or name into the search field.
2	Applications enables you to choose an application to see how Grundfos can help you design and optimise your system.
3	Products A-Z enables you to look through a list of all the Grundfos products.
4	Categories enables you to look for a product category.
5	Liquids enables you to find pumps designed for aggressive, flammable or other special liquids.
6	Product replacement enables you to find a suitable replacement.
7	WWW enables you to select the country, which changes the language, the available product range and the structure of the website.
8	Sizing enables you to size a product based on your application and operating conditions.

96538374 07.2023
ECM: 1372873

GRUNDFOS Holding A/S
Poul Due Jensens Vej 7
DK-8850 Bjerringbro
Tel: +45 87 50 14 00
www.grundfos.com
<https://szivattyuk.hu>

GRUNDFOS 

Trademarks displayed in this material, including but not limited to Grundfos and the Grundfos logo, are registered trademarks owned by The Grundfos Group. © 2023 Grundfos Holding A/S, all rights reserved.