

6SR 6" submersible pumps



 Clean water
(Maximum sand content 100 g/m³)

 Civil use

 Agricultural use

※ **6SR submersible pumps: designed with special materials to resist sand abrasion for long-lasting performance**

PERFORMANCE RANGE

- Flow rate up to **1000 l/min** (60 m³/h)
- Head up to **390 m**

INSTALLATION AND USE

Designed to transfer clean water with sand content up to **100 g/m³**. Highly efficient and reliable, they are suitable for industrial, civil, and agricultural applications, such as water distribution coupled with pressure tanks, irrigation, pressure boosting, fire-fighting systems, and more.

INCLUDES

- ※ Three-phase electric motor 400 V - 50 Hz
The pump can be supplied with motor:
 - **6PD** rewindable and oil filled
 - **6PSR** rewindable and water filled
- ※ **4 m** power cable

APPLICATION LIMITS

- Liquid temperature up to **+35 °C**
- Maximum sand content **100 g/m³**
- Maximum operating depth below water level:
 - **200 m** with 6PD motors
 - **150 m** with 6PSR motors
- Operation:
 - in vertical position
 - horizontally with the following limits: up to **12 stages** or up to **11 kW**
- Starts per hour: **20** at regular intervals
- Minimum cooling flow **8 cm/s**
- Continuous running duty **S1**

AVAILABLE UPON REQUEST

- ※ 6SR-HYD pumps with double cable cover for coupling with 400/690 V Δ / \star dual voltage motors (star/delta)
- ※ Other voltages
- ※ Cooling jacket kit complete with filter and supinlets



CURVES AND PERFORMANCE DATA

50 Hz

6SR 12

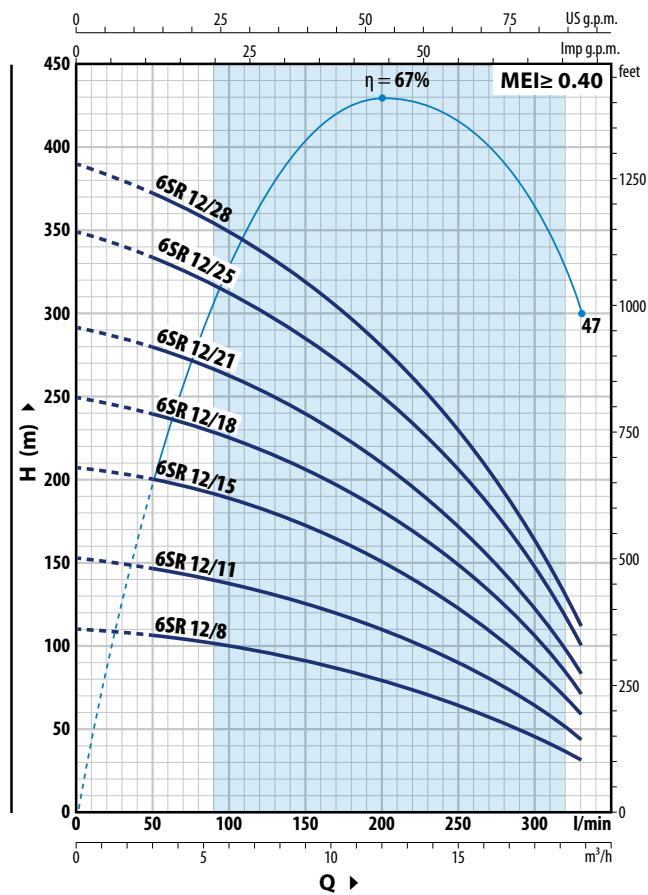

6SR 18

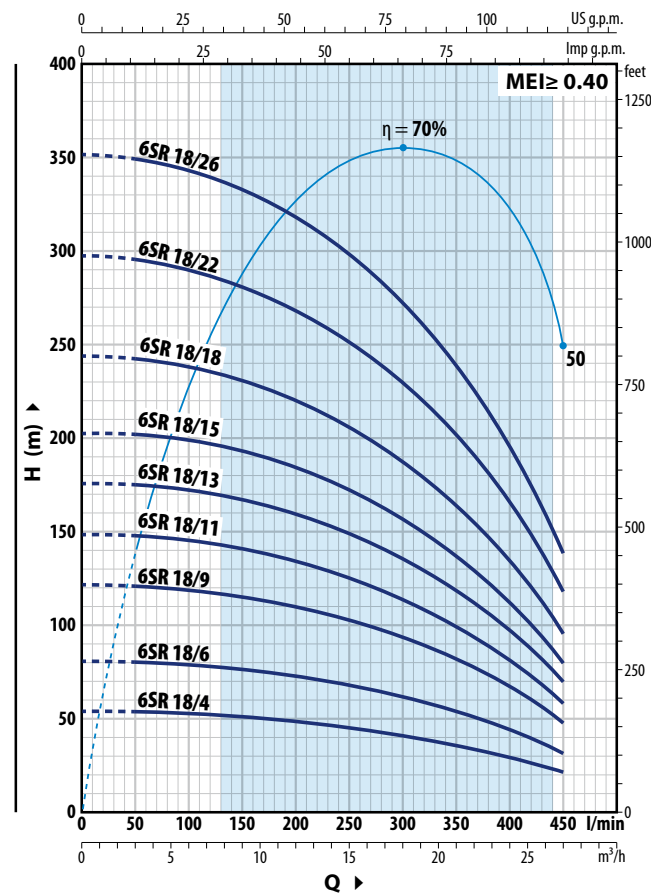

6SR 12

TYPE	POWER (P ₂)		Q	Flow rate (m ³ /h)													
	kW	HP		0	3.0	6.0	9.0	12.0	15.0	18.0	19.8						
Three-phase			l/min	0	50	100	150	200	250	300	330						
6SR 12/8	4	5.5	H metres		111	106	100	91	80	66	47	32					
6SR 12/11	5.5	7.5			153	146	138	125	110	91	65	44					
6SR 12/15	7.5	10			208	199	189	171	150	124	88	60					
6SR 12/18	9.2	12.5			250	239	225	205	180	149	106	72					
6SR 12/21	11	15			292	279	263	239	210	174	124	84					
6SR 12/25	13	17.5			349	331	313	285	250	206	147	100					
6SR 12/28	15	20			390	371	350	319	280	231	165	112					

6SR 18

TYPE	POWER (P ₂)		Q	Flow rate (m ³ /h)													
	kW	HP		0	3	6	9	12	15	18	21	24	27				
Three-phase			l/min	0	50	100	150	200	250	300	350	400	450				
6SR 18/4	4	5.5	H metres		54	53.8	53	51	49	46	42	37	30	22			
6SR 18/6	5.5	7.5			81	80.5	79	77	74	69	63	55	45	32			
6SR 18/9	7.5	10			122	121	119	116	111	103	94	83	68	48			
6SR 18/11	9.2	12.5			149	148	145.5	141	135	126	115	101	83	59			
6SR 18/13	11	15			176	175	172	167	160	149	136	120	98	70			
6SR 18/15	13	17.5			203	202	199	193	185	172	157	138	113	80			
6SR 18/18	15	20			244	242	238	231	221	206	188	165	135	96			
6SR 18/22	18.5	25			298	296	291	282	270	252	230	202	165	118			
6SR 18/26	22	30			352	350	344	334	320	298	272	239	195	139			

Q = Flow rate H = Total manometric head

Performance curves comply with EN ISO 9906 Grade 3B tolerance limits.

6SR 6" submersible pumps

CURVES AND PERFORMANCE DATA

50 Hz

6SR 27

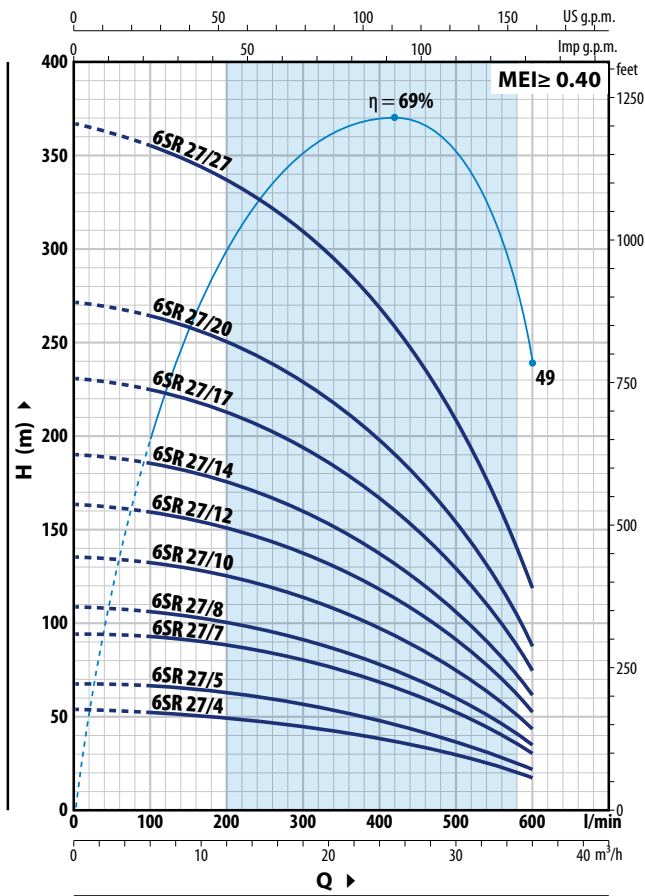

6SR 36

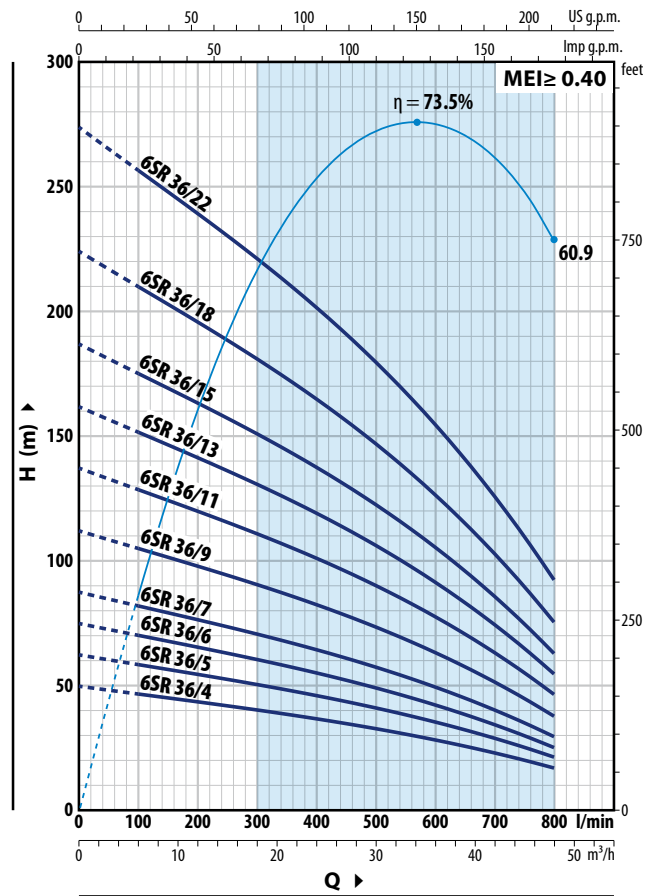

6SR 27

TYPE	POWER (P ₂)		Q	Flow rate (m³/h)									
	kW	HP		0	6	12	18	24	30	36			
Three-phase			l/min	0	100	200	300	400	500	600			
6SR 27/4	4	5.5	H metres	54	53	49	45	40	30	18			
6SR 27/5	5.5	7.5		68	66	62	57	50	37	22			
6SR 27/7	7.5	10		95	92	87	80	70	52	31			
6SR 27/8	9.2	12.5		109	106	99	91	80	59	35			
6SR 27/10	11	15		136	132	124	114	100	74	44			
6SR 27/12	13	17.5		164	159	149	137	120	89	53			
6SR 27/14	15	20		191	185	174	160	140	104	62			
6SR 27/17	18.5	25		231	224	211	194	170	126	75			
6SR 27/20	22	30		272	264	248	228	200	148	88			
6SR 27/27	30	40		367	356	335	308	270	205	119			

6SR 36

TYPE	POWER (P ₂)		Q	Flow rate (m³/h)									
	kW	HP		0	6	12	18	24	30	36	42	48	
Three-phase			l/min	0	100	200	300	400	500	600	700	800	
6SR 36/4	4	5.5	H metres	50	46.5	43.5	40	36.5	32.5	28	23	17	
6SR 36/5	5.5	7.5		62.5	58.5	54.5	50.5	46	41	35	28.5	21	
6SR 36/6	5.5	7.5		75	70	65.5	60.5	55	49	42	34.5	25	
6SR 36/7	7.5	10		87	82	76	70	64	57	49	40	29.5	
6SR 36/9	9.2	12.5		112	105	98	91	83	74	63.5	51.5	37.5	
6SR 36/11	11	15		137	128	120	111	101	90	77	63	46	
6SR 36/13	13	17.5		162	152	142	131	119	106	91	74.5	54.5	
6SR 36/15	15	20		187	175	163	151	138	123	105	86	63	
6SR 36/18	18.5	25		224	210	196	181	165	147	127	103	75	
6SR 36/22	22	30		274	257	239	221	202	180	155	126	92	

Q = Flow rate H = Total manometric head

Performance curves comply with EN ISO 9906 Grade 3B tolerance limits.

CURVES AND PERFORMANCE DATA

50 Hz

6SR 44

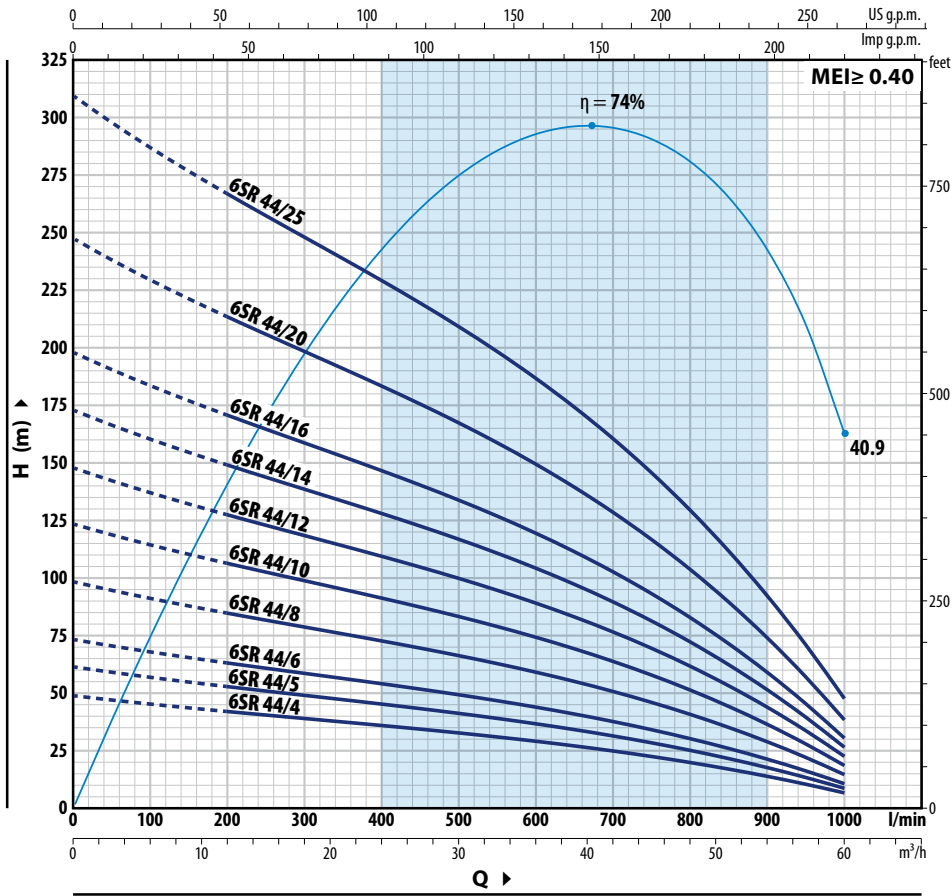

6SR 44

TYPE Three-phase	POWER (P ₂)		Q	Flow Rate (Q)											
	kW	HP		0	12	18	24	30	36	42	48	54	60		
			0	200	300	400	500	600	700	800	900	1000			
6SR 44/4	4	5.5	H metres	49.5	43	40	37	33.5	30	25.8	21	15	8		
6SR 44/5	5.5	7.5		62	53.5	49.5	46	42	37.5	32.5	26	18.7	10		
6SR 44/6	7.5	10		74	64	59.5	55	50.5	45	38.5	31.5	22.4	11.5		
6SR 44/8	9.2	12.5		99	86	80	74	67	60	51.5	41.5	30	15.5		
6SR 44/10	11	15		124	107	99	92	84	75	64.5	52	37.5	19.5		
6SR 44/12	13	17.5		149	128	119	110	101	90	77	62.5	45	23.5		
6SR 44/14	15	20		174	150	139	129	118	105	90	73	52.5	27.5		
6SR 44/16	18.5	25		198	171	159	147	134	120	103	83	59.5	31		
6SR 44/20	22	30		248	214	199	184	168	150	129	104	75	39		
6SR 44/25	30	40		310	267	249	230	210	188	161	130	93	49		

Q = Flow rate H = Total manometric head

Performance curves comply with EN ISO 9906 Grade 3B tolerance limits.

6SR 6" submersible pumps

EXAMPLES OF INSTALLATION

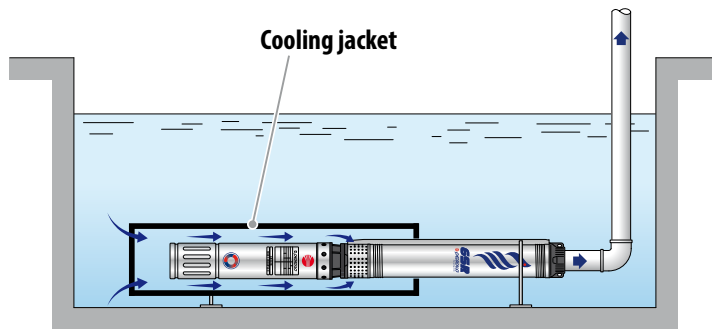

COOLING JACKET

✘ When the pump is installed in reservoirs, rivers, or lakes, it requires an external cooling jacket (flow generator) to ensure sufficient water flow across the motor surface, preventing overheating.



✘ The **6SR** pumps are suitable for wells with a minimum diameter of **6" (153 mm)**.

✘ The submersible pump must be lowered into the well through the delivery pipe to a depth that ensures it remains fully submerged, maintaining at least 50 cm or one metre from the bottom of the well, even if liquid levels decrease during operation.

✘ It is advisable to secure the submersible pump using a stainless-steel cable connected to appropriate attachments on the delivery port.

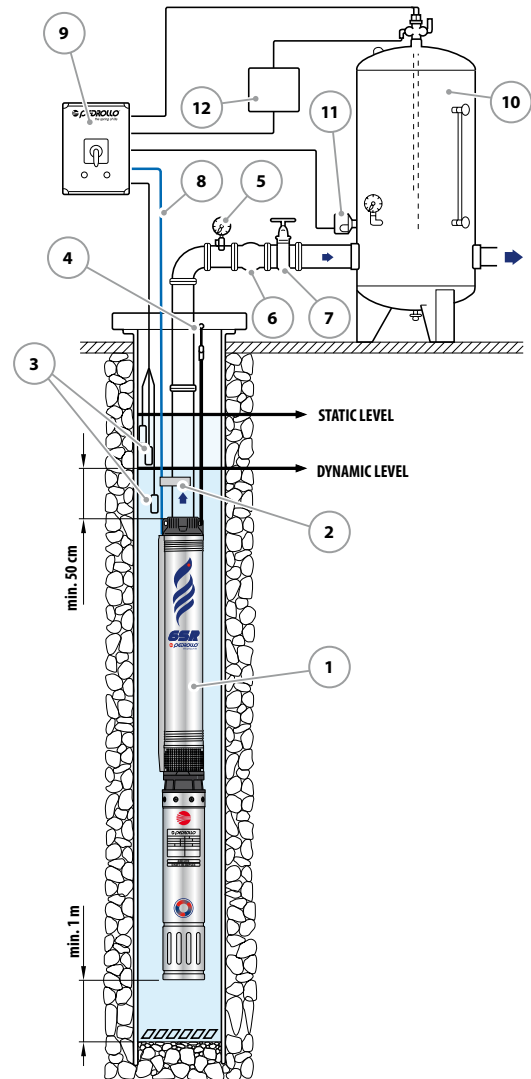

COMPONENTS

- 1) Submersible pump
- 2) Fixing Ties
- 3) Level control probes
- 4) Bracket and anchor cable
- 5) Pressure Gauge
- 6) Check valve
- 7) Flow control gate valve
- 8) Electrical power supply cable
- 9) Control panel
- 10) Autoclave tank
- 11) Pressure switch
- 12) Solenoid valve/electric compressor

MATERIALS AND COMPONENTS

1 Delivery port	Cast iron with cataphoresis treatment with thread according to ISO 228/1
2 Check valve	Stainless steel AISI 304 stainless steel
3 Motor bracket	Cast iron with cataphoresis treatment sized to NEMA standards
4 External sleeve	AISI 304 stainless steel
5 Impellers	Noryl™ and coated with special sand-resistant elastomer
6 Diffusers	Noryl™
7 Diffuser boxes	AISI 304 stainless steel
8 Pump shaft	AISI 304 stainless steel
9 Pump bearings	Made of AISI 316L stainless steel coated with chromium oxide to resist sand
10 Tow coupling	AISI 420 stainless steel
11 Filter	AISI 304 stainless steel
12 Cable sheath	AISI 304 stainless steel
13 Motor 6"	※ 6PD = rewindable oil filled motor ※ 6PSR = rewindable in water filled motor

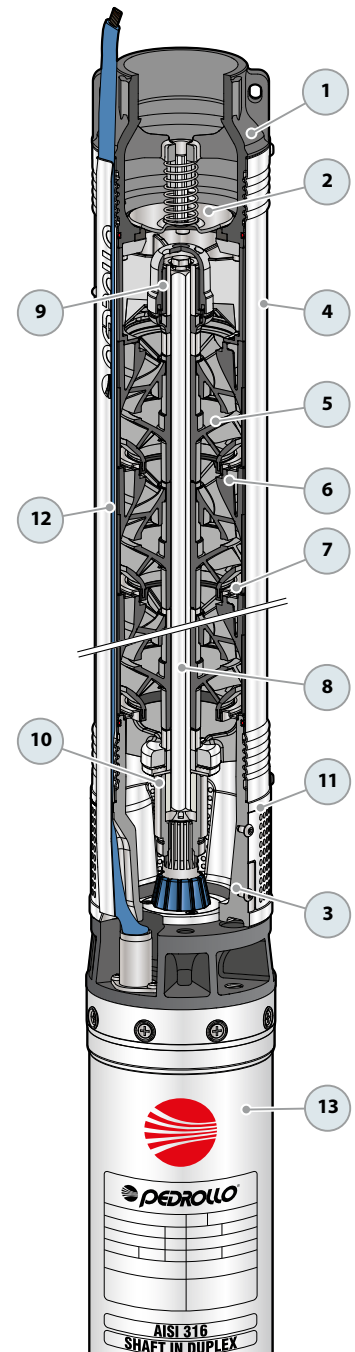

6SR 6" submersible pumps

DIMENSIONS AND WEIGHT

TYPE	DN	DIMENSIONS mm			kg	TYPE	DN	DIMENSIONS mm			kg
		h1	h2	h3				h1	h2	h3	
Three-phase ※						Three-phase ※					
6SR 12/8 - PD	3"	714	595	1309	55.0	6SR 12/8 - PSR	3"	714	620	1334	71.6
6SR 12/11 - PD		845	625	1470	58.3	6SR 12/11 - PSR		845	620	1465	73.9
6SR 12/15 - PD		1063	660	1723	67.8	6SR 12/15 - PSR		1063	670	1733	84.7
6SR 12/18 - PD		1193	700	1893	74.6	6SR 12/18 - PSR		1193	700	1893	91.0
6SR 12/21 - PD		1324	765	2089	83.6	6SR 12/21 - PSR		1324	750	2074	100.3
6SR 12/25 - PD		1497	820	2317	92.4	6SR 12/25 - PSR		1497	780	2277	106.4
6SR 12/28 - PD		1627	820	2447	94.8	6SR 12/28 - PSR		1627	840	2467	115.2
6SR 18/4 - PD		541	595	1136	50.5	6SR 18/4 - PSR		541	620	1161	67.1
6SR 18/6 - PD		628	625	1253	53.0	6SR 18/6 - PSR		628	620	1248	68.6
6SR 18/9 - PD		758	660	1418	60.4	6SR 18/9 - PSR		758	670	1428	77.3
6SR 18/11 - PD		845	700	1545	66.5	6SR 18/11 - PSR		845	700	1545	82.9
6SR 18/13 - PD		976	765	1741	76.4	6SR 18/13 - PSR		976	750	1726	93.1
6SR 18/15 - PD		1063	820	1883	83.6	6SR 18/15 - PSR		1063	780	1843	97.6
6SR 18/18 - PD		1193	820	2013	85.9	6SR 18/18 - PSR		1193	840	2033	106.3
6SR 18/22 - PD		1367	883	2250	98.8	6SR 18/22 - PSR		1367	890	2257	116.4
6SR 18/26 - PD		1541	953	2494	109.1	6SR 18/26 - PSR		1541	975	2516	130.5
6SR 27/4 - PD		579	595	1174	51.0	6SR 27/4 - PSR		579	620	1199	67.6
6SR 27/5 - PD		632	625	1257	52.9	6SR 27/5 - PSR		632	620	1252	68.5
6SR 27/7 - PD		738	660	1398	59.8	6SR 27/7 - PSR		738	670	1408	76.7
6SR 27/8 - PD		790	700	1490	65.2	6SR 27/8 - PSR		790	700	1490	81.6
6SR 27/10 - PD	896	765	1661	72.6	6SR 27/10 - PSR	896	750	1646	89.3		
6SR 27/12 - PD	1047	820	1867	82.8	6SR 27/12 - PSR	1047	780	1827	96.8		
6SR 27/14 - PD	1153	820	1973	84.5	6SR 27/14 - PSR	1153	840	1993	104.9		
6SR 27/17 - PD	1311	883	2194	97.0	6SR 27/17 - PSR	1311	890	2201	114.6		
6SR 27/20 - PD	1470	953	2423	106.9	6SR 27/20 - PSR	1470	975	2445	127.3		
6SR 27/27 - PD	1840	1098	2938	130.1	6SR 27/27 - PSR	1840	1215	3055	165.9		

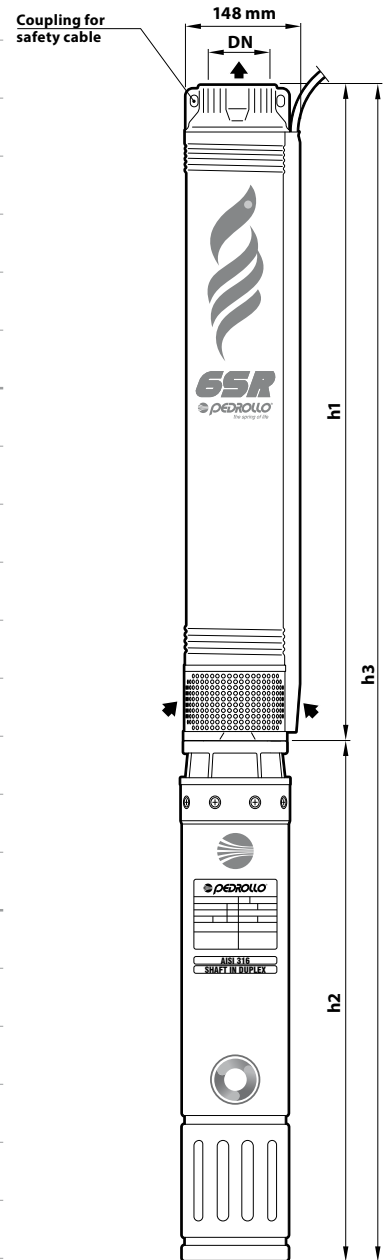

※ 6PD = rewindable oil filled motor

※ 6PSR = rewindable water filled motor

DIMENSIONS AND WEIGHT

TYPE Three-phase ※	DN	DIMENSIONS mm			kg	TYPE Three-phase ※	DN	DIMENSIONS mm			kg		
		h1	h2	h3				h1	h2	h3			
6SR 36/4 - PD	3"	761	595	1356	54.9	6SR 36/4 - PSR	3"	761	620	1381	71.5		
6SR 36/5 - PD		859	625	1484	57.6	6SR 36/5 - PSR		859	620	1479	73.2		
6SR 36/6 - PD		958	625	1583	59.1	6SR 36/6 - PSR		958	620	1578	74.7		
6SR 36/7 - PD		1056	660	1716	66.3	6SR 36/7 - PSR		1056	670	1726	83.2		
6SR 36/9 - PD		1253	700	1953	73.9	6SR 36/9 - PSR		1253	700	1953	90.3		
6SR 36/11 - PD		1450	765	2215	83.8	6SR 36/11 - PSR		1450	750	2200	100.5		
6SR 36/13 - PD		1646	820	2466	92.5	6SR 36/13 - PSR		1646	780	2426	106.5		
6SR 36/15 - PD		1843	820	2663	96.7	6SR 36/15 - PSR		1843	840	2683	117.1		
6SR 36/18 - PD		2138	883	3021	109.1	6SR 36/18 - PSR		2138	890	3028	126.7		
6SR 36/22 - PD		2532	953	3485	123.5	6SR 36/22 - PSR		2532	975	3507	143.9		
6SR 44/04 - PD		3"	761	595	1356	54.9		6SR 44/04 - PSR	3"	761	620	1381	71.5
6SR 44/05 - PD			859	625	1484	57.6		6SR 44/05 - PSR		859	620	1479	73.2
6SR 44/06 - PD			958	660	1618	62.8		6SR 44/06 - PSR		958	670	1628	79.7
6SR 44/08 - PD			1154	700	1854	72.4		6SR 44/08 - PSR		1154	700	1854	88.8
6SR 44/10 - PD	1351		765	2116	82.1	6SR 44/10 - PSR	1351	750		2101	98.8		
6SR 44/12 - PD	1548		820	2368	91.0	6SR 44/12 - PSR	1548	780		2328	105.0		
6SR 44/14 - PD	1745		820	2565	95.1	6SR 44/14 - PSR	1745	840		2585	115.5		
6SR 44/16 - PD	1942		883	2825	107.0	6SR 44/16 - PSR	1942	890		2832	124.6		
6SR 44/20 - PD	2335		953	3288	119.5	6SR 44/20 - PSR	2335	975		3310	139.9		
6SR 44/25 - PD	2827		1098	3925	144.2	6SR 44/25 - PSR	2827	1215		4042	175.2		

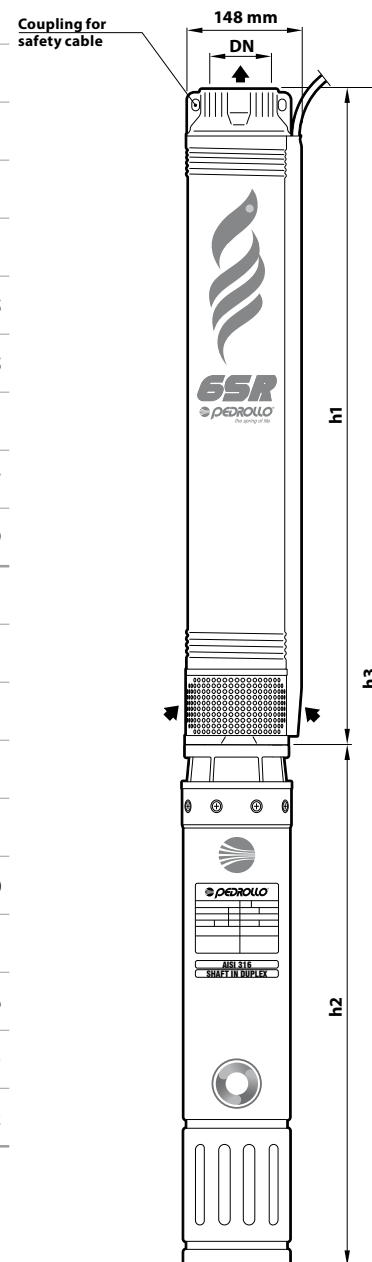

※ 6PD = rewindable oil filled motor

※ 6PSR = rewindable water filled motor